

The background of the entire page is a repeating pattern of the Armani Casa logo. The logo consists of a stylized, wavy, organic shape filled with a dense, fine-lined texture. The color is a muted, earthy olive green. The pattern is set against a light cream or off-white background.

ARMANI / CASA

GENERAL CATALOGUE 2022 / 2023

ARMANI / CASA

INDEX

LIMITED EDITIONS	8	LIGHTING	190
UPHOLSTERY	18	FLOOR LAMPS	
SOFAS		TABLE LAMPS	
MODULAR SYSTEMS		LANTERNS	
ARMCHAIRS AND COMPOSITIONS		WALL LIGHTS	
CHAISE-LONGUES AND DAYBEDS		RUGS & MATS	226
OTTOMANS		WALLCOVERINGS	250
CHAIRS	56	PRECIOUS FIBERS 1	
CHAIRS WITH ARMRESTS		PRECIOUS FIBERS 2	
CHAIRS WITHOUT ARMRESTS		PRECIOUS FIBERS 3	
DIRECTOR'S CHAIRS		REFINED STRUCTURES 1	
TUB CHAIRS		REFINED STRUCTURES 2	
TALL STOOLS		GRAPHIC ELEMENTS 1	
TABLES	76	GRAPHIC ELEMENTS 2	
DINING TABLES		FABRICS	298
CONSOLES		FURNITURE FINISHING	360
SMALL AND COFFEE TABLES		WOODS	
BEDSIDE TABLES		STONES	
BEDS	126	METALS	
DESKS	144	SHELLS AND NATURE-INSPIRED FINISHES	
CABINETS AND BOOKCASES	154	STRAW AND INTERTWINED PATTERNS	
BAR CABINETS		DECORATIONS AND LACQUERS	
BOOKCASES		LEATHERS	
CHESTS OF DRAWERS		TECHNICAL MATERIALS	
MULTIFUNCTIONAL CABINETS		ACCESSORIES	382
OCCASIONAL	178	DECORATIVE ACCESSORIES	
COIFFEUSES		GIFTS	
RACKS		TABLEWARE	
MIRRORS		TEXTILES	
SCREENS		ALPHABETICAL INDEX	414

THE BRAND

Inseparably linked to all the other Armani brands, Armani/Casa provides a platform for Giorgio Armani to set out his vision of the interiors: intimate special places with a mood of emotional pleasure, somewhere to relax and entertain guests surrounded by beauty and elegance. The purpose of the Armani/Casa research is to communicate an atmosphere, to dress everyday living spaces in the same way Armani fashion creations dress people.

The home imagined by Giorgio Armani is a place that provides the pleasure of well-being. Armani/Casa modernizes the way spaces are used by completely removing anything superfluous, redundant and useless. Nothing is left to chance, and every detail is meticulously conceived to express the idea of subtle luxury.

The Armani/Casa aesthetic philosophy focuses on simple lines and perfect proportions, enriched by precious materials, refined finishes, and elegant textiles. The quest for sophisticated comfort turns into the creation of a total home setting, which uses a modern and rational design language. Inspirations from Art Déco and Eastern cultures blend with contemporary influences, in a constant dialogue with the world of fashion.

Today Armani/Casa offers a complete range of products for home furnishing: from furniture to accessories, from fabrics to wallcoverings, from kitchen systems to bathroom concepts.

1982	The Logo lamp is first introduced within the Giorgio Armani office located in via Durini, Milan: it is the first product ever designed by Giorgio Armani for the home.
2000	The first Armani/Casa flagship store opens in Via Manzoni 31, Milan.
2001	New Armani/Casa stores open in Paris, New York and Los Angeles.
2004	The Interior Design Studio by Armani/Casa is born due to increasing demand to create made to measure design projects for private clients.
2008	Molteni and Armani/Casa create a new partnership for future production and distribution of kitchen systems with the brand Armani/Dada.
2009	Armani Casa Exclusive Textiles by Rubelli is established, a partnership between Armani/Casa and Rubelli for the production and distribution of furnishing fabrics.
2010	Armani/Roca is established, a partnership between Armani/Casa and Roca for the production and commercialisation of a new bathroom concept.
2010	The first Armani Hotel opens in Dubai within the Burj Khalifa, the tallest building in the world.
2011	The second Armani Hotel opens in Milan, just a few steps from the renowned La Scala theatre and the historical district of Brera.
2014	Armani/Casa Exclusive Wallcoverings Collection is launched, a partnership between Armani/Casa and Jannelli&Volpi for the creation of an extraordinary range of wall coverings.
2015	The Justin desk, a limited edition designed to celebrate the 40th anniversary of the Giorgio Armani brand, is developed.
2015	<i>The Art of Living by Giorgio Armani</i> exhibition, a retrospective of Armani/Casa Interior Design Studio's most important global projects, is presented in Milan.
2016	Armani/Casa acquires the strategic location in Corso Venezia 14 in Milan, in between the Fashion and the Design district of the city.
2016	<i>The Art of Living by Giorgio Armani</i> exhibition is presented in Beijing.
2017	A new Logo lamp is especially created in a limited edition version to celebrate its 35th anniversary.
2020	Armani/Casa is selected to be part of the <i>Quirinale Contemporaneo</i> project, to enrich the institutional palace of the Presidency of the Italian Republic in Rome.
Today	Armani/Casa has a sales network operating worldwide, with stores located in the world's major cities, including: Milan, Paris, London, New York, Los Angeles, Miami, Tokyo, Shanghai, and Beijing.

SALONE DEL MOBILE 2022

“In recent years, I have focused on the essential aspects of my style lexicon. In design, as in fashion, I feel the need to reaffirm the founding elements that define the Armani style. This exhibition, devised to mark the return of the Salone del Mobile in attendance, is a way of traversing my aesthetics in its salient aspects, highlighting connections, suggestions, and references. For the first time I am using the spaces of the Silos to create an exhibition that offers an immersive and emotional experience in the Armani/Casa world”
Giorgio Armani.

Introduced by a projection of Logo Lamps and concluded by a behind-the-scenes gallery, the special installation traced a clear path through the inspirations, themes and recurring references of the designer.

JAPAN

The balance of finishes, textures, and treatments refers in an abstract way to traditional elements of Japan and its domestic architecture, evoked in the picture characterised by treated linen panels, crossed by a geometric pattern of lacquered red lines.

LIQUID SILK

Fabric, a connective element between fashion and furnishings, is the focus of the picture defined by notes of teal and the fluid movement of silk. The versatility of this material is reflected in the idea of comfort in an intimate setting.

DÉCO

Sophisticated materials and special finishes are a recurring feature of Armani/Casa: precious linear touches reminiscent of *Art Déco* in the shapes, in the use of wood, marble, quartz and shells. In this picture, tactile sensations become space, defined by mother-of-pearl mosaic tiles.

SAILING BOAT

The balance between local tradition and distant cultures, and the dialogue between past and present, are also recalled in the picture dedicated to the sailing boat. The scene is built around these binomials: traditional finishes are enriched by the juxtaposition to modern and innovative materials.

BAMBOO

A bamboo thicket in macro-scale recalls the world of nature, whose textures and palettes are an unfailing source of inspiration for the Armani universe. The striped pattern defined by bamboo immediately recalls the three-dimensional surface of the *canneté*, iconic fabric in Armani fashion since the very beginning.

CHINA

The extreme rarefaction of Oriental aesthetics is evoked with an abstract taste in the space devoted to China: there is a powerful contrast between red, the colour of joy and good fortune, and the space cancelled out by black.

TIGERS

Nature, travel and the discovery of exoticism are represented by the painting dedicated to the tiger, the feline that dominates the current year in the Chinese zodiac. Never literal, Giorgio Armani has chosen to evoke its coat, with almost surreal taste.

WATER

Water, a symbol of life and regeneration, which flows in a variety of forms in the Armani world. In this picture, everything is calm and peaceful: a liquid, submerged environment welcomes and mixes natural references and 1930s and 1940s elegance, captured in the rugged texture of shagreen.



LIMITED EDITIONS



LOGO Table lamp/BOCCHERINI Small table

CLUB
BLACK STRAW MARQUETRY

Cocktail cabinet in limited edition, 100 pieces. The design of Club takes inspiration from vintage travel furniture featuring x-shaped legs. Outer lining in Technical Shagreen Fabric, doors in Black Straw Marquetry with legs and other details in Satin Natural Brass; interior in metallized grey lacquer. The Club cocktail cabinet features container doors for the storage of glasses. The interior holds a lower pull-out shelf covered by an extralight transparent tempered glass (5 mm thick) for the preparation of drinks, a fold-out top for service and three lacquered drawers: one for cocktail utensils, one to store the ice bucket and the last for bottles. MADE IN ITALY.

DIMENSIONS
79x60x130h cm - Inch 31.1x23.6x51.2h

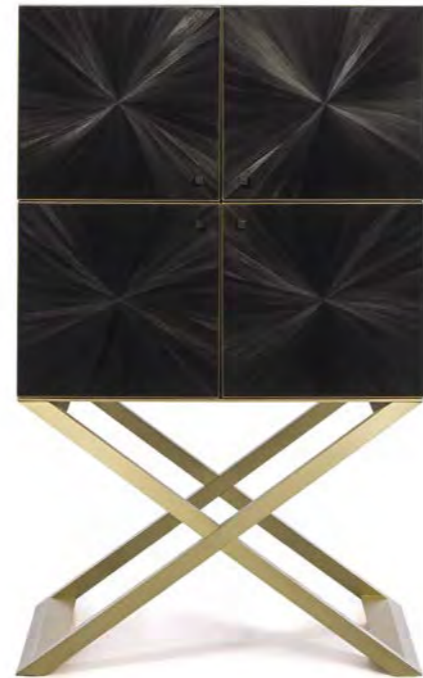
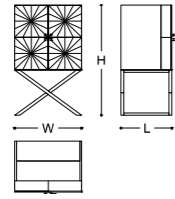

CODE 048075 CA885 C0020

FINISHES

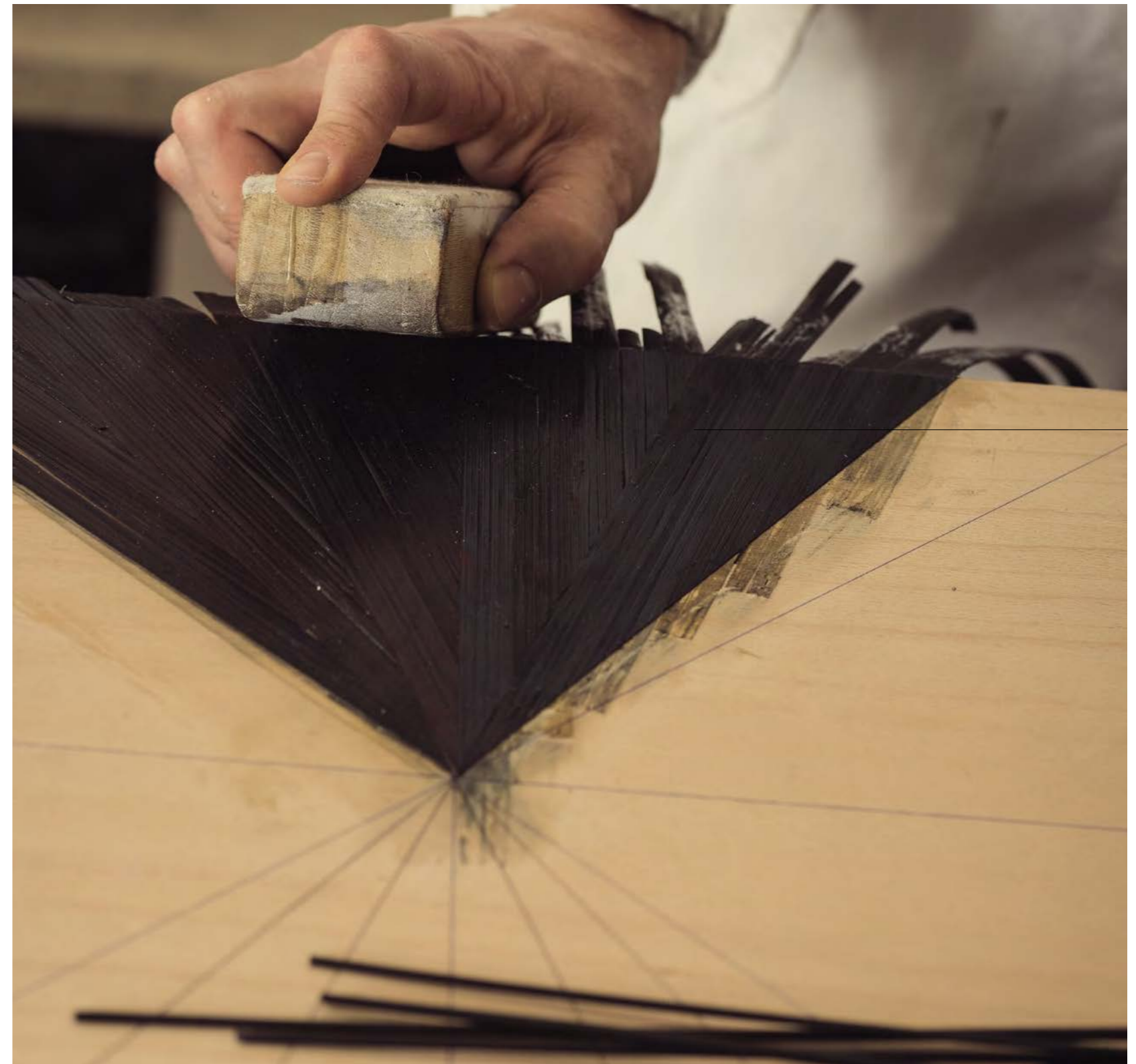



ROYAL

Bar cabinet in limited edition, 88 pieces. Royal is a hand-crafted cabinet marked by details reminding a revisited secrétaire with shutter closure. The structure is marked by an elongated cylindrical shape with semicircular sides, which become also the base of the furniture. The bar unit is closed by two flexible doors that slide horizontally into the main structure, unveiling the working area completed by shelves and a large drawer for preparation tools. Always keeping a strong connection to Oriental influences and fashion inspirations, the cabinet is clad in a special weaving of paper and cotton reminiscent of a Japanese tatami and textured fabrics typical in Giorgio Armani's aesthetics. Inside, back-lit panels of gold-toned methacrylate add movement thanks to their particular motif, recalling marble veins and mother of pearl. Metal details are in light brass with a satin finish. MADE IN ITALY.

DIMENSIONS
150x60x160h cm - Inch 59x23.6x62.9h

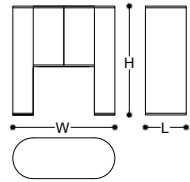

CODE: 050604 CH181 C0053

FINISHES

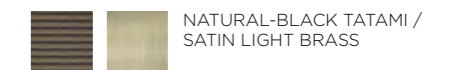

ANTOINETTE

Coiffeuse in limited edition, 100 pieces. This iconic vanity table is characterized by the cylindrical shape with folding top and hidden seat. The grey leather covered with transparent lacquer takes almost a green hue, which creates a beautiful contrast with the inner drawer in acrylic inspired by natural mother-of-pearl. The seat is upholstered with dark green velvet. MADE IN ITALY.

DIMENSIONS
CLOSED: Ø 70x89,5h cm - Inch Ø 27.5x35.2h

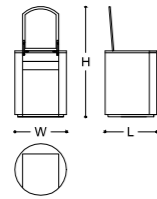

CODE: 045609 CA800 C0185

FINISHES

LACQUERED GREY SHAGREEN EFFECT LEATHER / DARK GREEN LACQUER

ROSANNA

Rosanna is an armchair marked by a strong Art Déco influence. Coming directly from a piece within Giorgio Armani's private collection, this armchair with curved shapes stands out for the spiraling motif on the legs in solid wood and the upholstery in velvet featuring a leopard design. Rosanna is a limited edition of only 38 pieces. Matching cushions can be bought separately. MADE IN ITALY.

DIMENSIONS
80x90x74h cm - Inch 31.4x35.4x29.1h

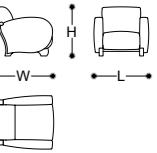

CODE: 050656 CH210 C4753

FINISHES

CANALETTO WALNUT

LOGO

Logo is the undiscussed icon of Armani/Casa. Designed in 1982 for the office located in via Durini in Milan, it is the very first furnishing product ever conceived by Giorgio Armani himself. To celebrate the 35th anniversary of this iconic lamp, the 2017 collection introduced a revamped limited edition of only 200 signed pieces. The squared wooden structure of the lamp features a thin layer of metal as base, like the prismatic joint of the stem. The switch is located on the base, in the shape of Giorgio Armani's signature in brass. Lampshade in methacrylate coupled with copper mesh; diffuser below the lampshade. Every lamp comes with a numbered small book that counts also as certificate of authenticity. MADE IN ITALY.

DIMENSIONS
48x48x80h cm - Inch 18.8x18.8x31.4h

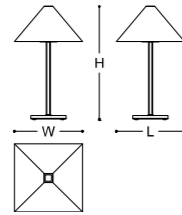

CODE: 049342 UP004 C9553

FINISHES



UPHOLSTERY

SOFAS
MODULAR SYSTEMS
ARMCHAIRS AND COMPOSITIONS
CHAISE-LONGUES AND DAYBEDS
OTTOMANS



CANALETTO

Canaletto is a classic sofa with essential lines. It features two width options for what concerns both the armrests (22 or 30 cm) and the seats (80 or 90 cm). It can be upholstered with all Armani/Casa fabrics and Soft Touch Leathers in collection. Fabric covers are removable. The Canaletto range includes also an armchair, a footrest and a modular system.

MADE IN ITALY.

DIMENSIONS

SEAT OPTIONS:

REGULAR:

80x105x78h cm - Inch 31.5x41.3x30.7h

LARGE:

90x105x78h cm - Inch 35.4x41.3x30.7h

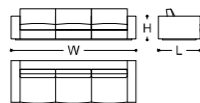

ARMREST OPTIONS:

REGULAR: 22x105x60h cm - Inch 8.6x41.3x23.6h

LARGE: 30x105x60h cm - Inch 11.8x41.3x23.6h

2 SEATS ARMREST 22 cm - Inch 8.7:

204x105x60h cm - Inch 80.3x41.3x23.6h

2 SEATS LARGE - ARMREST 22 cm - Inch 8.7:

224x105x60h cm - Inch 88.2x41.3x23.6h

2 SEATS ARMREST 30 cm - Inch 11.8:

220x105x60h cm - Inch 86.6x41.3x23.6h

2 SEATS LARGE - ARMREST 30 cm - Inch 11.8:

240x105x60h cm - Inch 94.5x41.3x23.6h

3 SEATS ARMREST 22 cm - Inch 8.7:

284x105x60h cm - Inch 111.8x41.3x23.6h

3 SEATS LARGE - ARMREST 22 cm - Inch 8.7:

314x105x60h cm - Inch 123.6x41.3x23.6h

3 SEATS ARMREST 30 cm - Inch 11.8:

300x105x60h cm - Inch 118.1x41.3x23.6h

3 SEATS LARGE - ARMREST 30 cm - Inch 11.8:

330x105x60h cm - Inch 130x41.3x23.6h

SH: 42 cm - Inch 16.5



CODE: 048116 CT00C TX180 (3 SEATS 90 CM, ARMRESTS 22 CM), STOCKHOLM FABRIC

LONDON

Two or three-seat sofa with visible feet in Brushed Brown Oak. Base structure in wood and multy-density polyurethane foam, goose down cushions. Upholstery available in all suitable Armani/Casa fabrics or Soft Touch Leathers in collection. Fabric covers are fully removable. The London range includes also an armchair and a footrest.

MADE IN ITALY.

DIMENSIONS

2-SEATS:

202x95x81h cm - Inch 79.5x37.4x31.9h

3-SEATS:

240x95x81h cm - Inch 94.5x37.4x31.9h

SH: 44 cm - Inch 17.3

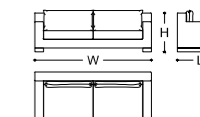

FINISHES

BRUSHED BROWN OAK



CODE: 045029 RMA0B TR815 (2 SEATS), LUXEMBOURG FABRIC

OSIMO

The Osimo sofa stands out for its particular shape, featuring a high seatback that ends with imposing armrests to create a sort of alcove. All details are rounded. Due to its design, Osimo is a perfect stand-alone piece that can be placed together with different products, either matching the same curved volumes or contrasting with sharper lines. Upholstery available in all suitable Armani/Casa fabrics or Soft Touch Leathers in collection. MADE IN ITALY.

DIMENSIONS

2 SEATS:
230x100x83h cm - Inch 90.5x39.3x32.6h

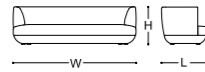

3 SEATS:
270x100x83h cm - Inch 106.2x39.3x32.6h



SH: 44 cm - Inch 17.3



CODE: 050202 CT00C TX129 (3 SEATS), PALERMO FABRIC

RAPHAEL

Two or three-seat sofa whose distinctive feature is the wooden frame around the armrests. Raphael has a high cushion in polyurethane foam that makes the seating particularly comfortable. Upholstery available in all suitable Armani/Casa fabrics and Soft Touch Leathers in collection. Covers are not removable. The range includes also an armchair. Raphael can be selected also without wooden details on the armrests. MADE IN ITALY.

DIMENSIONS

2 SEATS:
180x95x62h cm - Inch 70.9x37.4x24.4h

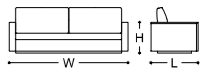

3 SEATS:
240x95x62h cm - Inch 94.5x37.4x24.4h



SH: 40 cm - Inch 15.7

FINISHES



BLACK MAPLE *



BRUSHED BROWN OAK



BROWN MAHOGANY



* CODE: 048388 ACE0C TX126, PALERMO FABRIC

REMBRANDT

Rembrandt is a two seats sofa characterized by contrasting shapes: it features rounded backrest and armrests completed by two long rectangular cushions, conceived to increase comfort in the lower back while seating. Visible feet in solid wood. Upholstery available in all Armani/Casa fabrics and Soft Touch Leathers in collection. Fabric covers are removable. MADE IN ITALY.

DIMENSIONS
2 SEATS:
224x98x88h cm - Inch 88.2x38.6x34.6h

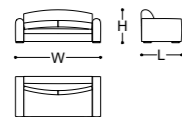

SH: 42 cm - Inch 16.5

FINISHES

BRUSHED BLACK ASHWOOD



CODE: 050649 CT00C TX127, PALERMO FABRIC

RENOIR

Renoir is an upholstered sofa with rounded shape and solid wood feet (10 cm high). The concepts of extreme coziness and relax are the main inspirations of this piece, marked by curved volumes and the unique seating cushion. Renoir can be placed at the center of the room, where it can become the focal point of the setting especially if matched with other rounded armchairs and footrests. Available in all fabrics and Soft Touch Leathers in collection. Covers are not removable. MADE IN ITALY.

DIMENSIONS
2 SEATS:
240x93x84h cm - Inch 94.4x36.6x33.1h



SH: 42 cm - Inch 16.5

FINISHES

BRUSHED BLACK ASHWOOD



CODE: 050581 CT00C ER065, SAO PAULO FABRIC

ROBINSON

Robinson reinterprets the iconic lines of Otello, one of the most sculptural sofas by Armani/Casa. The high armrests have the same height of the seatback, giving this piece an elegant and outstanding look. The range includes also an armchair. Padding in goose feathers, with inner structure in rubber; base in solid ashwood (feet are 6 cm high). Available in all fabrics and Soft Touch Leathers in collection; fabric covers are removable. MADE IN ITALY.

DIMENSIONS

2 SEATS:
240x105x80h cm - Inch 94.5x41.3x31.5h

4 SEATS:
270x105x80h cm - Inch 106.3x41.3x31.5h

ARMCHAIR:
103x98x80h cm - Inch 40.5x38.6x31.5h

SH: 44 cm - Inch 17.3

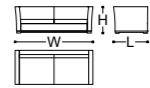

FINISHES

BRUSHED BLACK ASHWOOD



CODE: 050583 CT00C TX129 (4 SEATS), PALERMO FABRIC



CANALETTO

In addition to the armchair, the footrest, the two and the three-seat sofa, the Canaletto range offers also a modular system. The system includes different elements that can be variously combined: a corner element, a one-seat element, a two-seat element (with or without left/right armrest) and a chaise-longue (with or without left/right armrest). To ensure versatility and meet the taste of clients, the seat comes in two different sizes of 80 cm and 90 cm. In addition, two armrest widths are available (22 cm and 30 cm). Upholstery available in all suitable Armani/Casa fabrics or Soft Touch Leathers in collection. MADE IN ITALY.

DIMENSIONS

SINGLE SEAT:

80x105x78h cm - Inch 31.4x41.3x30.7h
 90x105x78h cm - Inch 35.4x41.3x30.7h

CHAISE LONGUE:

90x195x78h cm - Inch 35.4x76.7x30.7h

SINGLE ARMREST:

22x105x57h cm - Inch 8.6x41.3x22.4h
 30x105x57h cm - Inch 11.2x41.3x22.4h

CORNER ELEMENT:

105x105x78h cm - Inch 41.3x41.3x22.4h

FOOTREST:

105x105x42h cm - Inch 41.3x41.3x16.5h

SH: 42 cm - Inch 16.5



CODE: 048019 CT00C TR319 / 048031 CT00C TR319 / 048030 CT00C TR319 / 048037 CT00C TR319 (SEATS 80 CM, CHAISE-LONGUE 90 CM, ARMREST 22 CM), DORCHESTER FABRIC

Composition Units

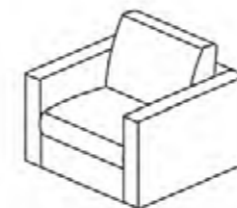

ARMCHAIR

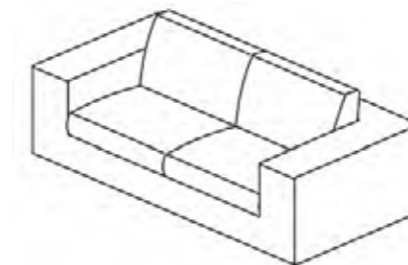

2 SEATS SOFA

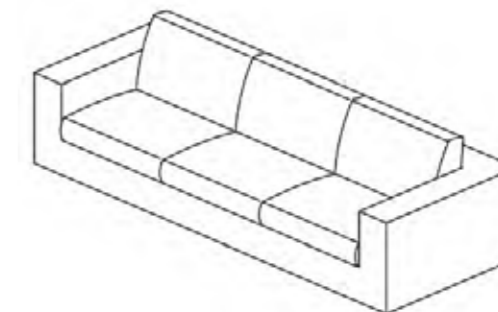

3 SEATS SOFA



2 SEATS ELEMENT + LEFT ARMREST

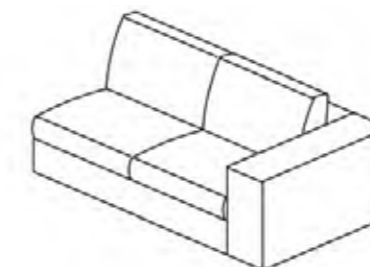

2 SEATS ELEMENT + RIGHT ARMREST

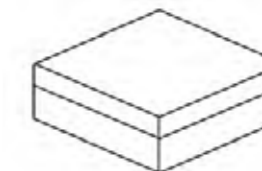

FOOTREST

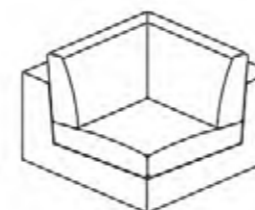

CORNER ELEMENT



SINGLE ELEMENT



2 SEATS ELEMENT



CHAISE LONGUE NO ARMREST

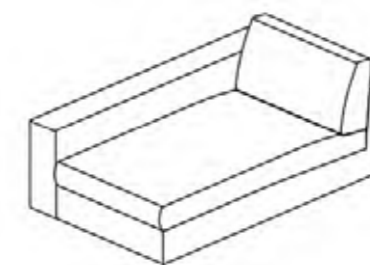

CHAISE LONGUE + LEFT ARMREST



CHAISE LONGUE + RIGHT ARMREST

ENGADIN

In addition to the daybed, the Engadin range offers also a modular system. The Engadin range is available only with armrests and seat cushions of one width, 25 cm and 80 cm respectively. All elements can be combined in a variety of ways to satisfy all needs. The structure of the seats is slightly tilted and includes springs and a steel frame. The seats cushions are filled with feathers and have a central foam rubber element, while the backrest cushions are filled only with feathers for greater comfort. The distinctive feature of Engadin is the iconic radial shape of the armrest, which runs along the entire outer edge of the sofa becoming its backrest. The sofa can be entirely upholstered with all suitable Armani/Casa fabrics or Soft Touch Leathers in collection. MADE IN ITALY.

DIMENSIONS

ARMREST:

25x105x78h cm - Inch 9.8x41.3x30.7h

1/2/3 SEATS ELEMENT:

80x105x91h cm - Inch 31.5x41.3x35.8h

160x105x91h cm - Inch 63x41.3x35.8h

240x105x91h cm - Inch 94.5x41.3x35.8h

2 SEATS ELEMENT WITH LEFT OR RIGHT ARMREST:

186x105x91h cm - Inch 72.8x41.3x35.8h

2 SEATS SOFA:

210x105x91h cm - Inch 82.6x41.3x35.8h

3 SEATS SOFA:

290x105x91h cm - Inch 114.1x41.3x35.8h

CHAISE LONGUE:

80x195x91h cm - Inch 31.5x76.7x35.8h

With armrest: 105x195x91h cm - Inch 41.3x76.7x35.8h

CORNER ELEMENT:

105x105x91h cm - Inch 41.3x41.3x35.8h

SH: 44 cm - Inch 13.3



CODE: 048282 CT00C TR498 / 048286 CT00C TR498 / 048281 CT00C TR498, ENGLAND FABRIC

Composition Units

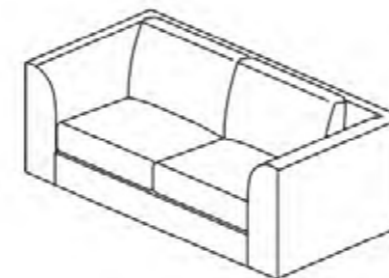

2 SEATS SOFA

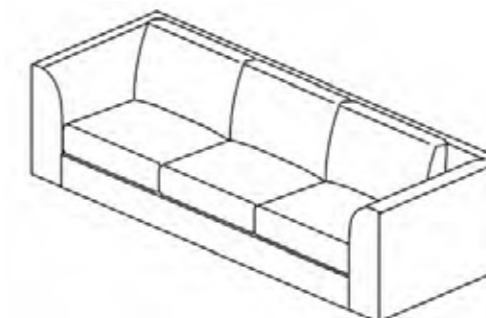

3 SEATS SOFA



2 SEATS ELEMENT + LEFT ARMREST



2 SEATS ELEMENT + RIGHT ARMREST

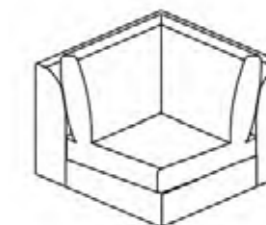

CORNER ELEMENT



SINGLE ELEMENT



2 SEATS ELEMENT



3 SEATS ELEMENT



CHAISE LONGUE NO ARMREST



CHAISE LONGUE + LEFT ARMREST

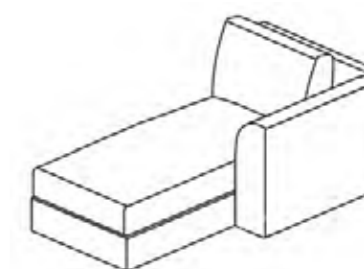

CHAISE LONGUE + RIGHT ARMREST

OPEN

Open recalls the neat aesthetics typical of Armani/Casa. Conceived to be classic yet contemporary pieces, all modules – corner, footrest and keystone element excluded – of this sofa are available also with a sliding seat to become even more comfortable. A monolithic recessed base lifts the seat from the ground. Since all modules host one seat only, Open can be customized in many different ways to create linear, angular and curved compositions, suitable for any living room. The keystone sectional element is available in a unique size with an angle of 45°. The two end-modules (left and right, 80/90/100 cm seat) are available also with an equipped armrest, conceived to store books/magazines/newspapers, remote controls and other objects; the inner structure of this drawer is in wood. This range can be upholstered with all fabrics and Soft Touch Leathers in collection; fabric covers are removable. MADE IN ITALY.

DIMENSIONS
SINGLE ELEMENT (WITH OR WITHOUT SLIDING SEAT)

SEAT 80 CM: 80x110x75h cm - Inch 31.5x43.3x29.5h
 SEAT 90 CM: 90x110x75h cm - Inch 35.4x43.3x29.5h
 SEAT 100 CM: 100x110x75h cm - Inch 39.3x43.3x29.5h

LEFT / RIGHT ELEMENT (WITH OR WITHOUT SLIDING SEAT)

SEAT 80 CM: 110x110x75h cm - Inch 43.3x43.3x29.5h
 SEAT 90 CM: 120x110x75h cm - Inch 47.2x43.3x29.5h
 SEAT 100 CM: 130x110x75h cm - Inch 51.1x43.3x29.5h

FOOTREST:

SEAT 80 CM: 80x110x42h cm - Inch 31.5x43.3x16.5h
 SEAT 90 CM: 90x110x42h cm - Inch 35.4x43.3x16.5h
 SEAT 100 CM: 100x110x42h cm - Inch 39.3x43.3x16.5h

CORNER ELEMENT:
 110x110x75h cm - Inch 43.3x43.3x29.5h

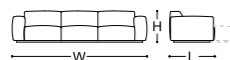

KEystone SECTIONAL ELEMENT:
 140x110x75h cm - Inch 55.1x43.3x29.5h



SH: 43 cm - Inch 17

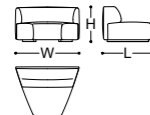

CODE: 050185 CTOOD TX172 / 050181 CTOOD TX172 / 050183 CTOOD TX172, SURABAYA FABRIC (SEAT 90 CM)

Examples of possible compositions

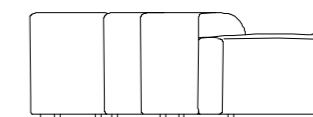
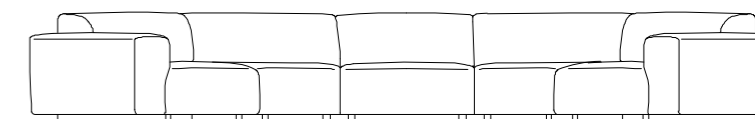
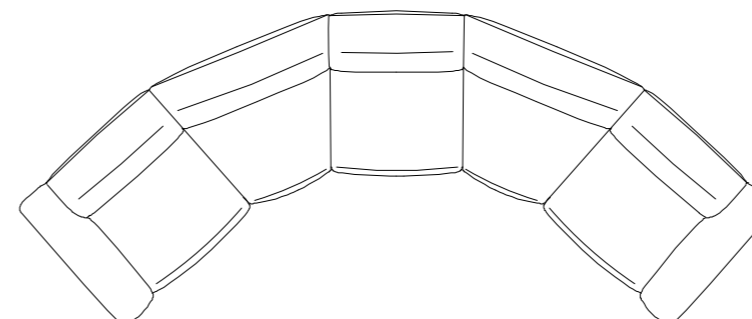
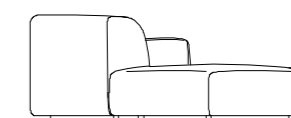
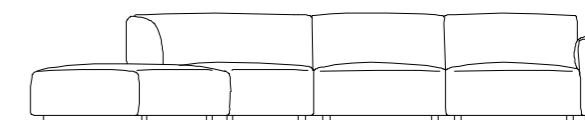
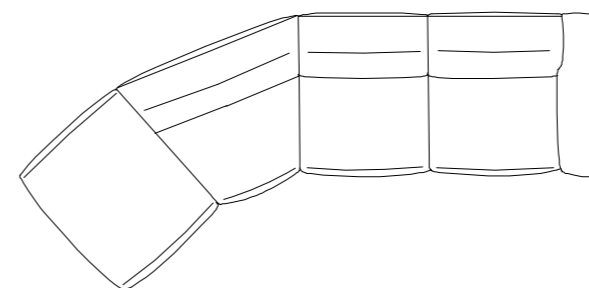
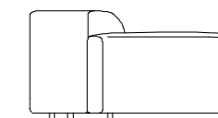
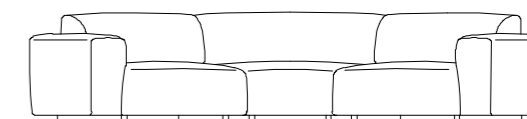
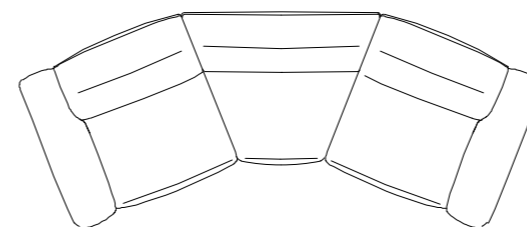

ORSON

Orson offers a wide variety of options, since it includes different freestanding pieces as well as a complete modular system. All elements are marked by sinuous lines. Upholstery available in all suitable fabrics or Soft Touch Leathers in collection. Covers in fabric are removable.
MADE IN ITALY.

DIMENSIONS

2 SEATS:
190x105x80h cm - Inch 74.8x41.3x31.4h

2 SEATS LARGE:
230x105x80h cm - Inch 90.5x41.3x31.4h

3 SEATS:
270x105x80h cm - Inch 106.2x41.3x31.4h

RIGHT/LEFT 2 SEATS ELEMENT:
175x110x80h cm - Inch 68.8x41.3x31.4h

RIGHT/LEFT 3 SEATS ELEMENT:
255x110x80h cm - Inch 100.4x41.3x31.4h

RIGHT/LEFT CHAISE-LONGUE:
105x255x80h cm - Inch 41.3x100.3x31.4h

SH: 44 cm - Inch 17.3

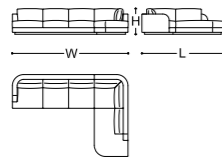

CODE: 050166 CT00C TX099 / 050167 CT00C TX099, OSLO FABRIC

Composition Units



2 SEATS SOFA



2 SEATS LARGE SOFA

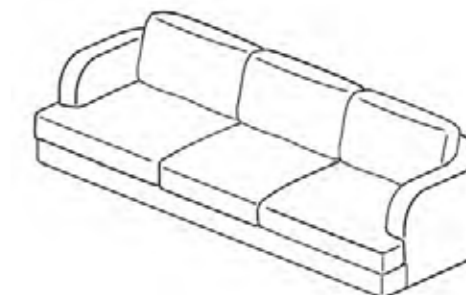

3 SEATS SOFA



2 SEATS ELEMENT + LEFT ARMREST



2 SEATS ELEMENT + RIGHT ARMREST



3 SEATS ELEMENT + LEFT ARMREST

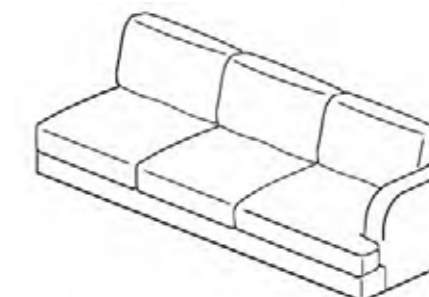

3 SEATS ELEMENT + RIGHT ARMREST

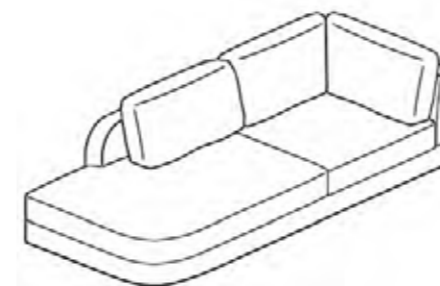

CHAISE LONGUE + LEFT ARMREST

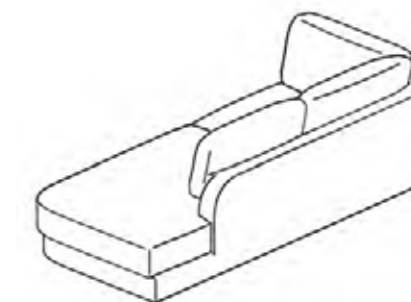

CHAISE LONGUE + RIGHT ARMREST

BALOON

Tubular armchair and footrest. These iconic pieces draw inspiration from the style of the 30s. The visible metal structure is in Satin Black Nickel. Upholstery is not removable and available in the bi-elastic fabric Oulu only. Baloon can easily become the focal point of a room thanks to its attractive design and vintage touch. MADE IN ITALY.

DIMENSIONS
ARMCHAIR:
 87x92x67h cm - Inch 34.3x36.2x26.3h
 SH: 40 cm - Inch 15.7

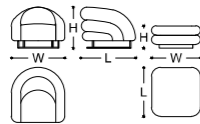

FOOTREST:
 80x80x36,5h cm - Inch 31.5x31.5x14.4h



CODE: 045938 CT00C TX105 (ARMCHAIR), 048117 CT00C TX105 (FOOTREST), OULU FABRIC

FINISHES

 SATIN BLACK NICKEL

BARBICAN

Small right or left corner armchair with footrest. The two armchairs can be placed one close to the other to create a small sofa; in the same way, armchair and footrest can be used to create a real chaise-longue. Covers are not removable and are available in all suitable Armani/Casa fabrics or Soft Touch Leathers in collection. MADE IN ITALY.

DIMENSIONS
ARMCHAIR:
 80x80x80h cm - Inch 31.5x31.5x31.5h
 SH: 42 cm - Inch 16.5

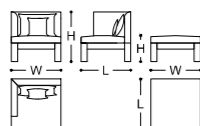

FOOTREST:
 80x80x42h cm - Inch 31.5x31.5x16.5h



* CODE: 045950 NOCOD TR848 (ARMCHAIR LEFT ARMREST), 048130 NOCOD TR848 (FOOTREST), LILLE FABRIC

FINISHES

 BROWN MAHOGANY

 CANALETTO WALNUT *

 BRUSHED BROWN OAK

CANALETTO

The Canaletto range includes also an armchair and a large footrest, both with removable covers (when in fabric). Upholstery available in all suitable Armani/Casa fabrics or Soft Touch Leathers in collection. MADE IN ITALY.

DIMENSIONS
ARMCHAIR:
 95x90x80h cm - 37.4x35.4x31.5h
 SH: 42 cm - Inch 16.5

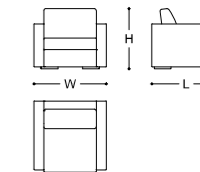

FOOTREST:
 105x105x42h cm - Inch 41.3x41.3x16.54h



CODE: 048093 CT00x TR723 (ARMCHAIR), FABRIC TO CHOOSE

ESSEX

Armchair with enveloping shape, thanks to the curved armrests in multidensity foam. Available in two sizes. Visible wooden feet. Essex can be upholstered with all suitable Armani/Casa fabrics or Soft Touch Leathers in collections. Fabric covers are removable. MADE IN ITALY.

DIMENSIONS
REGULAR:
 82x87x67h cm - Inch 32.3x33.9x26.4h

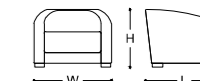

LARGE:
 90x90x67h cm - Inch 35.4x35.4x26.4h



SH: 39 cm - Inch 15.3



CODE: 045492 RMA0E TX175 (LARGE), SUVA FABRIC

FINISHES

 BRUSHED BROWN OAK

JULIE

Julie is a resting armchair that stands out for its elegant curved design, inspired by a petal of a lotus flower, and its metal base. On the side view, Julie shows a distinctive curved and raised edge, giving the impression that the armchair is lifted from the floor. The structure is realized in foam and can be upholstered with Thin or Soft Touch Leathers, as well as all suitable Armani/Casa fabrics. MADE IN ITALY.

DIMENSIONS
73x83x79h cm - Inch 28.7x32.7x31.1h

SH: 44 cm - Inch 17.3

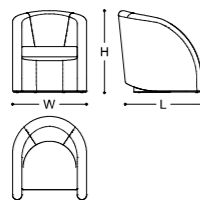

CODE: 050023 CA900 C0054, THIN LEATHER

FINISHES

SATIN LIGHT BRASS



LONDON

Classic armchair and footrest that complete the London range. Visible wooden feet. Upholstery available in all suitable Armani/Casa fabrics or Soft Touch Leathers in collection. Fabric covers are removable. MADE IN ITALY.

DIMENSIONS
ARMCHAIR:
101x95x80h cm - Inch 39.8x37.4x31.5h
SH: 44 cm - Inch 17.3

FOOTREST:
101x120x44h cm - Inch 39.8x47.2x17.3h

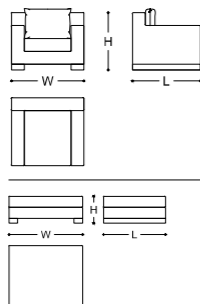

CODE: 045031 RMA0x, FABRIC TO CHOOSE

FINISHES

BRUSHED BROWN OAK



MARGOT

Margot is a relaxing armchair with footrest, inspired by the design of the range Lea. The structure is in solid wood with four rounded feet. Differently from the Lea chair, Margot has no decorative zip. Margot introduces a material exclusively available on the Margot range: the top quality Red Soft Leather. The upholstery is not removable and can be selected in the bi-elastic fabric Oulu, as well as two kinds of leathers in collection (Soft Touch, Thin). Padding in foam rubber, inner structure in steel. MADE IN ITALY.

DIMENSIONS
ARMCHAIR:
82x98x83h cm - Inch 32.3x38.6x32.7h
SH: 47 cm - Inch 18.5

FOOTREST:
62x62x43h cm - Inch 24.4x24.4x16.9h

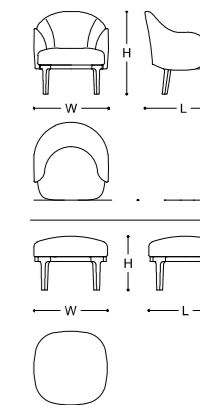

CODE: 049310 CA900 C0554 (ARMCHAIR), 049311 CA900 C0554 (FOOTREST), THIN LEATHER

FINISHES

CANALETTO WALNUT



PASCAL

The Pascal armchair is marked by its curved design, where the armrests are created by the prosecution of the seatback itself. The enveloping shape is not imposing at all, making this armchair ideal for small spaces/corners and for the contract sector as well. Another feature of this piece is the presence of four feet in solid wood. The inner structure of the seat features springs in harmonic steel, while the seatback presents a rubber padding. Due to its curved lines, Pascal can be subject to limitations when choosing the upholstery: the upholstery is hence available in all Armani/Casa fabrics suitable for this kind of shape, plus all Soft Touch Leathers in collection. This armchair is available in a special Brown Vintage Leather developed for this range only. Covers are not removable. MADE IN ITALY.

DIMENSIONS
80x83x70h cm - Inch 31.5x32.6x27.5h

SH: 40 cm - Inch 15.7

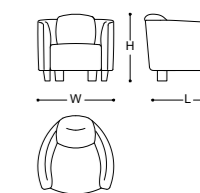

CODE: 050349 CH053 C0053, BROWN VINTAGE LEATHER

FINISHES

CANALETTO WALNUT



PAUL

The Paul armchair takes inspiration from seats typical of the 30s and the 40s, immediately recalling the aesthetics of gents' clubs of that time. Armani/Casa modernizes this classic design by adding updated details, like a higher seat and revised proportions. A distinctive feature of this piece is the presence of visible vertical stitchings on the seatback, which create almost a *matelassé* effect reminiscent of collectors' cars of the early XX century. Inner structure of seat and seatback with springs in harmonic steel; four thin squared feet in solid wood. Upholstery available in all Armani/Casa fabrics and Soft Touch Leathers in collection, plus a special Beige Vintage Leather developed exclusively for this range. Covers are not removable. MADE IN ITALY.

DIMENSIONS
98x96x77h cm - Inch 38.5x37.7x30.3h

SH: 42,5 cm - Inch 16.7

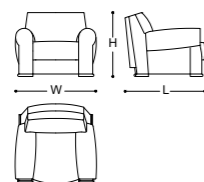

FINISHES

 CANALETTO WALNUT



CODE: 050353 CH039 C3055, BEIGE VINTAGE LEATHER

RAPHAEL

Armchair that completes the Raphael range. Raphael has a high cushion in polyurethane foam that makes the seating particularly soft and ergonomic. Upholstery available in all suitable Armani/Casa fabrics and soft touch leathers in collection. Covers are not removable. The range includes also an armchair. Raphael can be selected also without wooden details on the armrests. MADE IN ITALY.

DIMENSIONS
95x95x62h cm - Inch 37.4x37.4x24.4h

SH: 40 cm - Inch 15.7

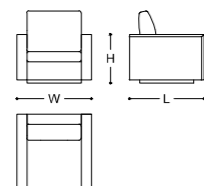

FINISHES

 BLACK MAPLE *

 BRUSHED BROWN OAK

 BROWN MAHOGANY



* CODE: 048388 ACE0C TX126, PALERMO FABRIC

RONDÒ

Rondò is an armchair characterized by an enveloping shape, thanks to its curved design. The backrest creates a single element with the rounded armrests. On the back view, the armchair shows a peculiar - almost spherical - silhouette. Given these unique features, Rondò can easily become the focal point of a room. The slightly recessed base, on which the armchair can rotate, is made in lacquer. The upholstery is not removable and is available in Soft Touch Leather or in bi-elastic fabric Oulu only. MADE IN ITALY.

DIMENSIONS
86x80x78h cm - Inch 33.8x31.5x30.7h

SH: 40 cm - Inch 15.7

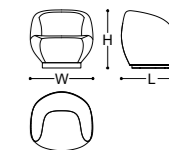

FINISHES

 PLATINUM LACQUER



CODE: 050650 CT00C TX105, OULU FABRIC

TOKYO

Armchair with structure in wood and in multi-density polyurethane foam. Feet in solid brown oak. It can be upholstered with all suitable Armani/Casa fabrics or Soft Touch Leathers in collection. Fully removable fabric covers. MADE IN ITALY.

DIMENSIONS
84x93x62h cm - Inch 33.1x36.6x24.4h

SH: 45 cm - Inch 17.7

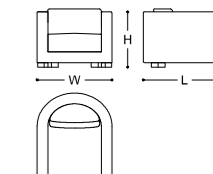

FINISHES

 BRUSHED BROWN OAK



CODE: 045088 RMA0C TX135, PANAMA FABRIC



SHARON

Sharon is an armchair with footrest, sharing the same concept of the Morfeo bed and the Onda chaise-longue: the inspiration comes from the idea of a folded paper sheet, creating a sinuous silhouette in a single piece. The seat and the seatback of the armchair cushion are padded and upholstered in Siracusa in Platinum colour: a fabric showing a materic effect created by a mix of different yarns (viscose, cotton, polyester, linen) playing around the same palette. The borders of the structure are in solid Canaletto Walnut. The footrest can also be used as a coffee table. MADE IN ITALY.

DIMENSIONS

ARMCHAIR:
90x82x77h cm - Inch 35.4x32.2x30.3h

SH: 45 cm - Inch 17.7

FOOTREST:
60x45x47h cm - Inch 23.6x17.7x18.5h

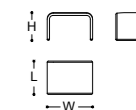
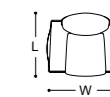

* CODE: 050711 CH965 ER048 (ARMCHAIR), 050767 CH965 C0554 (FOOTREST)

FINISHES



CANALETTO WALNUT /
SIRACUSA FABRIC (ER048 - PLATINUM) /
DOVE GREY LEATHER (CUOIO)

BORROMINI

Chaise-longue in Shiny Santos Rosewood that can be upholstered with all suitable Armani/Casa fabrics in collection. The curved lines are inspired by lounge furniture dating back to the early 20th century. With its eclectic look, Borromini is perfect to be used in a studio or in a relax area; it will create the perfect atmosphere in a sunroom, close to a fireplace or a bookcase. Covers are not removable.
MADE IN ITALY.

DIMENSIONS
198x78x86,2h cm - Inch 78x30.7x33.9h

SH: 40,7 cm - Inch 16

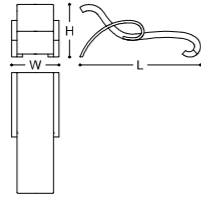

CODE: 045944 PAL0x, FABRIC TO CHOOSE

FINISHES

SHINY SANTOS ROSEWOOD

ENGADIN

The Engadin daybed features the same lines of the Engadin modular system, though this piece is conceived to be placed independently. Its design features two rounded armrests, typical of the range, and a long cushion of 80x170 cm which functions as a mattress. Since this daybed has no backrest, it is ideal to place in the middle of a room. Upholstery available in all Armani/Casa fabrics, or thin and Soft Touch Leathers in collection. Fabric covers are not removable.
MADE IN ITALY.

DIMENSIONS
223x80x75h cm - Inch 31.5x87.8x29.5h

SH: 44 cm - Inch 17.3

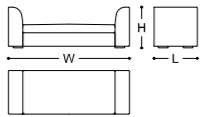

CODE: 048542 CT00E TX027, NANJING FABRIC





ONDA

The Onda chaise-longue takes inspiration from the Morfeo bed: both ranges were born from the idea of a folded paper sheet, creating a sinuous silhouette made with a unique piece. The frame of the chaise-longue is made with solid wood, while the central part is covered with different materials depending on the version. Onda is equipped with a thin mattress and a movable cushion upholstered with fabric, in a color matching the main material of the structure. Onda is available with or without armrests. MADE IN ITALY.

DIMENSIONS
185x80x85h cm - Inch 72.8x31x33.4h
SH: 35 cm - Inch 13.7

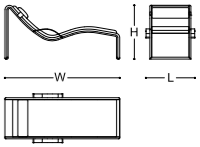

* CODE: 050112 CH997 ER062, SINGAPORE FABRIC

FINISHES

- | | | | |
|---|---|---|--|
|  |  |  | CANALETTO WALNUT / DARK GREEN INTERWOVEN LEATHER / MELBOURNE FABRIC (ER003 - MINT) |
|  |  |  | CANALETTO WALNUT / JAPAN RED SOFT TOUCH LEATHER / SINGAPORE FABRIC * |
|  |  |  | CANALETTO WALNUT / TECHNICAL CHINCHILLA FABRIC / LUXEMBOURG FABRIC (TR814 - IVORY) |

PRETTY

Dedicated to cinema actresses from the Twenties and the Thirties, this dormeuse called Pretty was conceived as a hero piece to be placed centrally in a room, thanks to its curved lines that can be admired from all perspectives; the rounded shapes, emphasized by the platinum-lacquered base, are made lighter by the wide empty space below the seat. The off-centered backrest - available both in right and left option - makes this charming piece of furniture suitable for being used also as a small sofa. Available in all Armani/Casa fabrics and Soft Touch Leathers in collection; covers are not removable.
MADE IN ITALY.

DIMENSIONS
208x88x75h cm - Inch 81.9x34.6x29.5h
SH: 44 cm - Inch 17.3

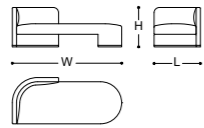

CODE: 050383 CT00B TX140, PERUGIA FABRIC

FINISHES
PLATINUM LACQUER

DAKAR

Stool with upholstered seat. Inner padding in polyurethane foam and visible wooden legs. Dakar can be upholstered also with housse covers. Upholstery available in all suitable Armani/Casa fabrics or Soft Touch Leathers in collection.
MADE IN ITALY.

DIMENSIONS
38x38x45h cm - Inch 15x15x17.7h

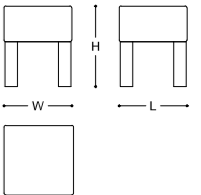

CODE: 045005 RMA0C TR813, LUXEMBOURG FABRIC

FINISHES
BRUSHED BROWN OAK

FIGARO

This footrest/stool is designed starting from the lines of its matching chair: the legs and upholstered seating of the two pieces, in fact, have the same dimensions. With a height of 45 cm, this piece is taller than a normal footrest and it is adaptable to various situations. The seat is padded with variable density foam to ensure a higher comfort. Legs feature 15 mm metal feet matching their respective wood. The upholstery is available in all and suitable Armani/Casa fabrics or Soft Touch Leathers in collection. Fabric covers are removable.
MADE IN ITALY.

DIMENSIONS
57x43x45h cm - Inch 22.4x16.9x17.7h

SH: 45 cm - Inch 17.7

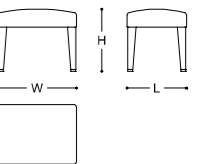

STRUCTURE AND UPHOLSTERY AVAILABLE IN THE LISTED OPTIONS ONLY

FINISHES
BRUSHED BROWN OAK CANALETTO WALNUT

GARDENIA

Gardenia is an upholstered bench that can either be used as an end-of-bed bench or singularly inside a room. Thanks to its neutral design it can easily be placed with all kinds of beds. Completely padded and upholstered, this bench is marked by its frame kept above ground by two metal x-shaped bases, characteristic in the Armani/Casa design line: the same base structure, in fact, can be found on Club, Damasio and Oreste. Upholstery in all suitable Armani/Casa fabrics or Soft Touch Leathers; fabric covers are removable. MADE IN ITALY.

DIMENSIONS
170x45x48h cm - Inch 66.9x17.7x18.9h

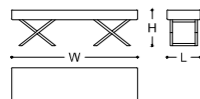

FINISHES

BRUSHED BROWN OAK



SMOKED GOLD *

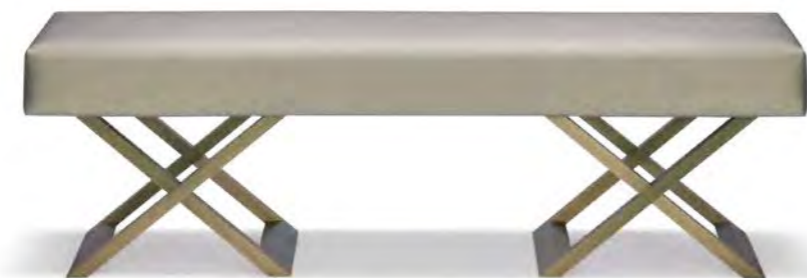

* CODE: 048543 CT00A TX155, PARMA FABRIC

GLAM

The Glam stool was born to complete the related coiffeuse and is available in a single size. It has a simple but functional design: the seat features curved sides and tubular metal legs with squared section. Differently from the matching coiffeuse, the stool can be upholstered with different materials - like all suitable Armani/Casa fabrics and Soft Touch Leathers in collection - becoming a multifunctional piece. Fabric covers are removable. MADE IN ITALY.

DIMENSIONS
60x40x45h cm - Inch 23.6x15.7x17.7h

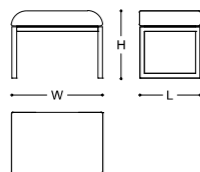

FINISHES

PARMA FABRIC /
SMOKED GOLD



CODE: 048546 CT00A TX154, PARMA FABRIC

LAWRENCE

Rounded shape footrest. Available in two different sizes, large and small, that can be matched for several décor options. Upholstery available in all suitable Armani/Casa fabrics, Thin Leathers and Technical Shagreen Fabric. Base in bronze lacquer. This sinuous footrest is particularly decorative if upholstered with Lafayette fabric by Rubelli, featuring a Japanese landscape motif. MADE IN ITALY.

DIMENSIONS
SMALL: 55x41x43h cm - Inch 21.7x16.1x17h
LARGE: 85x57x43h cm - Inch 33.5x22.4x17h

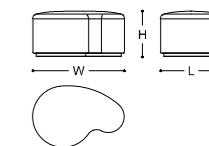

CODE: 048932 TES71 C0041 (LARGE) - 048931 TES71 C0041 (SMALL)



CODE: 048932 CT00D ER040 (LARGE), 048931 CT00D ER040 (SMALL), ROSTOV FABRIC

REMY

Remy is a range of ottomans comprising a bench and small stools. The modern design is marked by the Z-shaped base structure, made with remnants of solid wood panels used for larger furniture: in this way, Armani/Casa continues the commitment of the Armani Group in sustainability. The upholstery can be selected among all fabrics and Soft Touch Leathers in collection, plus a special fabric (available on this range only) with a three-dimensional surface imitating an alligator rawhide. All covers are not removable. The stool is available also without upholstered parts, so that it can be used as a small table. The stool without upholstery can be completed by adding a thick leather (cuoio) pad - to be bought separately - available in different colors, in order to make the seat more comfortable. MADE IN ITALY.

DIMENSIONS
UPHOLSTERED BENCH:
170x40x46h cm - Inch 66.9x15.7x18.1h

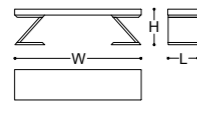

STOOL:
40x40x46h cm - Inch 15.7x15.7x18.1h

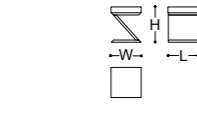

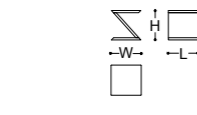

STOOL/SMALL TABLE:
40x40x40h cm - Inch 15.7x15.7x15.7h



* CODE: 050585 NOCOA TX155, PARMA FABRIC

FINISHES

-  CANALETTO WALNUT *
-  BRUSHED BLACK ASHWOOD



* CODE: 050586 TS130 ER042



* CODE: 050587 CA918 C9553

RODEO

The Rodeo range includes oval upholstered footrests/low stools available in two sizes. The main feature of this range is the tubular base - covered in thick leather (cuoio) and featuring metal details - that keeps those pieces lifted from the floor (6 cm). The large size is available in two versions, a fixed one and another that can be opened to access a container unit. Available in all fabrics and Soft Touch Leathers in collection. Covers are not removable. MADE IN ITALY.

DIMENSIONS
SMALL:
60x40x43h cm - Inch 23.6x15.7x16.9h

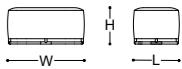

LARGE (WITH OR WITHOUT CONTAINER):
85x50x43h cm - Inch 33.4x19.6x16.9h









* CODE: 050658 CT00C ER064 (LARGE), 050657 CT00C ER064 (SMALL), SAO PAULO FABRIC



** CODE: 050658 CT00D TX163 (LARGE), 050657 CT00D TX163 (SMALL), RIVOLI FABRIC

FINISHES

-   COGNAC LEATHER (CUOIO) / SATIN LIGHT BRASS **
-   CORTECCIA BROWN LEATHER (CUOIO) / SATIN LIGHT BRASS *
-   DOVE GREY LEATHER (CUOIO) / SATIN LIGHT BRASS

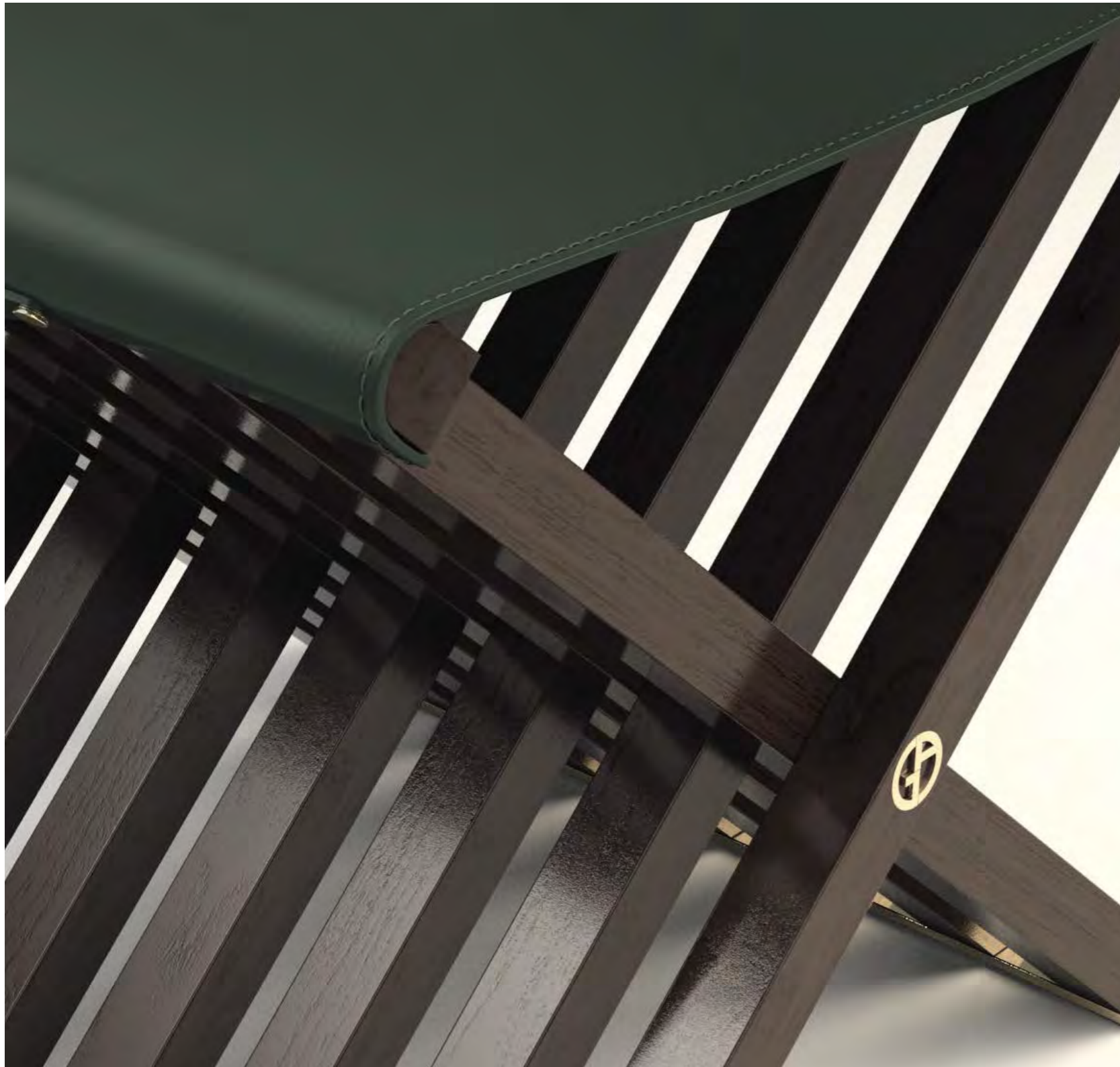

ROXY

Foldable stool in solid walnut and seat in thick leather (cuoio). The X-shaped legs move around a pivot enriched by the metal GA logo. From the side view, the legs show a structure made of several wooden laths. Roxy features tiny leather handles on the sides, to make the transport easier. Available in different leather (cuoio) colors. MADE IN ITALY.

DIMENSIONS
48x42x42h cm - Inch 18.8x16.5x16.5h

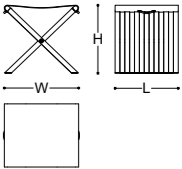

CODE: 050374 CA900 C0586



CODE: 050374 CA900 C0554



CODE: 050374 CA900 C0151

FINISHES



CANALETTO WALNUT / SATIN LIGHT BRASS / LEATHER (CUOIO) TO CHOOSE

DALLAS

Dallas is a classic chair with essential lines. Upholstery available in all Armani/Casa fabrics, Leathers (cuoio) and Soft Touch Leathers in collection. Covers are not removable.
MADE IN ITALY

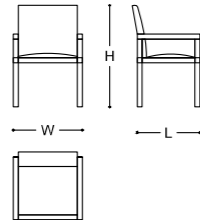
DIMENSIONS
55x53x81h cm - Inch 21.6x20.9x31.9h
SH: 42cm - Inch 16.5



- FINISHES**
-  BRUSHED BROWN OAK *
 -  PLATINUM LACQUER



* CODE: 045006 RMA0x, FABRIC TO CHOOSE

FIGARO

The Figaro chair is particularly comfortable, thanks to its soft padding and the inclined seat; moreover, the seat is higher than normal (cm 49,5). Figaro is available with tall or low backrest: the tall version better suits a dining table and has exactly the same height of the Dalia chair, so that both can be placed around the same table (Figaro at the ends, Dalia on the sides). Upholstery available in all suitable Armani/Casa fabrics or Soft Touch Leathers in collection.
MADE IN ITALY.

DIMENSIONS
TALL: 57x62,5x102h cm - Inch 22.5x24.6x40.2h
SH: 49,5 cm - Inch 19.5
LOW: 57x62,5x90h cm - Inch 22.5x24.6x35.4h

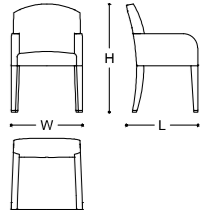

CODE: 048671 RMA0x, FABRIC TO CHOOSE

- FINISHES**
-  BRUSHED BROWN OAK



JYLIA

Jylia is an elegant dining chair with rounded profiles, featuring a clear Eastern inspiration. The curved tapered seatback continues in the back legs. The Jylia chair combines different materials like leather (seatback and armrests) and lacquer (legs and base). The seat of the red version can be upholstered with Jinhua fabric (color Jade Green/Ruby Red - TR775), Nagano fabric (color Petroleum/ Red/Gold - TX023), Sao Paulo fabric (color Rust/Red/Viridian - ER064) or Red Leather. The blue and the green versions are available in leather and lacquer only. The version in Brushed Honey Ashwood, instead, can either be upholstered in Sao Paulo fabric (color Pale Gold/Platinum/Grey - ER065) or Siracusa fabric (color Sage - ER049).
MADE IN ITALY.



* CODE: 048872 CA962 C1336

DIMENSIONS
58,5x55,5x88,5h cm - Inch 23x21.8x34.8h
SH: 48,5 cm - Inch 19.1

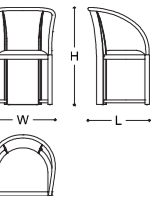

** CODE: 048872 CH954 ER049, SIRACUSA FABRIC

FINISHES

-   HAZELNUT MIDOLLINO / BRUSHED HONEY ASHWOOD **
-   DARK BLUE LEATHER (CUOIO) / DARK BLUE LACQUER *
-   DARK GREEN LEATHER (CUOIO) / FOREST GREEN LACQUER
-   RED LEATHER (CUOIO) / RED LACQUER

LEA

Upholstered chair featuring a sinuous design, with large curved armrests and seatback to ensure higher comfort and ergonomics. Cantilever seat. Depending on the colour, the inside of the seat is refined with Soft Touch Leather or Thin Leather, while the outside is always in Leather (cuoio) of the same tone: Black, Cognac, Dark Green, Dove Grey or Red. The chair features a decorative zip around the edge. Lea is available with tapered legs in Canaletto Walnut with C-shaped section, or with a metal base in hand-polished brass for the swivel option. MADE IN ITALY.

DIMENSIONS
60x72x86h cm - Inch 23.6x28.3x33.8h

SH:
FIXED OPTION: 50 cm - Inch 19.7

SWIVEL OPTION:
min. 45/max. 51 cm - Inch min. 17.7/max. 20

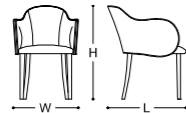

* CODE: 050001 CA900 C0586

FINISHES FIXED OPTION

 CANALETTO WALNUT / LEATHER *

FINISHES SWIVEL OPTION

 SATIN LIGHT BRASS / LEATHER **



** CODE: 050590 CA900 00151

MADDALENA

Maddalena is a dining chair with armrests. The rear legs of Maddalena have a structure that continues in the backrest to create a single piece, in aluminum like the other parts to ensure lightness. The base structure of the front legs, instead, continues in the armrests and grants more stability. The entire structure is covered with thick Tuscanian leather (cuoio). MADE IN ITALY.

DIMENSIONS
54x54x91h cm - Inch 21,2x21,2x35,8h

SH: 48 cm - Inch 19.9

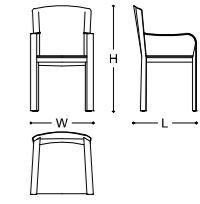

FINISHES

 BLACK LEATHER (CUOIO)

 CORTECCIA BROWN LEATHER (CUOIO)

 DARK BLUE LEATHER (CUOIO)

 DARK BROWN LEATHER (CUOIO)

 DARK GREEN LEATHER * (CUOIO)

 DOVE GREY LEATHER (CUOIO)

 RED LEATHER (CUOIO)



* CODE: 049325 CA185 C5286

NATHALIE

Nathalie is an enveloping dining chair inspired the shape of the iconic Classic chair by Armani/Casa, but with a wider seat. Nathalie features upholstered seat and seatback, with a visible wooden structure in solid Canaletto Walnut. The four legs continue uninterrupted to support the seatback. Nathalie can be upholstered with all suitable Armani/Casa fabrics, Thin Leathers and Soft Touch Leathers in collection. MADE IN ITALY.

DIMENSIONS
63x61x80h cm - Inch 25x24x31.5h

SH: 48 cm - Inch 18.9

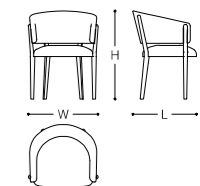

FINISHES

 CANALETTO WALNUT



CODE: 048962 NOCOE TX033, NANJING FABRIC

PEGGY

The Peggy range comes from the idea of an enveloping and light seat, inspired by the multi-faceted figure of Peggy Guggenheim. The sinuous lines carved in the solid wood define an elegant functional silhouette. The result is a chair with sculptural yet very feminine aesthetics, paying a tribute to the love the famous collector had for *avant-garde*. The relax version is perfect for being placed in a studio, a conversation area or a bedroom. Upholstery available in all suitable Armani/Casa fabrics or Soft Touch Leathers in collection; covers are not removable. MADE IN ITALY.

DIMENSIONS
DINING VERSION:
 62x56x75h cm - Inch 24.4x22x29.5h

SH: 47 cm - Inch 18.5

RELAX VERSION:
 76x66x71h cm - Inch 30x26x28h

SH: 44 cm - Inch 17.3

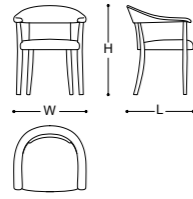

** CODE: 050355 NOCOE TX166, RAVENNA FABRIC



* CODE: 050354 FOR0E TX145, PORTO FABRIC

FINISHES DINING VERSION

- BRUSHED BLACK ASHWOOD
- CANALETTO WALNUT **

FINISHES RELAX VERSION

- BRUSHED BROWN OAK
- CANALETTO WALNUT
- BRUSHED BLACK ASHWOOD
- ROSE SILVER LEAF *

RIMA with armrests

Dining chair with upholstered seat and seatback. The reverse of the seatback features a carved structure with a cut out geometric motif that leaves the upholstery visible from behind. Rima can be upholstered with all suitable Armani/Casa fabrics or Soft Touch Leathers in collection. MADE IN ITALY.

DIMENSIONS
 53,5x57x93,5h cm - Inch 21x22.4x36.8h

SH: 49 cm - Inch 19.3

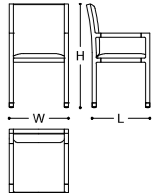

CODE: 045604 RMA0D TX037, NOTO FABRIC

FINISHES

- BRUSHED BROWN OAK

DUSTIN

Dustin is a director's chair designed for one of Giorgio Armani's yachts, and it is available in different versions. The first one is foldable and presents a visible wooden structure combined with all Soft Touch Leathers in collection, plus a Thin Leather option for the Vintage Brown Oak structure. The second version of Dustin is entirely covered with Thin Leather and cannot be folded. The elm version is matched with leather (cuoio) in Black, Corteccia Brown, Dark Brown, Dark Green, Dove Grey or Red. The version in Brushed Honey Ashwood can be combined with Cognac leather (cuoio) only. MADE IN ITALY.





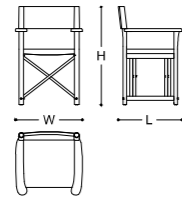

DIMENSIONS
59x55x85h cm - Inch 23.2x21.7x33.5h

SH: 48 cm - Inch 18.9



* CODE: 048132 CA952 C0554, THIN LEATHER

FINISHES

-  BROWN ELM
-  BROWN MAHOGANY
-  BRUSHED BROWN OAK
-  BRUSHED HONEY ASHWOOD / COGNAC LEATHER (CUOIO) **
-  CANALETTO WALNUT
-  VINTAGE BROWN OAK *



** CODE: 048132 CH994 C2554

DALIA

Dalia is a high comfort dining chair with flowing lines, which offers many customizable options. In fact, Dalia is available with or without house, and without house it can be selected with wooden legs or completely upholstered. In the wooden legs option, the seat and the seatback can be upholstered with all Soft Touch Leathers or suitable Armani/Casa fabrics in collection. Thin Leather can be selected only in combination with Canaletto Walnut. The completely upholstered version, instead, features padded legs and Satin Natural Brass feet. In this case, the upholstery can be selected among all Soft Touch Leathers, suitable Armani/Casa fabrics or Technical Shagreen Fabric. A particularly elegant version features Maranello velvet on the seat and decorative Lafayette fabric on the seatback, in matching tones. The insertion of a handle on the reverse of the seatback is an extra optional feature. A protective mini slip cover can be ordered separately. MADE IN ITALY.

DIMENSIONS
46,2x65,2x102h cm - Inch 18.2x24.6x40.2h

SH: 51 cm - Inch 20.1

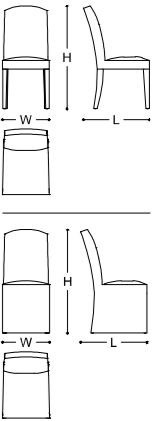





* CODE: 048151 LVV0E TX019 , NAGANO FABRIC



CODE: 048151 TS076 TR855, LAFAYETTE / MARANELLO FABRICS

FINISHES

-  BLACK MAPLE
-  CANALETTO WALNUT
-  BROWN MAHOGANY
-  VERONESE GREEN LACQUER *
-  BRUSHED BROWN OAK

GIOTTO

Giotto is a simple but very elegant chair. It features a 1cm air between the seat and the rounded legs, for a lighter look. The padding is in polyurethane of different densities while the back is curved and slightly flexible, in order to be more comfortable and ensure the right ergonomics. The upholstery can be selected in all suitable Armani/Casa fabrics or Soft Touch Leathers in collection. It is also available in Thin Leather. Covers in fabric are completely removable.

MADE IN ITALY.

DIMENSIONS
46x55x85h cm - Inch 18.1x21.7x33.5h

SH: 48 cm - Inch 18.9

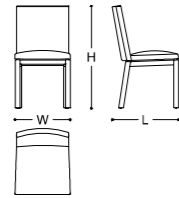

* CODE: 048523 NOCOD TR848, LILLE FABRIC

FINISHES

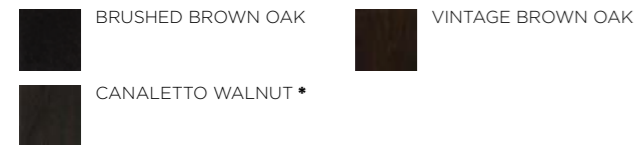

OTTO

Otto is a chair with low backrest. The inner foam structure of the backrest allows a slight flexibility. Seat and backrest can be upholstered with all Soft Touch Leathers in collection or suitable Armani/Casa fabrics.

MADE IN ITALY.

DIMENSIONS
45x49x90h cm - Inch 17.7x19.3x35.4h

SH: 48 cm - Inch 18.7

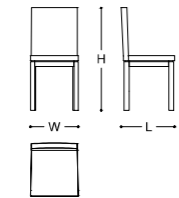

* CODE: 048670 NOCOA ER048, SIRACUSA FABRIC

FINISHES

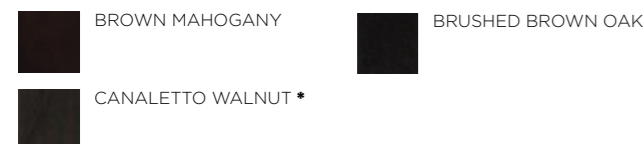

OMAGE

Omage is a dining chair marked by a light silhouette, featuring a structure in solid wood. The structure of the seatback continues in the rear legs, creating a unique element. Since the wooden structure is very discrete and leaves the upholstery perfectly visible also from behind, Omage is a perfect match with very decorative fabrics. Upholstery available in all suitable fabrics, Thin and Soft Touch Leathers in collection. Covers are not removable.

MADE IN ITALY.

DIMENSIONS
45x55x89h cm - Inch 17.7x21.6x35h

SH: 48 cm - Inch 18.7

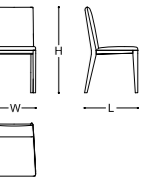

* CODE: 050101 RMA0D Txxxx, FABRIC TO CHOOSE

FINISHES

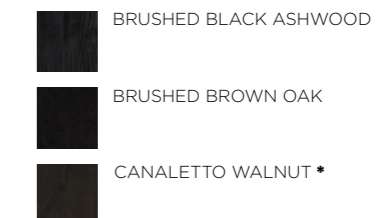

PRISMA

Prisma is a dining chair conceived to match the Page dining table. The structure of this chair is entirely made with solid wood. The rigorous look, defined by right angles, is softened by the slightly tilted padding of the seatback. Upholstery available in all suitable Armani/Casa fabrics and Soft Touch Leathers in collections. Covers are not removable. MADE IN ITALY.

DIMENSIONS
45x54x100h cm - Inch 17.7x21.2x41.3h

SH: 48 cm - Inch 18.9

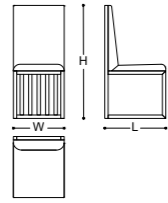

CODE: 050384 TT030 TX121, PIACENZA FABRIC

FINISHES

 BRUSHED HONEY ASHWOOD

RIMA without armrests

Dining chair with upholstered seat and seatback, without armrests. The first version features the reverse of the seatback showing a distinctive carved structure with a cutout geometric motif that leaves the upholstery visible from behind. The second version, instead, features a reverse of the seatback with the outer frame only (with no geometric carving) that leaves the upholstery visible from behind. Rima can be upholstered with all suitable Armani/Casa fabrics or Soft Touch Leathers in collection. MADE IN ITALY.

DIMENSIONS
43,5x52x93,5h cm - Inch 17.1x20.5x36.8h

SH: 49 cm - Inch 19.3

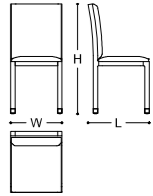

* CODE: 049335 LN00C TX126, PALERMO FABRIC

FINISHES

 BLACK LACQUER *

 BRUSHED BROWN OAK

ROSLIN

Roslin shares the concept behind the Morfeo bed and the Onda chaise-longue: the sinuous shape of the chair is made of a single element, curved at the ends, clad in leather and outlined with a wide solid wood frame. The frame continues in the legs of the chair maintaining its reduced thickness. Roslin can be matched with the Rosemond dining table. Available in Cognac or Dove Grey Leathers (cuoio). Covers are not removable. MADE IN ITALY.

DIMENSIONS
46x59x88h cm - Inch 18.1x23.2x34.6h
SH: 46 cm - Inch 18.1

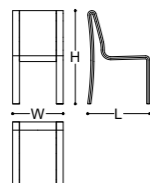

* CODE: 050361 CH181 00151

FINISHES



ANDROMEDA

Small upholstered chair with Brushed Brown Oak feet. It is available in all Soft Touch Leathers or suitable Armani/Casa fabrics in collection. Covers are not removable. MADE IN ITALY.

DIMENSIONS
69x61x76h cm - Inch 27.2x24x29.5h
SH: 46 cm - Inch 18.1

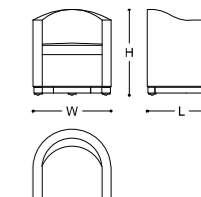

CODE: 045592 RMA0x xxxxx, FABRIC TO CHOOSE

FINISHES

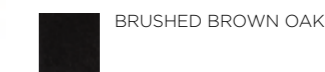

CLASSIC

Tub chair for dining tables and desks. The Classic range offers an extremely curved seat marked by a plain minimalism. The seat outer structure has a wide choice of wood finishing with matching metal base. Seat, armrests and backrest can be lined with all suitable Armani/Casa fabrics or Soft Touch Leathers in collection. Thin Leather is available only on the Canaletto Walnut structure. The rosewood version can be matched also with lizard effect leather. Covers are not removable. MADE IN ITALY.

DIMENSIONS
62x56x77h cm - Inch 24.2x22x30.3h

SH: 42 cm - Inch 16.5

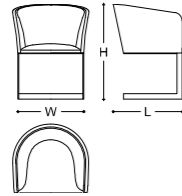

* CODE: 048010 ACEOP P0402, SOFT TOUCH LEATHER

FINISHES

-   BLACK MAPLE / BLACK PAINTED STEEL *
-   BRUSHED BROWN OAK / BRONZED BRASS
-   CANALETTO WALNUT / SATIN LIGHT BRASS
-   PLATINUM LACQUER / SATIN LIGHT BRASS **
-   SHINY SANTOS ROSEWOOD / BRONZED BRASS
-   VINTAGE BROWN OAK / SATIN BLACK NICKEL
-   VINTAGE BROWN OAK / SMOKED GOLD



** CODE: 050121 CA779 TX102, OLBIA FABRIC

BAR

Tall stool with metal structure, perfect for breakfast corners in the kitchen or bar areas in the living room. Upholstery available in all suitable Armani/Casa fabrics or Soft Touch Leathers in collection. Available in two heights. MADE IN ITALY.

DIMENSIONS
LOW: 42x47x93h cm - Inch 16,5x18,5x36,6h
SH: 65 cm - Inch 25.6

TALL: 42x47x103h cm - Inch 16,5x18,5x40,5h
SH: 75 cm - Inch 29.5

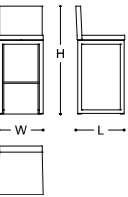

CODE: 045974 MNSOA ER024, RIGA FABRIC

FINISHES

-  SATIN BLACK NICKEL

TABLES

- DINING TABLES
- CONSOLES
- SMALL AND COFFEE TABLES
- BEDSIDE TABLES



PLANET Dining table/PARSIFAL Vases

NELSON

The distinctive feature of the Nelson range is the suspended rectangular top, which makes the whole structure look particularly light. Legs have a bridge shape with a rectangular section. Nelson is available in three different finishes: the first has a base structure in Antique Brown Oak and top/ legs in Antique Gold Leaf, while the second presents a luxurious Shiny Bronze Straw Marquetry top with an all-over pattern, matched with a matt Black Maple structure and methacrylate legs. Both versions are available with extensions (240 cm only). The third version, instead, features a top in Limestone framed with Honey Maple and legs in Honey Maple and Halzenut Midollino.

MADE IN ITALY.

DIMENSIONS

240x110x75h cm - Inch 94.4x43.3x29.5h
 280x110x75h cm - Inch 110x43.3x29.5h*
 *Gold leaf option only

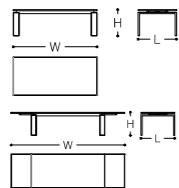

EXTENDABLE VERSION

The extendable version features external extensions of 65 cm.

FINISHES

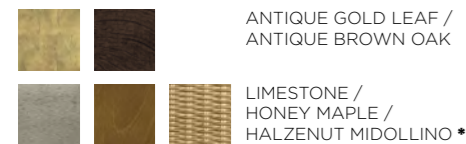

* CODE: 049113 CH988 C3555 (240 CM)

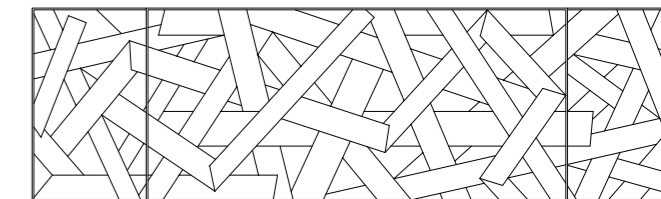

Simulation of the top in straw marquetry. Since it is totally hand made, the real design could slightly change and be different on each piece. For those reasons, this simulation must be considered an example only and not the exact reproduction of the final result.

FINISHES

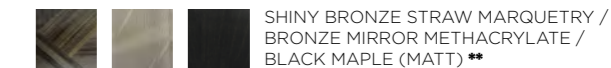

** CODE: 049113 CA178 C0056 (240 CM)

NATHAN

Nathan is a dining table inspired by the Matrix collection of consoles, recalled by the extra thin tops (1 cm - Inch 0.4) and the metal legs with triangular section. The use of special finishes enriches the clean, elegant lines of the table, almost recalling the sartorial precision of a made-to-measure suit. The outer side of the legs is in the same finish of the top.
MADE IN ITALY.

DIMENSIONS
240x110x75h cm - Inch 94.4X43.3x29.5h
270x110x75h cm - Inch 106.2X43.3x29.5h

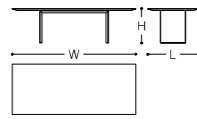

FINISHES
BLACK CRACKLED LACQUER / SATIN LIGHT BRASS

CODE: 045661 CA439 C0020 (270 CM)

PAGE

Page is a rectangular dining table, whose look catches the eye thanks to the particular base structure. In fact, legs are made of different wood laths (each with section of 3 x 5 cm) placed with a distance of 3 cm in between them: this feature creates an alternance of full and empty spaces, giving this important structure a lighter appearance. All laths of the same leg are connected at the base by a feet in Lacquer. Another important detail is the horizontal bar that connects the legs and runs below the top. The top has a thickness of 5 cm. Page is available in two versions. The first is in Brushed Honey Ashwood with top in Crisscross Natural Straw, whose striped design recalls the laths of the table; The second is entirely in Brushed Brown Ashwood, featuring a top in solid wood. The material used for this second version is sustainable, since comes from the excess of solid wood not used for other furniture: no additional trees are cut to obtain the raw material.
MADE IN ITALY.

DIMENSIONS
240x105x75h cm
Inch 94.5x41.3x29.5h
270x105x75h cm
Inch 106.3x41.3x29.5h

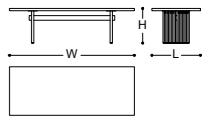

* CODE: 050344 CH036 C0053 (270 CM)



FINISHES
BRUSHED BROWN ASHWOOD / BRONZE LACQUER *
BRUSHED HONEY ASHWOOD / CRISSCROSS NATURAL STRAW / PLATINUM LACQUER **

** CODE: 050344 CH035 C0014 (270 CM)

PILLAR

Pillar was born from the idea of combining a sleek design with a strong vintage accent. The inspiration for Pillar came from the so called «fratina» style, the typical dining tables used in monasteries during the Middle Age and conceived to increase conviviality. In our version, the distance from the legs to the edge of the top is 38 cm: in this way, people sitting close to the legs have all the space necessary to feel comfortable. The rigorous look of this classic shape has been modernized by the use of exclusive finishes that perfectly match the other iconic pieces by Armani/Casa. Pillar is presented in two versions, both with contrasting colors for what concerns top and the legs. The first one has a top in Striped Black Lacquer and legs in Shiny Beige Ashwood, while the second features a top in Brushed Black Ashwood and legs always in Shiny Beige Ashwood. MADE IN ITALY.

DIMENSIONS
240x105x75h cm
Inch 94.5x41.3x29.5h

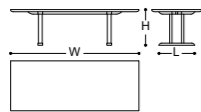

270x105x75h cm
Inch 106.3x41.3x29.5h

FINISHES

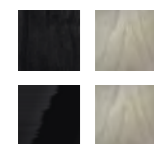

BRUSHED BLACK ASHWOOD /
SHINY BEIGE ASHWOOD *

STRIPED BLACK LACQUER /
SHINY BEIGE ASHWOOD



* CODE: 050360 CH042 C0020 (270 CM)

ROSEMOND

Dining table available in rectangular or squared shape. Rosemond features flush legs in metal, contrasting with the top in wood. The legs also work as top frame on two sides (the longest ones for the rectangular version). The visual lightness of this piece is given by the reduced thickness all elements (visible edge of 25 mm). MADE IN ITALY.

DIMENSIONS
RECTANGULAR VERSION:
210x105x75h cm - Inch 82.6x41.3x29.5h

SQUARED VERSION:
160x160x75h cm - Inch 62.9x62.9x29.5h

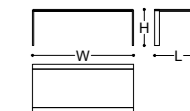

CODE: 050615 CH187 C0053

FINISHES



BRUSHED BROWN ASHWOOD /
SATIN LIGHT BRASS

SPACE

Space is a square dining table with transparent legs, made of methacrylate. The top is either available in Canaletto Walnut or in Striped Greige Lacquer. The latter is characterised by the illusion of a three-dimensional *canneté*, typical of the Armani style, lacquered with a glossy finish.
MADE IN ITALY.

DIMENSIONS
140x140x75h cm
Inch 55.1x55.1x29.5h

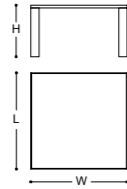

* CODE: 050752 CA918 C0053



** CODE: 050752 CH963 C1842

FINISHES

-   CANALETTO WALNUT / TRANSPARENT METHACRYLATE *
-    STRIPED GREIGE LACQUER / PLATINUM LACQUER / TRANSPARENT METHACRYLATE **







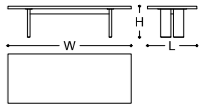



TROCADERO

Trocadero is the most iconic Armani/Casa table. Its silhouette is marked by the design of the four legs, placed so that they create the illusion of only two monolithic elements below the table top. Trocadero can be customized by choosing among four different sizes and many finishes, from classic to more particular ones. Options with two materials refer to the finishing of the top and of the legs respectively. The version with Brushed Greige Oak presents a top covered by tempered extra-clear glass.
MADE IN ITALY.

DIMENSIONS
210x105x75h cm - Inch 82.7x41.3x29.5h
240x105x75h cm - Inch 94.5x41.3x29.5h
270x110x75h cm - Inch 106.3x43.3x29.5h
300x120x75h cm - Inch 118.1x47.2x29.5h



FINISHES

-   BLACK DRAFTED STUCCO / SATIN BLACK NICKEL
-  BRUSHED BROWN OAK
-   BRUSHED BROWN OAK / SATIN BLACK NICKEL
-   BRUSHED GREIGE OAK / BLACK LACQUER *
-   MUD DRAFTED STUCCO / SATIN BLACK NICKEL
-   PATINATED LINEN / BLACK MAPLE
-   WHITE GOLD DRAFTED STUCCO / SATIN BLACK NICKEL



* CODE: 048345 CA975 C0020 (270 CM)



JINGO

Jingo is a round dining table featuring a precious top and four legs with triangular section. The top is in Calacatta Oro Marble, while the legs are in handwoven Hazelnut Midollino. MADE IN ITALY.

DIMENSIONS
 Ø 160x75h cm - Inch 62.9x29.5h

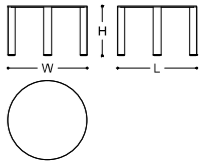

CODE: 048875 CH991 C3555

FINISHES



CALACATTA ORO MARBLE /
 HAZELNUT MIDOLLINO /

MELROSE

The Melrose range includes a set of two round coffee tables and a round dining table. The dining table features four legs and a base structure in metal. The curved legs are built directly into the metal profile of the top. The top is in wood and has a reduced thickness of only 2,2 cm, to highlight the concept of lightness. MADE IN ITALY.

DIMENSIONS
 Ø 130x75h cm - Inch Ø 51.1x29.5h

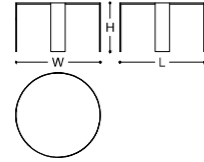

CODE: 049309 CA899 C9453

FINISHES



NED

Ned is a round table available in two sizes, for six or nine people. It features some distinctive details like the elliptical legs - in solid wood - close to the top edge and the horizontal bars jointing them. The top is divided into three sections featuring Tamo veneer. The horizontal bars, which grant more stability to the whole structure, become also a decorative element since they are entirely covered with leather (cuoio). MADE IN ITALY.

DIMENSIONS
 Ø 160x75h cm - Inch Ø 62.9x29.5h
 Ø 200x75h cm - Inch Ø 78.7x29.5h

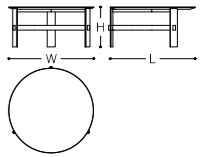

CODE: 045983 CA102 C0554 (160 CM)

FINISHES

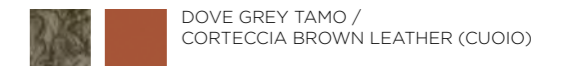

PLANET

The table Planet extends the range of round tables by Armani/Casa, inserting an option that features the X-shaped legs typical of our brand. The X shape immediately echoes other iconic ranges from our collection, like the Oreste small table and the Club cocktail cabinet. The structure - featuring legs and frame of the top in solid wood - is very light thanks not only to the slim legs, but also to a visual effect created by the top, that has a 4 cm thickness that reduces toward the edges. The Planet range also includes an accessory, the *Lazy Susan* (an optional rotating tray, to be bought separately) available in different materials. MADE IN ITALY.

DIMENSIONS
 Ø 160x75h cm - Inch Ø 63x29.5h
 Ø 180x75h cm - Inch Ø 70.8x29.5h

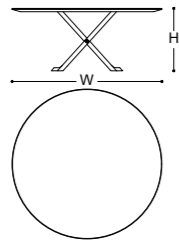

Lazy Susan:
 Ø 80x3,5h cm - Inch Ø 31.4x1.3h
 Ø 100x3,5h cm - Inch Ø 39.3x1.3h





* CODE: 050363 CA906 C1554 (180 CM) / 050397 CA179 C1043 (LAZY SUSAN)

FINISHES

-   BROWN TAMO / SATIN LIGHT BRASS *
-   CANALETTO WALNUT / SATIN LIGHT BRASS **
-   BRUSHED BLACK ASHWOOD / SATIN LIGHT BRASS

Lazy Susan

-  BLACK GLASS
-  GREY COLOMBIAN MARBLE



** CODE: 050363 CA918 C9553 (180 CM)



ENYA

The Enya console is available in a low and a tall version. Enya low is made specifically to be positioned on the back of the 3 seats Canaletto sofa and similar, but can also be used as a low console. Enya tall to be used in an entrance/corridor, a living room or behind sofas with higher backrests like Engadin or London. The design is the same for all size options, with a slight difference for the longest versions: for technical reason, in fact, they feature an additional central leg that reaches the top, dividing the shelves in two. MADE IN ITALY.

DIMENSIONS

ENYA TALL

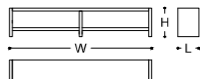

100x44x75h cm - Inch 39.4x17.3x29.5h
 150x44x75h cm - Inch 59.1x17.3x29.5h
 205x44x75h cm - Inch 80.7x17.3x29.5h
 285x44x75h cm - Inch 116.1x17.3x29.5h



ENYA LOW

282x44x60h cm - Inch 111x17.3x23.6h
 298x44x60h cm - Inch 117.3x17.3x23.6h
 312x44x60h cm - Inch 122.8x17.3x23.6h
 328x44x60h cm - Inch 129.1x17.3x23.6h

FINISHES EXTENDABLE VERSION

-  BLACK MAPLE
-  BRUSHED BROWN OAK *



* CODE: 048675 CA336 C0053 (328 CM)

EVANS



The Evans console features a hidden storage compartment closed by a flap door. Available in one size only, this console is made of a suspended central element and two built-in flush legs in metal with square section placed on the sides. The hidden compartment has no exposed hinges to be almost invisible, and features a slow closing system. MADE IN ITALY.

DIMENSIONS

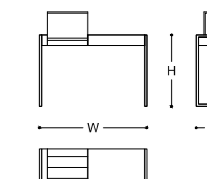
120x36x80h cm - Inch 47.2x14.2x31.5h



FINISHES EXTENDABLE VERSION

-  BRONZE STRAW MARQUETRY / GLOSSY NATURAL BRASS *
-  TECHNICAL SHAGREEN FABRIC / SATIN NATURAL BRASS **



* CODE: 048308 CA825 C0056



** CODE: 048308 CA881 C0041

MANHATTAN

Pedestal table marked by its linear design and the bridge shape.
MADE IN ITALY.

DIMENSIONS
44x44x110h cm - Inch 17.3x17.3x43.3h

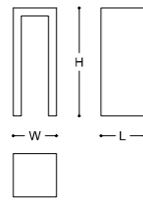

FINISHES

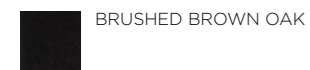

CODE: 041151 CA336 C0053

MATRIX

Four consoles to mix together or display separately. The medium size is perfect also as a coffee table, while the two smaller ones can be used as side/occasional tables. Base structure in metal with triangular section, which creates a particular effect thanks to the reflection of light. Extra thin top of only 1 cm. The Matrix range features the same base structure of the Nathan dining table and of Onyx bookcases.
MADE IN ITALY.

DIMENSIONS
160x40x75h cm
Inch 63x15.7x29h

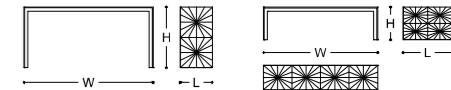

140x60x40h cm
Inch 55x23.6x15.7h

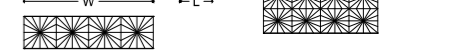

60x60x60h cm
Inch 23.6x23.6x23.6h



60x45x60h cm
Inch 23.6x17.7x23.6h

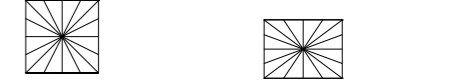
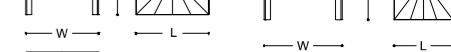

FINISHES



* CODE: 049331 CA885 C0020 (160 CM) / 049330 CA885 C0020 (140 CM) / 049329 CA885 C0020 (60x60 CM)

ORIZZONTE

The Orizzonte console stands out for its neat design, marked by the reduced thickness of the top and the legs. The tubular structure - in metal or covered with leather - embraces the top in a very elegant way.
MADE IN ITALY.

DIMENSIONS
140x40x80h cm - Inch 55.1x15.7x31.4h

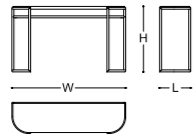

* CODE: 050108 CA941 C4856



** CODE: 050108 CA569 C1084

FINISHES

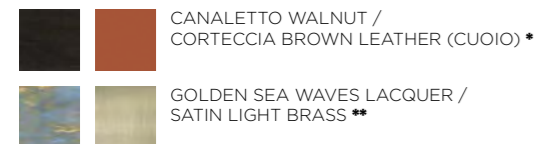

SEINE

Set of three bridge-shaped consoles, made with thick veneered panels. Available in many different finishes, from classic to more particular ones.
MADE IN ITALY.

DIMENSIONS
125x44x70,5h cm - Inch 49.2x17.3x27.8h
148x50x94h cm - Inch 58.3x19.7x37h
180x50x110h cm - Inch 70.9x19.7x43.3h

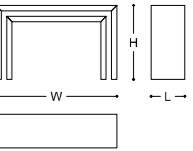

* CODE: 040397 CA862 C0020 (110H CM) / 040393 CA862 C0020 (94H CM)

FINISHES

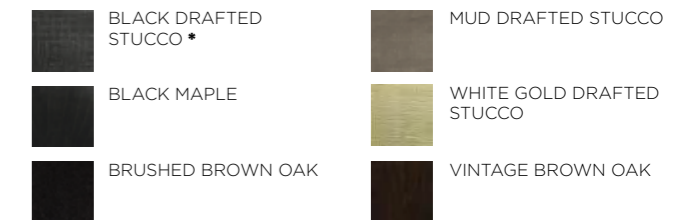

SMART

Smart is a range of pieces matching the already existing Matrix - Mirò - Nathan - Onyx ranges. All these products share the same concept: a bridge-shaped base structure in metal featuring a triangular section, which creates a particular effect thanks to the reflection of light. All Smart pieces are equipped with container units in wood, hosting a different number of drawers. MADE IN ITALY.

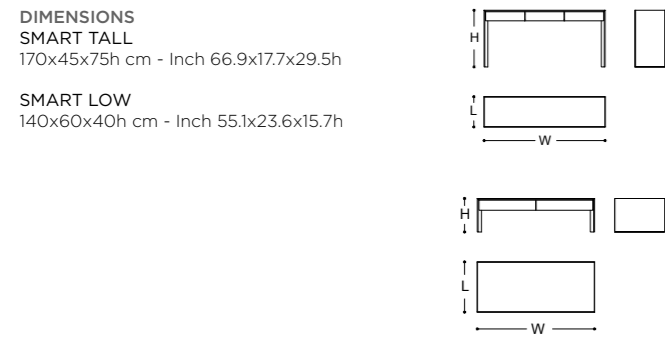

CODE: 050739 CA918 C4856



CODE: 050740 CA918 C4856

FINISHES

CANALETTO WALNUT / SATIN LIGHT BRASS

CANALETTO WALNUT / SATIN NATURAL BRASS *

OFFSET

Offset is a range comprising four different pieces: a console, a large coffee table and two side/small tables. The linear design - featuring a thick wood top and metal legs with squared section - is enriched by a decorative maze motif: to obtained this result, metal inlays are placed in carvings made in the walnut mass directly. Another version, in oak, does not feature the metal maze decoration. MADE IN ITALY.

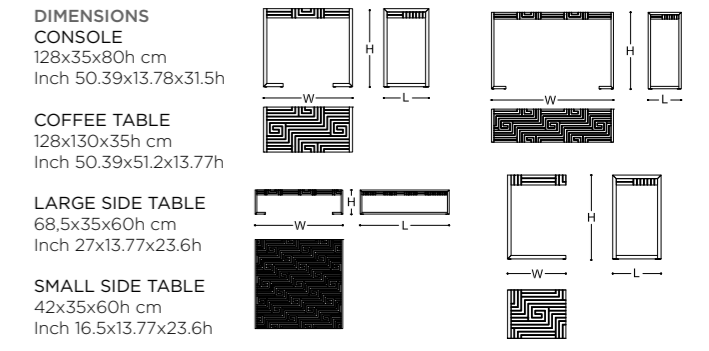

* CODE: 050105 CA986 C4856



* CODE: 050106 CA986 C4856

FINISHES

BRUSHED BROWN OAK / BRONZED BRASS

CANALETTO WALNUT / SATIN NATURAL BRASS *

BOCCHERINI

Small round table with x-shaped legs and metal base.
MADE IN ITALY.

DIMENSIONS
Ø 64x61h cm - Inch Ø 25.2x24h

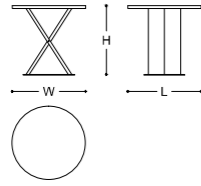

* CODE: 045943 CA809 C1253

FINISHES

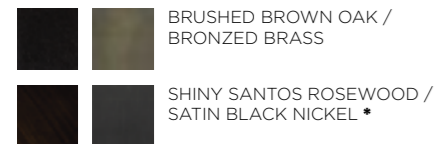

DANZICA

Low table available in rectangular and squared version, made with very thick veneered panels.
MADE IN ITALY.

DIMENSIONS
150x150x30h cm - Inch 59x59x11.8h
140x140x30h cm - Inch 55x55x11.8h
130x130x30h cm - Inch 51.2x51.2x11.8h
130x65x30h cm - Inch 51.2x25.6x11.8h
160x90x30h cm - Inch 63x35.4x11.8h

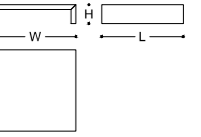

* CODE: 043967 CA862 C0020 (130X130 CM)

FINISHES



ESAGONO

Esagono is a small table/stool with an irregular hexagonal base. It features two curved holes that serve as handles, to make this piece easier to move. Available in Caribbean Lacquer or in solid Canaletto Walnut. The Caribbean Lacquer dresses this range extension with colors inspired by natural environments and tropical islands. MADE IN ITALY.

DIMENSIONS
35x35x39h cm - Inch 13.8x13.8x15.4h

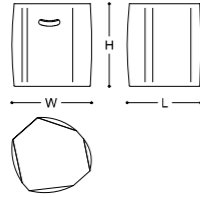

* CODE: 047788 CA918 C4856

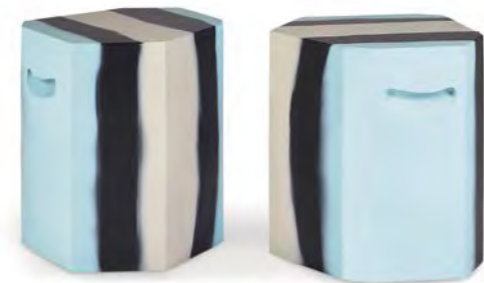

** CODE: 047788 CH205 C9999

FINISHES



CANALETTO WALNUT *

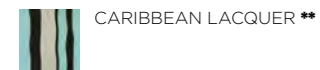

CARIBBEAN LACQUER **

JINGO

Coffee table featuring a precious round top and four legs in solid wood with triangular section. The top is in Emerald Quartzite, a stone showing a delicate hue of green; edges of the top are rounded and polished. MADE IN ITALY.

DIMENSIONS
Ø 120x35h cm - Inch Ø 47.2x13.78h

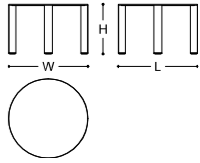

* CODE 049326 CA976 C0086

FINISHES



EMERALD QUARTZITE /
CANALETTO WALNUT *

GALASSIA

Galassia is a set of three squared small tables with different height, so that they can be placed under each other. The thickness of the top and legs is always 4 cm. Galassia small tables can be used in several ways, either placed singularly or together. This set comes in wood, leather or in a very precious finish made in Indonesia: Marine Pen shell, a combination of black and grey shell slices disposed to create a striped square on the top. MADE IN ITALY (Wood and leather versions). MADE IN INDONESIA (Shell version).

DIMENSIONS
 50x50x50h cm - Inch 19.7x19.7x19.7h
 40x40x45h cm - Inch 15.7x15.7x17.7h
 30x30x40h cm - Inch 11.8x11.8x15.7h

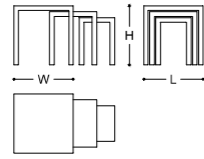

• CODE: 048534 CA975 C1842



** CODE: 048534 CA907 C1654



*** CODE: 048534 CA900 C0074

FINISHES

- BRUSHED BROWN OAK
- BRUSHED GREIGE OAK *
- MARINE PEN SHELL **
- THIN LEATHER ***
(COLOR TO CHOOSE)

LINK

Set of three small tables with rhomboidal shape. The structure features a base and a top element linked by four legs with the same section. The elements can be combined to create different geometric figures. Available in four different versions, featuring wood, metal and leather with shagreen effect print. The colored leather version can be bought as a set of three like all other options but also individually. MADE IN ITALY.

DIMENSIONS
 SINGLE ELEMENT:
 52x30x50h cm - Inch 20.5x11.8x19.7h

HEXAGONAL COMPOSITION:
 69x60x50h cm - Inch 27.1x23.6x19.7h

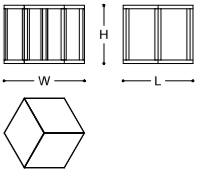

• CODE: 048941 CA772 C4856



** CODE: 048941 CA918 C4856

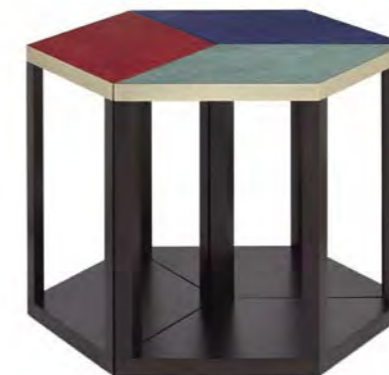

*** CODE: 048941 CA670 C9999

FINISHES

- CANALETTO WALNUT *
- CANALETTO WALNUT / SATIN LIGHT BRASS **
- GREIGE SHAGREEN EFFECT LEATHER / CANALETTO WALNUT
- BLUE/GREEN/RED SHAGREEN EFFECT LEATHER / CANALETTO WALNUT / SATIN LIGHT BRASS ***
-

LARRY

Rectangular small table with light and minimal design. The double structure of the legs with C shape holds the upper shelf, where the drawer is positioned with an almost invisible system that creates a particular suspension effect. Drawer with inside in Canaletto Walnut and metal details in Satin Light Brass.
MADE IN ITALY.

DIMENSIONS
60x45x60h cm - Inch 23.6x17.7x23.6h

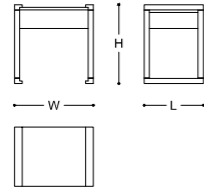

* CODE: 048945 CA963 C4856



** CODE: 048945 CA542 C0086

FINISHES



MELROSE

The Melrose range includes a set of two round coffee tables - that can be bought separately - and a round dining table. The coffee tables feature three legs and a base structure in metal. The curved legs are built directly into the metal profile of the top. The top has a reduced thickness of only 2,2 cm, to highlight the concept of lightness. Available in two different sizes, the Melrose coffee tables can be placed one close to the other and partially overlap.
MADE IN ITALY.

DIMENSIONS
Ø 100x38h cm - Inch Ø 39.4x15h
Ø 68x35h cm - Inch Ø 26.8x13.8h

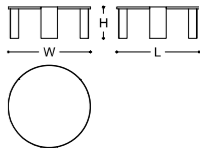

* CODE: 049327 CA417 C0461 (38H CM) / 049328 CA417 C0461 (35H CM)

FINISHES

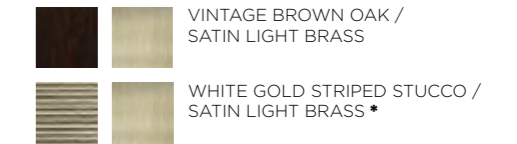

NET

Net is a small squared table with four legs, made by combining cubes of resin and solid walnut. Thanks to the inner reflections and the absolute clarity of the resin, glue in between the cubes is invisible, and the wooden ones literally seem to float in the air. Moreover, the top can be used as a real chessboard since it features 64 squares.
MADE IN ITALY.

DIMENSIONS
40x40x45h cm - Inch 15.7x15.7x17.7h



CODE: 048707 CH993 C8810

FINISHES



NINFEA

Ninfea is a range of coffee tables with methacrylate legs. The thin top is made in Egypt Lacquer, a finish combining different techniques: a yellow metallic paint is applied on a technical fabric and, when it is dry, the fabric is crumpled to crack the paint and create an irregular surface. The fabric is then applied on a panel and coated with a protective transparent lacquer. MADE IN ITALY.

DIMENSIONS
130x130x35h cm - Inch 51.2x51.2x13.8h
130x65x35h cm - Inch 51.2x25.6x13.8h

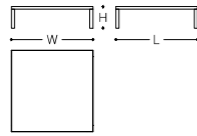

CODE: 048709 CA333 C1363

FINISHES



OTTAWA

Ottawa is a low table characterised by contrasting shapes: a round top and five squared legs. The outer structure is enriched by Jade Shagreen Textured Leather: the texture is reproduced through a printing process followed by a hand-brushing which lightens the color in relief. Metal details are in hand polished Satin Light Brass. MADE IN ITALY.

DIMENSIONS
Ø 70x45h cm - Inch Ø 27.6x17.7h

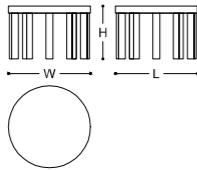

CODE: 043966 CH995 C0086

FINISHES

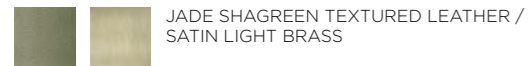

NORIGAMI

Norigami takes inspiration from the idea of a folded sheet of paper transformed into a coffee table. Two identical elements placed closely create the illusion of two bridge tables crossing each other. Norigami is extra thin (2 cm only) and presents a linear design, contrasting with the exclusive finishes in which it is available. Among those, Sky Lacquer is particularly precious since it is entirely hand painted: the inspiration for this material came from the work of the Romantic English painter John Constable (1776 - 1837) and his *Cloud Studies*. Norigami can be purchased individually or as a set of several elements, in order to create different compositions. MADE IN ITALY.

DIMENSIONS
SINGLE PIECE
94x105x30h cm - Inch 37x41.3x11.8h

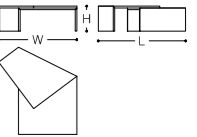

* CODE: 048961 CA013 C2443



** CODE: 048961 CA332 C1432

FINISHES

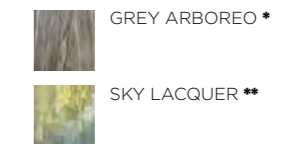

ORESTE

Oreste is a small table with crossed legs. It is available in different versions: the option in Brushed Brown Oak features a tray top that can be chosen squared or rectangular. The base and the tray have to be ordered separately. The chessboard Fair in the Armani/Casa accessories collection is designed to fit into the Oreste tray. Other options of the Oreste table feature, instead, regular tops (not tray) in precious finishes, available with squared top.
MADE IN ITALY.

DIMENSIONS
RECTANGULAR:
80x50x53h cm - Inch 31.5x19.7x20.9h

SQUARED:
60x60x53h cm - Inch 23.6x23.6x20.9h

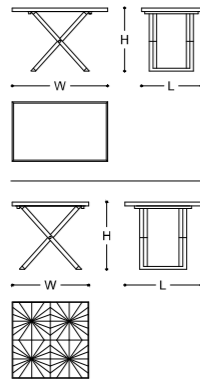

* CODE: 045229 CA336 C0053 (FOLDING BASE) / 045230 CA336 C0053 (TRAY)

FINISHES

WITH TRAY TOP:

BRUSHED BROWN OAK *

WITH FLAT TOP:

BLACK STRAW MARQUETRY /
BLACK BEECH /
SATIN NATURAL BRASS

GREY LIZARD EFFECT LEATHER /
SATIN BLACK NICKEL

SODALITE /
CANALETTO WALNUT /
SATIN LIGHT BRASS **



** CODE: 048077 CA967C 0034

PARIS

Occasional table with bridge shape, marked by its thick veneered panels.
MADE IN ITALY

DIMENSIONS
65x40x60h cm - Inch 25.6x15.7x23.6h

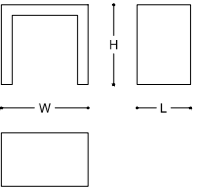

* CODE: 041148 CA867 C0020

FINISHES

BLACK
DRAFTED STUCCO

BLACK MAPLE *

BRUSHED BROWN OAK

MUD DRAFTED STUCCO

WHITE GOLD
DRAFTED STUCCO

PLANK

Plank is a coffee table available in one size only, defined by its rigorous aesthetics reminiscent of Japanese atmospheres. This table emphasizes lightness and horizontality, thanks to its sleek design and wide top. The two versions are both in veneer. The first one presents a structure in Brushed Honey Ashwood, with the top and legs in Crisscross Natural Straw; the second one is entirely in Canaletto Walnut.
MADE IN ITALY.

DIMENSIONS
150x85x35h cm - Inch 59x33.4x13.7h

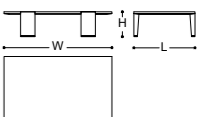

* CODE: 050365 CH035 C0014

FINISHES

BRUSHED HONEY ASHWOOD /
CRISSCROSS NATURAL STRAW *

CANALETTO WALNUT

PLAY

Play is a range of versatile coffee/side tables. As their name suggests, they have been conceived to give you the maximum flexibility: in fact, each structure can be placed using the side you want as base, and it can be completed by adding the top. Bases and top are sold separately, in order to leave the maximum freedom of choice. The structures are entirely made with solid Canaletto Walnut, featuring a special technique for the joints that does not require any metal part. The top is in Black Glass, obtained by painting a smoked tempered glass (thickness of less than 2 cm) on the lower side: the final effect gives the illusion of a shiny black lacquer. MADE IN ITALY.

DIMENSIONS
100x100x60h cm - Inch 39.3x39.3x23.6h

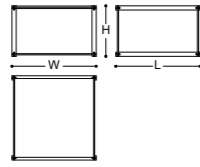

100x100x40h cm - Inch 39.3x39.3x15.7h

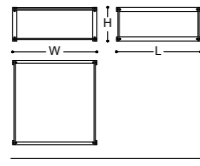

100x40x60h cm - Inch 39.3x15.7x23.6h

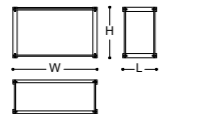

FINISHES

BLACK GLASS / CANALETTO WALNUT

BLACK GLASS / BRUSHED BLACK ASHWOOD



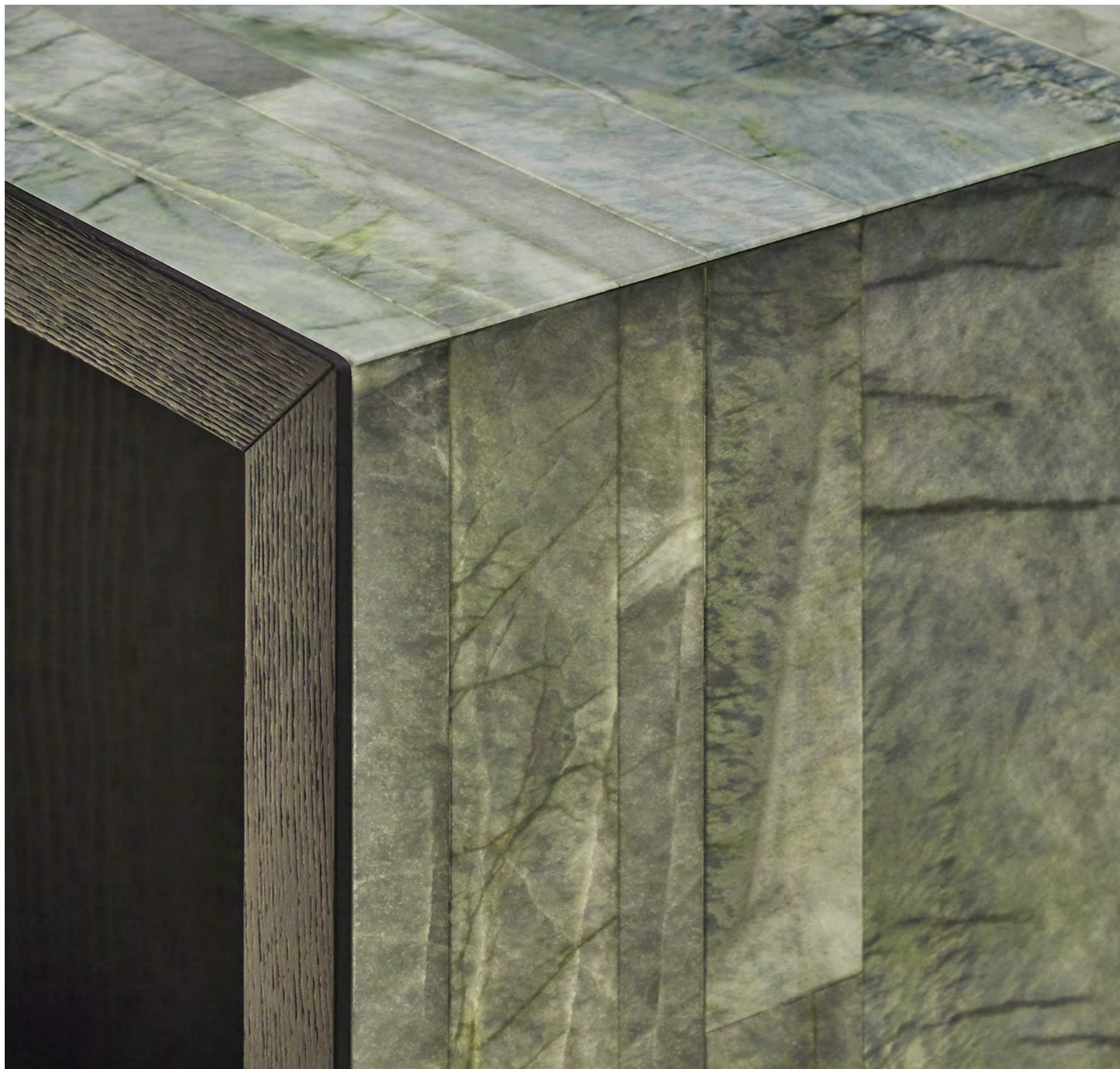

PURO

Puro - "pure" in Italian - is a range that really reflects its name: pure in the shape, pure in the materials. This side table reinterprets the sleek bridge shape typical of Armani/Casa: the timeless design is made precious by the contrast between Canaletto Walnut - Giorgio Armani's favourite wood - and the Kyoto Texture, a finish made with real linen fabric in natural color featuring dark red lacquered inserts. Wood veneer is applied on the inner side and on the border of the top/sides. Puro is available also in a version featuring a wood/stone mosaic: in this case, Puro can show the stone tiles on the inner or the outer side. All corners feature joints at 45°. MADE IN ITALY.

DIMENSIONS
65x40x60h cm - Inch 25.6x15.7x23.6h

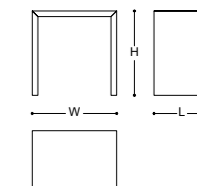





* CODE: 050385 CH045 C8253

* CODE: 050385 CH046 C1785



** CODE: 050385 CH996 C1474

FINISHES

-   BRUSHED BROWN ASHWOOD / EMERALD QUARTZITE *
-   CANALETTO WALNUT / KYOTO TEXTURE **

SAN FRANCISCO

Set of low bridge consoles that can be used as coffee tables, made with very thick veneered panels.
MADE IN ITALY.

DIMENSIONS
100x44x44h cm - Inch 39.4x17.3x17.3h
150x44x44h cm - Inch 59.1x17.3x17.3h
200x44x44h cm - Inch 78.7x17.3x17.3h

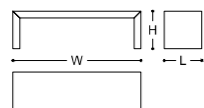

FINISHES

- BLACK DRAFTED STUCCO *
- BLACK MAPLE
- BRUSHED BROWN OAK
- MUD DRAFTED STUCCO
- WHITE GOLD DRAFTED STUCCO



* CODE: 041163 CA862 C0020 (200 CM)

TOMMY

Small G- and A-shaped tables in wood with different finishes.
MADE IN ITALY.

DIMENSIONS
40x40x42.5h cm - Inch 15.7x15.7x16.7h

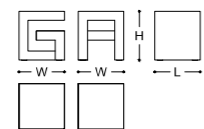

FINISHES

- BLACK LACQUER *
- BROWN LACQUER
- WHITE GOLD DRAFTED STUCCO



* CODE: 044351 CA862 C0020 (LETTER A) / 044352 CA862 C0020 (LETTER G)



CIMAROSA

Round bedside table with x-shaped legs featuring a drawer built into the top frame. The guide rails of the drawers are in wood, to save room inside the drawer. Metal base. MADE IN ITALY.

DIMENSIONS
 Ø 50x50,5h cm - Inch Ø 19.7x19.9h

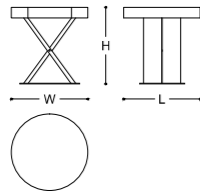

FINISHES

-  BLACK MAPLE / GLOSSY NATURAL BRASS
-  BROWN MAHOGANY / SATIN NATURAL BRASS
-  BROWN TAMO / SMOKED GOLD
-  BRUSHED BROWN OAK / BRONZED BRASS
-  METAL LACQUER / SATIN BLACK NICKEL
-  SHINY SANTOS ROSEWOOD / SATIN BLACK NICKEL *
-  WHITE GOLD LEAF / SATIN NATURAL BRASS



* CODE: 048092 CA809 C1253

DAMASIO

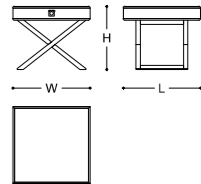

Bedside table with x-shaped legs that support a square storage unit with rounded corners and one drawer. The oak version features legs in solid wood, while the others have legs and top profiles in metal. MADE IN ITALY.

DIMENSIONS
 55x55x45h cm - Inch 21.7x21.7x17.7h



* CODE: 048159 CA885 C0020

FINISHES

-  BLACK STRAW MARQUETRY / SATIN NATURAL BRASS *
-  BROWN MAHOGANY / SATIN NATURAL BRASS
-  BRUSHED BROWN OAK

DAVID 3

The David range of chests of drawers includes also a bedside table, available in two different sizes. MADE IN ITALY.

DIMENSIONS
 52x42,5x44,5h cm - Inch 20.5x16.8x17.6h
 72x42,5x44,5h cm - Inch 28.4x16.8x17.6h

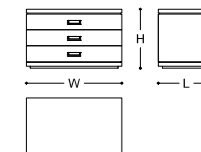

CODE: 048172 CA336 C0053 (52 CM)

FINISHES

-  BRUSHED BROWN OAK

EAST

East is an elegant bridge bedside table with drawer. The drawer features traditional wooden guide rails and is entirely finished with wood.
MADE IN ITALY.

DIMENSIONS
50x50x50h cm - Inch 19.7x19.7x19.7h

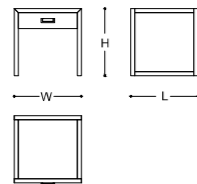

* CODE: 048337 CA881 C0041

FINISHES

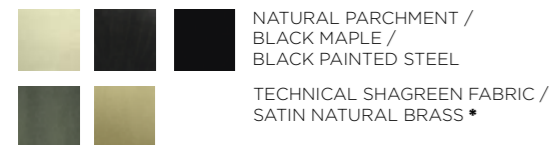

GIO

This bedside table recalls the classic Armani/Casa bridge shape, introducing a circular section. The top is upholstered with Parma technical fabric.
MADE IN ITALY.

DIMENSIONS
Ø 50x50h cm - Inch Ø 19.7x19.7h

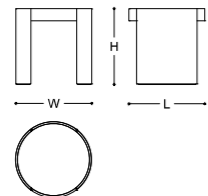

CODE: 048535 CA336 C0053

FINISHES

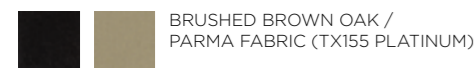

LARRY

Rectangular bedside table with light and minimal design. The double structure of the legs with c-shape holds the upper shelf, where the drawer is positioned with an almost invisible system that creates a particular suspension effect. Drawer with inside in Canaletto Walnut.
MADE IN ITALY.

DIMENSIONS
60x45x50h cm - Inch 23.6x17.7x19.7h

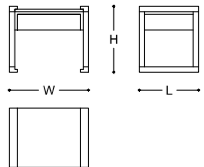

CODE: 048944 CA962 C0460

FINISHES



MENEO

Meneo is a bedside table conceived to match with the Morfeo bed. It features rounded edges and a single extractable shelf moving on a flat slide, refined with a back bar to prevent objects from falling.
MADE IN ITALY.

DIMENSIONS
60x45x45h cm - Inch 23.6x17.7x17.7h

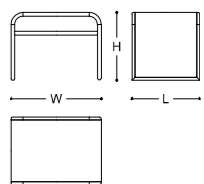

* CODE: 049324 CA899 C9453

FINISHES

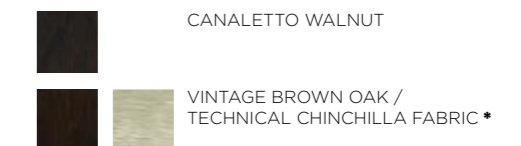

MILTON

Milton is a bedside table conceived to match with the Martin bed. It features a base structure in solid wood with rounded legs. It has one drawer without visible handles, with inner pad in technical fabric. The distinctive trait of this bedside table is given by the legs that reach the top frame with a rounded edge. MADE IN ITALY.

DIMENSIONS
55x45x50h cm - Inch 21.6x17.7x19.7h

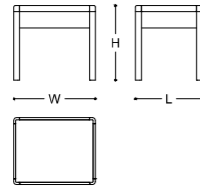

• CODE: 049318 CA975 C1842

FINISHES

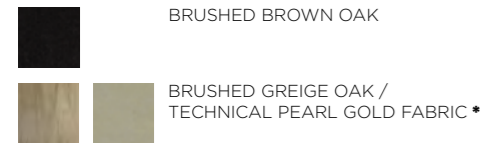

PORTER

Porter is a range of different pieces conceived to complete the living/dining area and the bedroom. All pieces feature some details studied to make the structure look lighter, like the empty spaces in between the doors/drawers and the one that separates the frame from the central part. Porter is available in two versions: the first is in Black Lacquer with drawers front in Rose Silver Leaf, while the second is in Platinum Lacquer with drawers front in Thermo-Treated Paulownia. The latter presents comb joints on the drawers, a particular structural detail left visible to become a decoration as well. Inside, drawers of the first versions are in matt black lacquer, while the second has tone-on-tone drawers. All drawers feature a push-pull opening mechanism. MADE IN ITALY.

DIMENSIONS
63x45x50h cm - Inch 24.8x17.7x19.7h

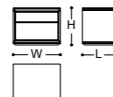

FINISHES



• CODE: 050377 CH052 C0020

RYO

Ryo is a bedside table with rounded corners, conceived to match the sinuous lines of the Ryoko bed. It features a single drawer moving on metal slides. The front of the drawer and the top are clad in thick leather (cuoio) while the structure is made of Canaletto Walnut. MADE IN ITALY.

DIMENSIONS
55x50x50h cm - Inch 21,65x19.7x19.7h

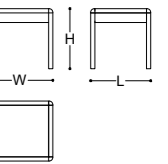

• CODE: 050651 CA900 00151

FINISHES

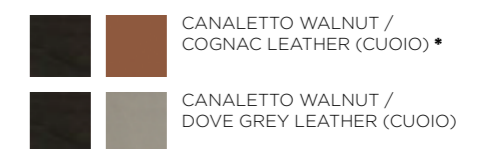

RUSSEL

The Russel range shows a circular top. The tubular structure - covered with thick leather (cuoio) and enriched by metal details - surrounds the top and continues in the legs and the base. The bedside table has one frontal drawer. MADE IN ITALY.

DIMENSIONS WITH DRAWER
 Ø 55x50h cm - Inch Ø 21.65x19.7h

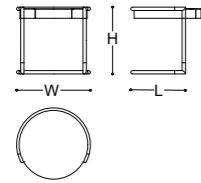

DIMENSIONS WITHOUT DRAWER
 Ø 55x50h cm - Inch Ø 21.65x19.7h

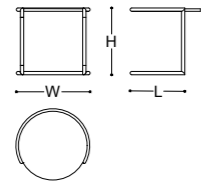

* CODE: 050605 CA900 00151



* CODE: 050630 CA900 00151

FINISHES

- | | | | |
|--|---|---|--|
|  |  |  | CANALETTO WALNUT /
COGNAC LEATHER (CUOIO) /
SATIN LIGHT BRASS * |
|  |  |  | CANALETTO WALNUT /
DOVE GREY LEATHER (CUOIO) /
SATIN LIGHT BRASS |
|  |  |  | HAZELNUT OAK /
CORTECCIA LEATHER (CUOIO) /
SATIN LIGHT BRASS |



BEDS



MORFEO Bed/OTTAWA Bedside tables/DONNA Table lamps



DANDY Bed/CIMAROSA Bedside tables/DONNA Table lamps/TAO Rack/CRONOS Rug

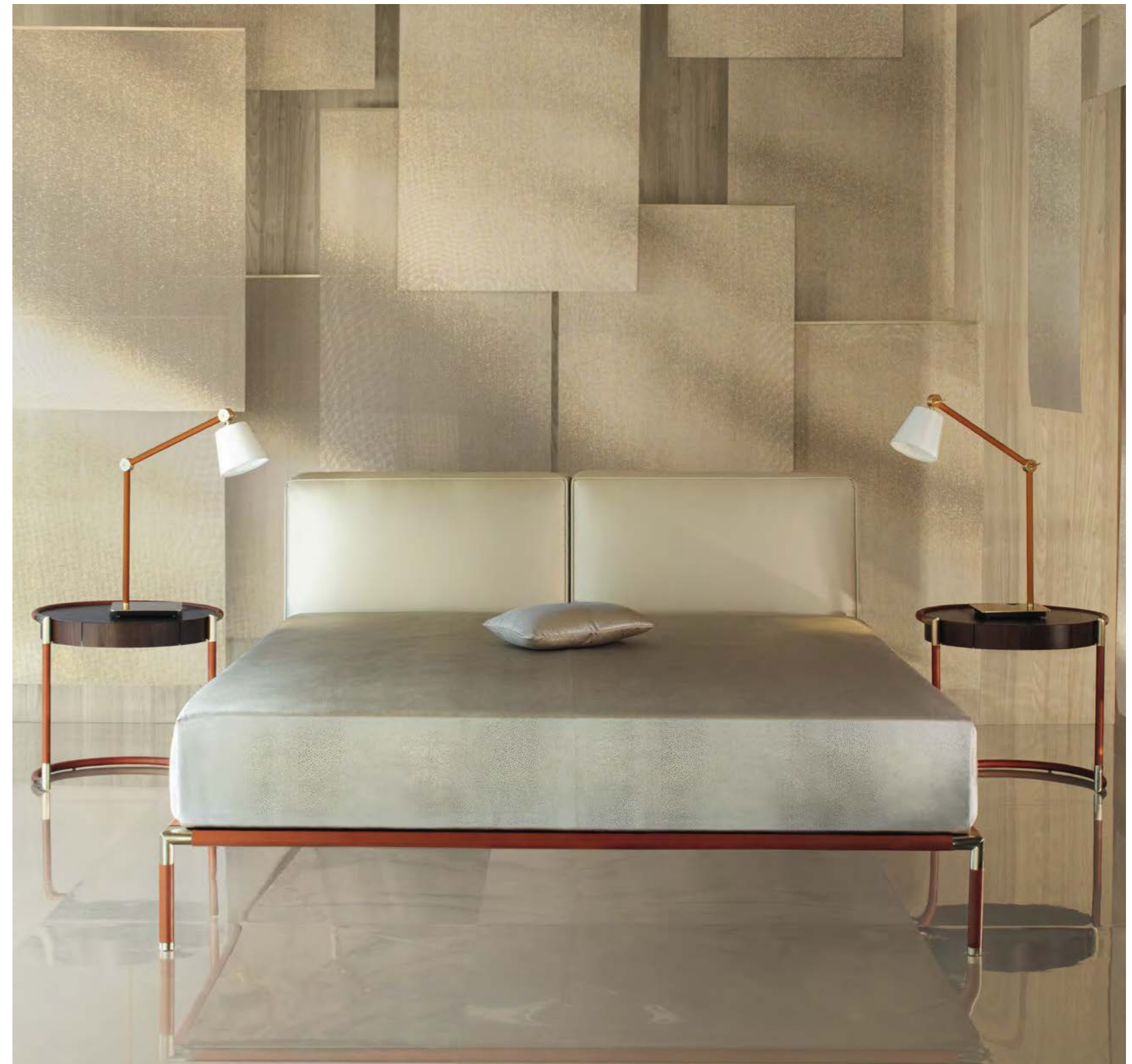

ROLAND Bed/RUSSEL Bedside tables/NEXT Table lamps

DANDY

Bed with completely padded high headboard. The headboard is designed in the shape of an arch rounded in the floor plan view, so that the most external parts are detached from the wall: this feature endows the bedroom interior with lightness and motion and allows the bed to be located centrally in a room. The header comes in two different sizes and must be ordered separately. The sommier is available with or without container. Dandy can be upholstered with all suitable Armani/Casa fabrics (removable) or Soft Touch Leathers in collection. MADE IN ITALY.

DIMENSIONS
BED WITH AND WITHOUT CONTAINER
 MAT. 160 cm
 168x204x30h cm - Inch 66.1x80.3x11.8h

MAT. 70 cm
 178x204x30h cm - Inch 70x80x11.8h

MAT. 180 cm
 188x204x30h cm - Inch 74x80x11.8h

QUEEN USA
 160x207x30h cm - Inch 63x81.5x11.8h

KING USA
 201x207x30h cm - Inch 79.1x81.5x11.8h

SH: 55 cm - Inch 21.7

HEADBOARD
 260x26x110h cm - Inch 102.4x10.2x43.4h
 300x26x110h cm - Inch 118.2x10.2x43.4h

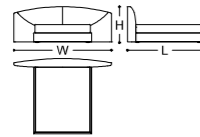

CODE: 048222 CT00x, FABRIC TO CHOOSE / 048142 CT00x, FABRIC TO CHOOSE (MAT. 160 CM)

DREAM

Dream presents a high headboard and a straight sommier frame. Dream is available with flat or bow header. The flat header version can be decorated with a long French roll cushion (to be ordered separately), while the bow header version can be enriched with two additional cushions (to be ordered separately). The header and the extra French roll cushions can be upholstered with all Soft Touch Leathers or suitable Armani/Casa fabrics in collection. MADE IN ITALY.

DIMENSIONS
FLAT HEADER VERSION
 MAT. 160 cm
 164x211x110h cm - Inch 64.6x83.1x43.4h

MAT. 170 cm
 174x211x110h cm - Inch 68.6x83.1x43.4h

MAT. 180 cm
 184x211x110h cm - Inch 72.5x83.1x43.4h

KING USA
 197x214x110h cm - Inch 77.6x84.3x43.4h

QUEEN USA
 156x214x110h cm - Inch 61.5x84.3x43.4h

SH: 50 cm - Inch 19.7

BOW HEADER VERSION
 MAT. 160 cm
 164x211x110h cm - Inchh 64.6x83.1x43.4h

MAT. 170 cm
 174x218x110h cm - Inch 68.6x85.8x43.4h

MAT. 180 cm
 184x218x110h cm - Inch 72.5x85.8x43.4h

KING USA
 197x222x110h cm - Inch 77.6x87.4x43.4h

QUEEN USA
 156x222x110h cm - Inch 61.5x87.4x43.4h

SH: 50 cm - Inch 19.7

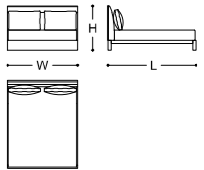

* CODE: 048677 RMA0A ER031 (BOW HEADER, MAT. 170 CM), ROUEN FABRIC

FINISHES

 BROWN MAHOGANY

 BRUSHED BROWN OAK *

MARTIN

Martin is a lifted bed with a slim structure in solid wood. The four feet have a rounded shape that continues also on the header hard structure. The two header cushions are curved like the header itself and feature removable covers. This bed matches with the Milton range of bedside tables. Upholstery of the headboard available in all suitable Armani/Casa fabrics and Soft Touch Leathers in collection.
MADE IN ITALY.

DIMENSIONS

MAT. 160 cm
162x229x100h cm - Inch 63.2x90.1x39.4h

MAT. 170 cm
172x229x100h cm - Inch 67.7x90.1x39.4h

MAT. 180 cm
182x229x100h cm - inch 71.6x90.1x39.4h

KING USA
195x232x100hcm - Inch 76.8x91.3x39.4h

QUEEN USA
154x232x100h cm - Inch 60.6x91.3x39.4h

SH: 50 cm - Inch 19.7

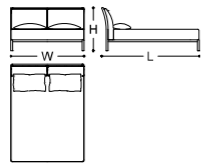

FINISHES

BRUSHED BROWN OAK

BRUSHED GREIGE OAK *



* CODE: 048677 RMA0x, FABRIC TO CHOOSE (BOW HEADER, MAT. 170 CM)

ORIS

Oris is a bed featuring rectangular padded headboard, which is considerably larger than the bedframe. Upholstery available in all suitable fabrics or Soft Touch Leathers in collection; the bedframe is available also in Metallized Dark Green Lacquer. Covers are not removable.
MADE IN ITALY.

DIMENSIONS

MAT. 160 cm
162x201x30h cm - Inch 63.7x79.1x11.8h

MAT. 170 cm
172x201x30h cm - Inch 67.7x79.1x11.8h

MAT. 180 cm
182x201x30h cm - Inch 71.6x79.1x11.8h

QUEEN SIZE USA
154x205x30h cm - Inch 60.6x80.7x11.8h

KING SIZE USA
195x205x30h cm - Inch 76.6x80.7x11.8h

SH: 55 cm - Inch 21.7

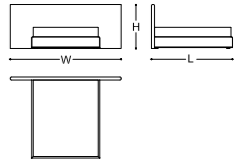

FINISHES

METALLIZED DARK GREEN LACQUER



CODE: 050148 CT00x Txxxx (BEDFRAME 170 CM), FABRIC TO CHOOSE / 050148 CT00x Txxxx (HEADER), FABRIC TO CHOOSE

MORFEO

Morfeo comes from the idea of a floating bed, a concept that becomes reality thanks to the thin, softly curved headboard and footboard. The structure is made of a single metal element, curved at the ends, clad in different fabrics according to the version and outlined with a rounded solid wood frame.

The version in Canaletto Walnut can either be matched with Norfolk fabric, a precious *canneté* interrupted by diagonal lines, available in 9 colors, or with Suva fabric. The design of the latter is inspired by the aerial view of an Asian landscape with rice fields and rivers. All covers are not removable. The Morfeo bed matches with the Meneo bedside tables and shares the same concept of the Onda chaise-longue and the Sharon armchair.

MADE IN ITALY.

DIMENSIONS

MAT. 160 cm
166x236x93h cm - Inch 65.3x93x36.6h

MAT. 170 cm
176x236x93h cm - Inch 69.3x93x36.6h

MAT. 180 cm
186x236x93h cm - inch 73.2x93x36.6h

KING USA
199x239x93h cm - Inch 78.3x94x36.6h

QUEEN USA
158x239x93h cm - Inch 62.2x94x36.6h

SH: 50 cm - Inch 19.7

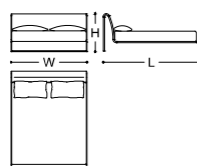

FINISHES

 CANALETTO WALNUT /
NORFOLK FABRIC (ALL COLORS)

 VINTAGE BROWN OAK /
TECHNICAL CHINCHILLA FABRIC *

* CODE: 049320 CA899 C9453 (MAT. 170 CM)



FINISHES

 CANALETTO /
SUVA FABRIC (ALL COLORS) **

** CODE: 045988 NOCOE TX176, SUVA FABRIC (MAT. 170 CM)

ROLAND

Roland is a bed with a tubular hard structure. The tubular elements are covered with thick leather (cuoio) and enriched by metal details with rounded corners on the joints. The tilted header is created by two different cushions, which can be upholstered with all fabrics and Soft Touch Leathers in collection; fabric covers are removable. The bed is available in five different mattress sizes. MADE IN ITALY.

DIMENSIONS

MAT. 160 cm
162x228x90h cm - Inch 63.7x89.7x35.4h

MAT. 170 cm
172x228x90h cm - Inch 67.7x89.7x35.4h

MAT. 180 cm
182x228x90h cm - Inch 71.6x89.7x35.4h



QUEEN SIZE USA
154x233x90h cm - Inch 60.6x91.7x35.4h

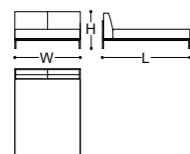

KING SIZE USA
195x233x90h cm - Inch 76.7x91.7x35.4h

SH: 55 cm - Inch 21.7



FINISHES

  COGNAC LEATHER (CUOIO) / SATIN LIGHT BRASS *

  CORTECCIA LEATHER (CUOIO) / SATIN LIGHT BRASS

  DOVE GREY LEATHER (CUOIO) / SATIN LIGHT BRASS

* CODE: 050598 CT00B TR189 (MAT. 170 CM), CANBERRA FABRIC

ROMA

Roma is a bed with upholstered headboard and orthopaedic base with wooden slats. It is available with low or tall headboard. Roma can be upholstered with all Soft Touch Leathers (not removable) or suitable Armani/Casa fabrics (removable) in collection. Wooden feet. MADE IN ITALY.

DIMENSIONS

LOW HEADER VERSION

MAT. 160 cm
164x218x80h cm - Inch 64.5x85.8x31.5h

MAT. 170 cm
174x218x80h cm - Inch 68.5x85.8x31.5h

MAT. 180 cm
184x218x80h cm - Inch 72.4x85.8x31.5h

KING USA
198x222x80h cm - Inch 78x87.4x31.5h

QUEEN USA
157x222x80h cm - Inch 61.8x87.4x31.5h

SH: 47 cm - Inch 18.5

TALL HEADER VERSION

MAT. 160 cm
164x218x110h cm - Inch 64.5x85.8x43.3h

MAT. 170 cm
174x218x110h cm - Inch 68.5x85.8x43.3h

MAT. 180 cm
184x218x110h cm - Inch 72.4x85.8x43.3h

KING USA
198x222x110h cm - Inch 78x87.4x43.3h

QUEEN USA
157x222x110h cm - Inch 61.8x87.4x43.3h

SH: 47 cm - Inch 18.5

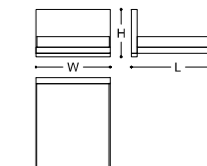

FINISHES

 BRUSHED BROWN OAK *

 CANALETTO WALNUT

* CODE: 048684 RMA0C TR710 (MAT. 170 CM), HAVANA FABRIC



RYOKO

Entirely upholstered bed with invisibile feet that, together with the slightly tilted sides of the bedframe, make the bed look suspended (feet and bedframe are 10 cm and 15 cm high respectively). All edges present a fabric piping. Available in all fabrics and Soft Touch Leathers in collection; fabric covers are removable. The bed is available in five different mattress sizes.
MADE IN ITALY.

DIMENSIONS

MAT. 160 cm
162x221x90h cm - Inch 63.7x87x35.4h

MAT. 170 cm
172x221x90h cm - Inch 67.7x87x35.4h

MAT. 180 cm
182x221x90h cm - Inch 71.6x87x35.4h

QUEEN SIZE USA
154x224x90h cm - Inch 60.6x88.1x35.4h

KING SIZE USA
195x224x90h cm - Inch 76.7x88.1x35.4h

SH: 55 cm - Inch 21.7

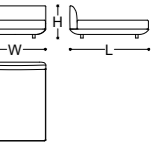

CODE: 050593 CT00D TX039 (MAT. 170 CM), NOTO FABRIC

GARCIA

Classic hypoallergenic mattress in latex of superior quality, h. 25 cm.

Springs

Independent spring system Supermicro 3000 h. 140 mm, 7 different comfort zones, spring section of 0.9/1.0 mm.

Density

1100 springs/m².

Frame

Perimeter box in high-density expanded polyurethane.

Layers

Upper and lower layer in Latex with passing-through holes h. 40 mm.

Upholstery

Removable outer cover with perimeter borders and zips on both sides.

Padding

Anallergic wadding 300 gr/m².

Fabric

Jacquard fabric with Armani/Casa logo.



GIAVA

Super comfort quality mattress in memory foam, h. 25 cm.

Springs

Independent spring system Supermicro 3000 h. 140 mm, 7 different comfort zones, spring section of 0.9/1.0 mm.

Density

1100 springs/m².

Frame

Perimeter box in high-density expanded polyurethane.

Layers

Upper and lower layer in Memory Foam h. 40 mm.

Upholstery

Removable outer cover with perimeter borders and zips on both sides.

Padding

Anallergic wadding 300 gr/m².

Fabric

Jacquard fabric with Armani/Casa logo.



GARLAND

High-quality mattress with double thickness: the main body with springs and a thinner additional mattress on top filled with natural feathers. h. 27 cm.

BASE MATTRESS

Springs

Independent spring system Micropocket h. 140 mm with 7 different comfort zones, spring section of 1.1/1.2 mm.

Density

600 springs/m².

Frame

Perimeter box in high-density expanded polyurethane.

Layers

Upper and lower layer in pyramid polyurethane foam Firm Support h. 30 mm.

Upholstery

Non-removable outer cover with perimeter borders.

Padding

Anallergic wadding 300 gr/m².

Fabric

Jacquard fabric with Armani/Casa logo.

TOP PILLOW

Upholstery

Removable outer cover with perimeter borders.

Padding

Anallergic wadding 300 gr/m².

Fabric

Jacquard fabric with Armani/Casa logo.

Inner thin mattress padded with goose feathers, tied to the main mattress thanks to leatherette straps FastStrap® system (trademark).





SLAT STRUCTURES

All Armani/Casa beds include a double bed slat structure with a wooden or steel frame. The frame can be structural (so the whole slat structure cannot be separated from the bed) or removable (the whole slat structure can be separated from the bed).

All types comprise a system with flexible slats in beech wood. Depending on the range, each bed features a different variant of this system:

- **Basic slats:** flexible slats with no additional options;
- **Shock-absorbing slats:** each slat lies on a flexible rubber support, which adapts the slat itself depending on the weight above;
- **Adjustable slats:** double slats kept together by a couple of adjustable plastic rings. The farther the rings on the same slat are, the more the slat becomes rigid;

		BASIC SLATS	SHOCK-ABSORBING SLATS	ADJUSTABLE SLATS
STRUCTURAL FRAME	STEEL	DREAM MARTIN ROLAND		MORFEO RYOKO
	WOOD			
REMOVABLE FRAME	STEEL	ROMA	DANDY ORIS	

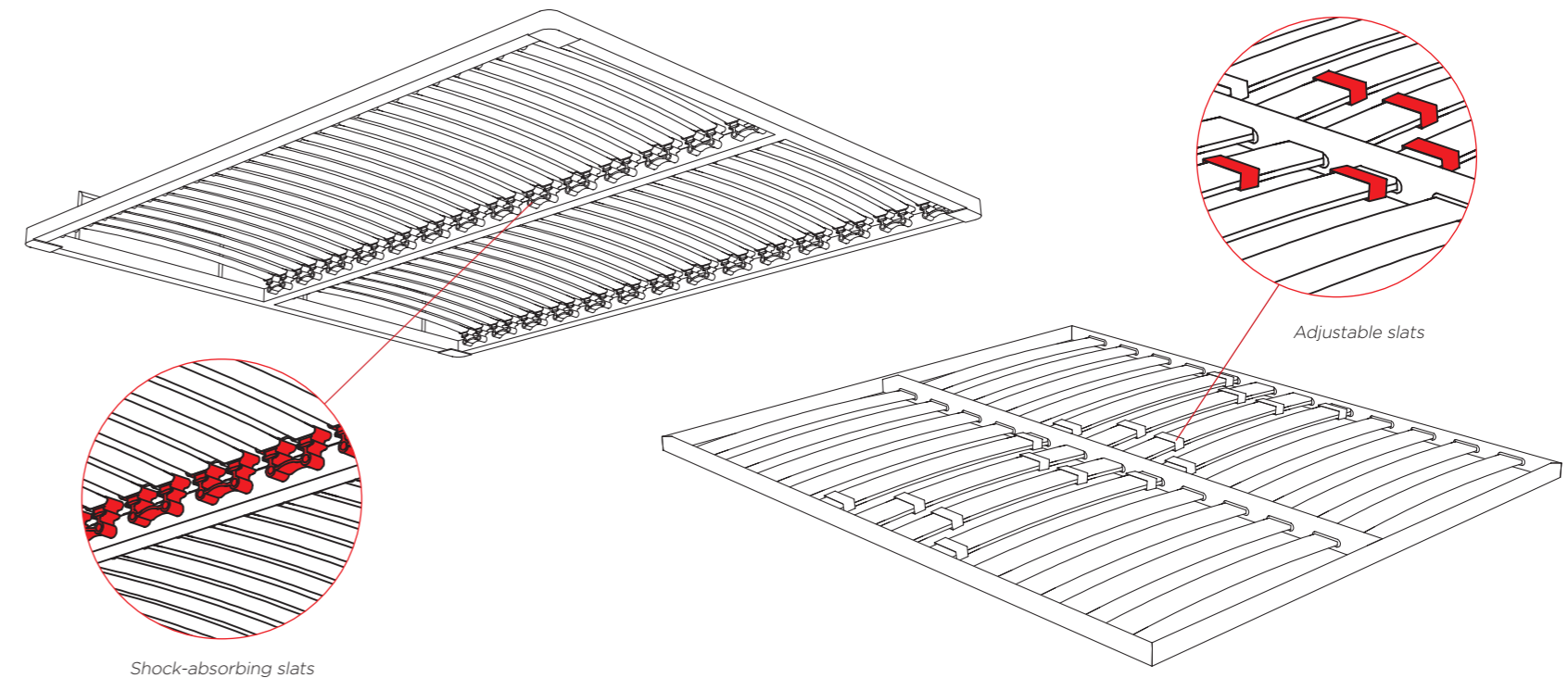

DESKS



OLIVIA Desk/CLASSIC Chair/NEMA Floor lamp

CAMILLA

Writing desk with Art Déco inspiration. The rigorous lines of Camilla mix metal with shiny wood or thick Tuscanian leather (cuoio) to achieve a look marked by a timeless elegance. MADE IN ITALY.

DIMENSIONS
133x66,5x75h cm - Inch 54.4x26.2x29.5h

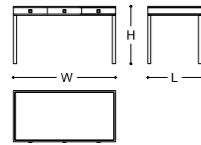

* CODE: 048048 CA867 C0020

FINISHES

-   BLACK MAPLE / GLOSSY NATURAL BRASS *
-   DOVE GREY LEATHER (CUOIO) / SATIN BLACK NICKEL **
-   SHINY SANTOS ROSEWOOD / SATIN BLACK NICKEL



** CODE: 048048 CA185 C0554

EUCLIDE

Euclide has a light look, thanks to its thin top and chests of drawers supported by only two metal ribbon legs. Euclide is designed to be used from both sides, since it has four drawers with traditional guide rails on each side. This desk is equally suitable for being used in a study or in a bedroom. The frames of the drawers are in solid wood. MADE IN ITALY.

DIMENSIONS
150x70x75h cm - Inch 59.1x27.6x29.5h

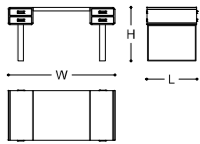

CODE: 048276 CA867 C0020

FINISHES

-  BLACK MAPLE / PAINTED STEEL





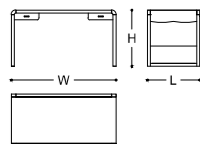

JOLIE

Featuring minimal lines with hints of the Thirties, Jolie is a two-drawer desk with wooden structure and leather top. It is equipped on each side with pockets conceived to store paper and magazines. Underneath the worktop two drawers open with the aid of a small leather handle with metal GA logo detail. The drawers feature wooden guide rails, which allow more height to the inside of the drawer. The drawer fronts show refined visible stitching. Jolie has no back panel, but the solid wood structure is conceived to ensure optimal stability. MADE IN ITALY.

DIMENSIONS
140x70x75h cm - Inch 55.1x27.5x29.5h



FINISHES

-  Frame BROWN ELM
-  BLACK LEATHER (CUOIO)
-  CORTECCIA BROWN LEATHER (CUOIO)
-  DARK BROWN LEATHER (CUOIO)
-  DARK GREEN LEATHER * (CUOIO)
-  DOVE GREY LEATHER (CUOIO)



* CODE: 048873 CA920 C4858

OLIVIA

Olivia is a desk reinterpreting the iconic bridge shape through a slightly curved top: its reduced dimensions make it suitable also to be used as a vanity table. Olivia features a hole for cables and a single central drawer. The minimalistic design is presented in wood or in combinations of very rich materials, like shells. The legs of those precious versions are in Platinum Lacquer, and their outer side is carved to obtain an undulate surface. MADE IN ITALY.

DIMENSIONS
136x66x75h cm - Inch 53.5x25.9x29.5h

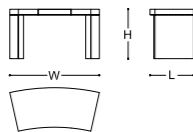

* CODE: 050102 CH999 C2254



** CODE: 050102 CA509 C0884

FINISHES

-  BLACK LARCH / SATIN LIGHT BRASS
-  CANALETTO WALNUT / SATIN LIGHT BRASS
-  GREEN SPOTTED SHELL / PLATINUM LACQUER / SATIN LIGHT BRASS **
-  SHELL MOSAIC / PLATINUM LACQUER *

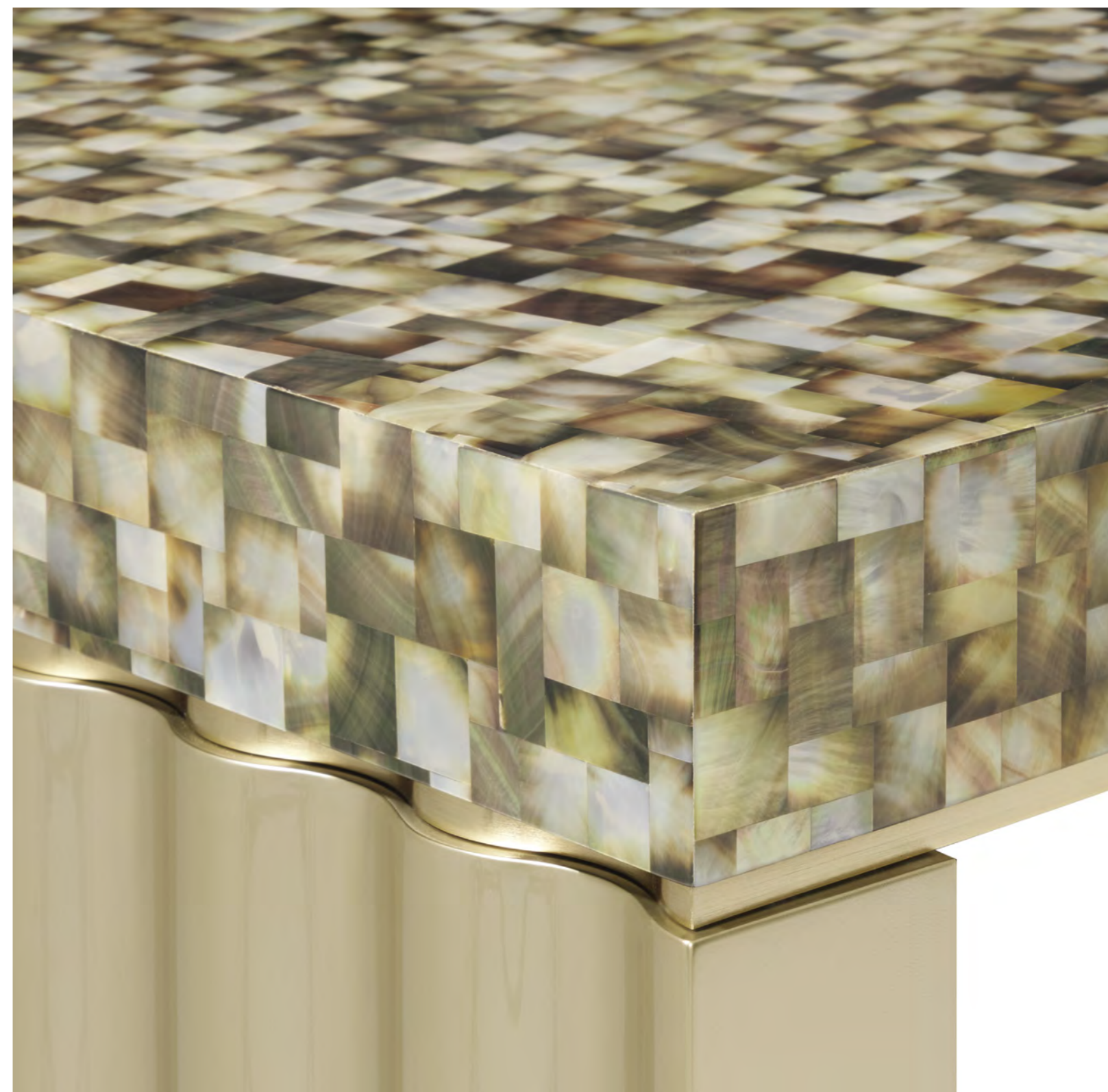



ROUSSEAU

This elegant sleek desk presents the same features of the Olimpia bookcase and the Prestige sideboard: tubular elements clad in thick leather (cuoio) are connected by metal ribbons in brass, becoming decorative and functional details at the same time. Rousseau enhances the concept of lightness thanks to its thin top (frontal edge of 27 mm) and the legs completed by metal feet. The desk is equipped with four drawers. A particularly rich version features top and sides in hand-polished brass; on this version, top and sides are made out of a single metal piece. A desk pad in thick leather (cuoio) with embossed logo can be bought separately and was conceived to increase comfort while working on the desk. **MADE IN ITALY.**

DIMENSIONS
150x65x75h cm - Inch 59x25.5x29.5h

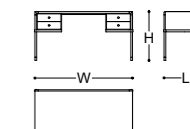

* CODE: 050602 CA900 00151



** CODE: 050602 CA426 C0052

FINISHES

Wood versions

- | | | | |
|--|--|--|--|
| | | | CANALETTO WALNUT / DOVE GREY LEATHER (CUOIO) / SATIN LIGHT BRASS |
| | | | CANALETTO WALNUT / COGNAC LEATHER (CUOIO) / SATIN LIGHT BRASS * |
| | | | HAZELNUT OAK / CORTECCIA LEATHER (CUOIO) / SATIN LIGHT BRASS |

Metal version

- | | | | |
|--|--|--|--|
| | | | SATIN LIGHT BRASS / COGNAC LEATHER (CUOIO) / CANALETTO WALNUT ** |
|--|--|--|--|

STENDHAL

The Stendhal secretary desk, marked by a strong *Art Déco* inspiration, is clad in the Jade Shagreen Textured Leather: the texture is reproduced through a printing process followed by a hand-brushing which lightens the color in relief. Inner structure in Canaletto Walnut, with handles, feet and cable hole in Satin Light Brass. An important technical feature is the opening system of the folding top: through a special clutch device with an exposed steel wire, the top opens slowly without dropping and keeps its stability when working on it. Stendhal features an inner LED lighting system, with a switch button located under the shelf. **MADE IN ITALY.**

DIMENSIONS
120x51x123h cm - Inch 47.2x20.1x48.4h

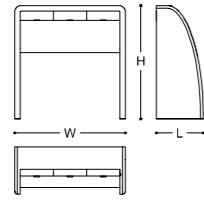

FINISHES



CODE: 050768 CH995 C0086



CABINETS
AND
BOOKCASES

- BAR CABINETS
- BOOKCASES
- CHESTS OF DRAWERS
- MULTIFUNCTIONAL CABINETS





RIESLING Bar cabinet/ORESTE Small tables



MIRÒ Buffet/JINGO Coffee table/NOLAN Sofa/NOIR Rug

CIRCLE

Circle is a range of revolving tables, conceived to store barware, available in two sizes. The large version features two curved doors and two pull-out drawers. The inside of the doors is equipped with a structure to hold stem glasses, while the drawers can be used to store bottles. The small but taller version opens with the aid of a slim metal handle, and the inside of the curved doors is equipped with two shelves. Circle takes its inspiration from the travel furniture typical of the 20s and the 30s, object-sculptures that were transformable and suggesting several functions. The cabinet, thanks to a fixed turning base, can rotate of 360°. MADE IN ITALY.

DIMENSIONS

LARGE: Ø 81x53h cm - Inch Ø 31.9x20h

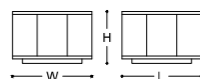

SMALL: Ø 50x65h cm - Inch Ø 19.7x25.6h

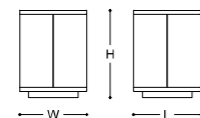

FINISHES

BLACK DRAFTED STUCCO *

SHINY SANTOS ROSEWOOD (LARGE VERSION ONLY)

* CODE: 048066 CA862 C0020



FINISHES

WHITE GOLD DRAFTED STUCCO **

** CODE: 048067 CA863 C0461

CLUB

One of the most iconic cocktail cabinet by Armani/Casa, Club takes inspiration from vintage travel furniture thanks to its x-shaped legs. This cocktail cabinet features container doors for the storage of glasses. The outer shell of the red version is marked by Lacquered Red Linen: a finish featuring real linen fabric coupled with gold leaf and then painted in red, where a layer of transparent lacquer adds the final shiny touch leaving the textured surface visible. Inside, the beautiful Singapore fabric - marked by the design of Japanese-inspired fans - creates an unexpected contrast with the outside. Metal details are in hand-polished Satin Light Brass, while legs are in Canaletto Walnut. The interior holds a lower pull-out shelf covered by an extralight transparent tempered glass (5 mm thick) for the preparation of drinks and a foldout top. A single lower unit, opened thanks to a push-pull system, hosts a small drawer conceived to store cocktail utensils. The other version, instead, features interior in bronze lacquer with a lower pull-out shelf in technical fabric top covered by an extralight transparent tempered glass (5 mm thick) for the preparation of drinks, a fold-out top for service and three lacquered drawers: one for cocktail utensils, one to store the ice bucket and the last for bottles.

MADE IN ITALY.

DIMENSIONS
79x61x130h cm - Inch 31.1x24x51.2h

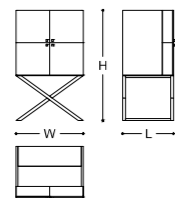

* CODE: 048358 CA880 C1043



** CODE: 048075 CH998 C0074



FINISHES



RIESLING

Bar cabinet marked by a large storing unit that lies on a thin linear structure. Riesling is available in different precious finishes that enrich the neat design. The back of the doors is equipped with short shelves conceived to store glassware. The squared tiles on the doors of the Brushed Greige Oak version are covered by tempered extra-clear glass. The version in Moonlight Decoration features a tubular structure in metal, while others have legs with squared section. The version in Hazelnut Midollino presents handles in bioresin and interiors covered in Cognac leather. MADE IN ITALY.

DIMENSIONS
76x57x154h cm - Inch 30x22.4x60,6h

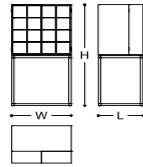

FINISHES

			BRASS CARVED LIQUID METAL / CANALETTO WALNUT / SATIN LIGHT BRASS *
			BRUSHED GREIGE OAK / BLACK LACQUER / SATIN LIGHT BRASS **
			CARVED WALNUT / SMOKED GOLD ***

FINISHES

			MOONLIGHT DECORATION / BLACK LACQUER / TECHNICAL PEARL GOLD FABRIC *
			TECHNICAL SHAGREEN FABRIC / SMOKED GOLD **
			HAZELNUT MIDOLLINO / OLIVE / SATIN LIGHT BRASS / COGNAC LEATHER (CUOIO) ***



* CODE: 048069 CA961 C2456



** CODE: 048069 CA975 C1842



*** CODE: 048069 CA822 C9553



* CODE: 048069 CA668 C0020

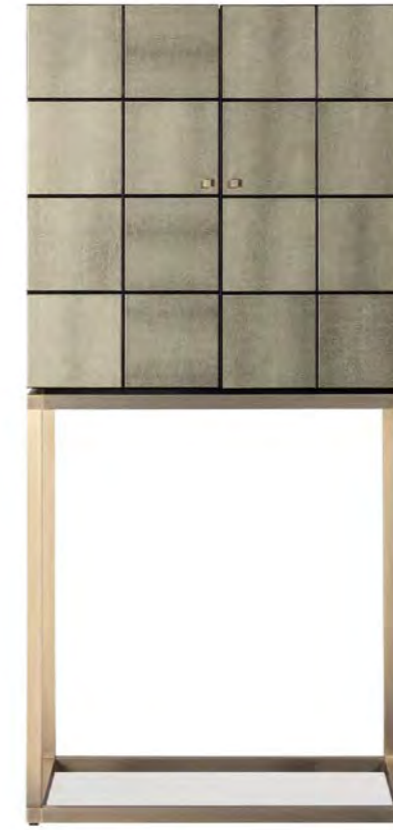

** CODE: 048069 CA956 C0041



*** CODE: 048069 CH225 C3555

MUSA

Musa stands out for its light and essential design, yet enriched by unexpected details. The whole structure is modular, offering the opportunity of create more than just two columns. Each shelf is marked by two exclusive metal details with a particular shape, so that the shelves look hooked to the wooden structure. Pads in Dark Green Leather. The vertical distance in between the shelves is 40 cm. Metal feet keep the structure lifted from the ground. MADE IN ITALY.

DIMENSIONS
2 columns:
169x40x177h cm - Inch 66.5x15.75x69.7h

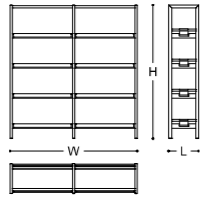

FINISHES



ONYX

Onyx is a fixed bookcase that reinterprets the shape of the Matrix and the Nathan ranges (consoles, small tables, dining table) introduced in the last years: the metal structure features the same extra thin look (1 cm - Inch 0.4) and the iconic triangular section, which creates particular reflections. The top part of the shelves and the sides present the same material, contrasting with the structure always in Satin Light Brass. Available in different sizes (57, 95 and 180 cm of height) and materials. MADE IN ITALY.

DIMENSIONS
180x40x57h cm - Inch 70.8x15.7x22.4h
180x40x95h cm - Inch 70.8x15.7x38.5h
180x40x180h cm - Inch 70.8x15.7x70.8h

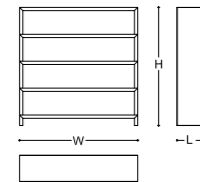

FINISHES

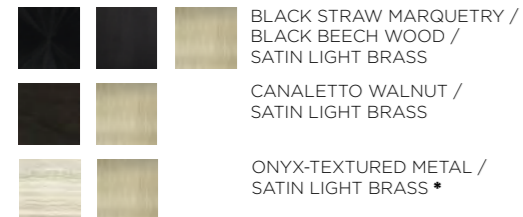

* CODE: 050118 CA635 C2110

OLIMPIA

The free-standing Olimpia bookcase is made of a rectangular wooden frame hosting three shelves. This structure is sustained - and lifted from the ground - by five vertical tubular bars covered with leather, whose asymmetrical disposition gives movement to the entire piece. Stripes of metal, similar to ribbons, have the double function of carrying the shelves and giving more stability to the entire bookcase. MADE IN ITALY.

DIMENSIONS
200x40x175h cm - Inch 78.7x15.7x68.8h

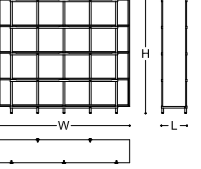

* CODE: 050119 CA636 C4455



** CODE: 050119 CA941 C4856

FINISHES

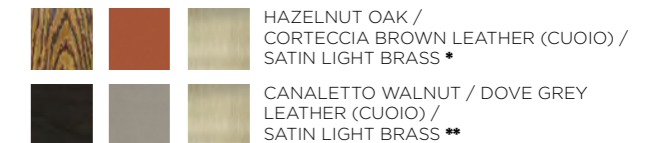

CASTILLA

Chest of drawers available in two sizes, with a central straight element and rounded sides. The six external drawers are easily accessible thanks to a special rotating system. All versions have Black Maple and glossy bronze shagreen-printed leather inside the drawers. Metal handles for all versions.
MADE IN ITALY.

DIMENSIONS
TALL:
155x45x80h cm - Inch 61x17.7x31.5h

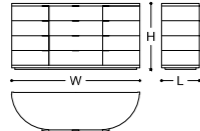

LOW:
220x45x62h cm - Inch 86.6x17.7x24.4h

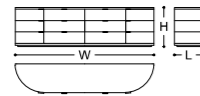

* CODE: 048059 CA803 C0617

FINISHES



** CODE: 048060 CA867 C0020

DAMOCLE

Wooden dresser with ribbon metal legs. The central part comprises a single compartment with two doors and a central shelf. A cable hole is located at the back to allow the installation of hi-fi appliances (blu-ray, dvd, gaming console) to use of this product also as a TV unit. The two outer parts have three drawers that open with the aid of metal handles.
MADE IN ITALY.

DIMENSIONS
216x50x75h cm - Inch 85.1x19.7x29.6h

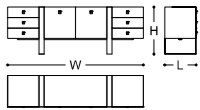

* CODE: 048114 CA832 C0373

FINISHES

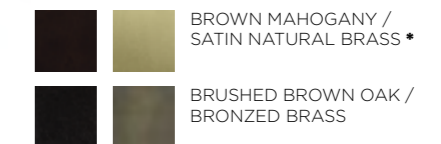

DAVID

The David range includes different storage units with drawers: a buffet (five central drawers and two columns of mock drawers hiding two doors) and a low chest of drawers (five large drawers). An internal extra moving shelf is available for the buffet option. MADE IN ITALY.

DIMENSIONS
BUFFET
 180x52x83,5h cm - Inch 70.9x20.4x32.9h

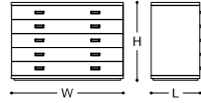

CHEST OF DRAWERS
 120x52x83,5h cm - Inch 47.2x20.4x32.9h



FINISHES

 BRUSHED BROWN OAK /
 BRONZED BRASS



CODE: 048197 CA336 C0053

PORTER

Porter is a range of different pieces conceived to complete the living/dining area and the bedroom. All pieces feature some details studied to make the structure look lighter, like the empty spaces in between the doors/drawers and the one that separates the frame from the central part. Porter is available in two versions: the first is in Black Lacquer with drawers front in Rose Silver Leaf, while the second is in Platinum Lacquer with drawers front in Thermo-Treated Paulownia. The latter presents comb joints on the drawers, a particular structural detail left visible to become a decoration as well. Inside, drawers of the first versions are in matt black lacquer, while the second has tone-on-tone drawers. All drawers feature a sh-pull opening mechanism. MADE IN ITALY.

DIMENSIONS
UR-DRAWER VERSION
 x45x50h cm - Inch 48x17.7x19.6h

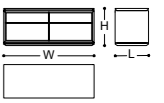

-DRAWER VERSION
 x45x50h cm - Inch 70.8x17.7x19.6h

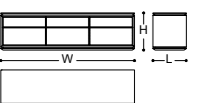

* CODE: 050375 CH052 C0020



** CODE: 050375 CA779 C0161

FINISHES

 BLACK LACQUER /
 ROSE SILVER LEAF *
 PLATINUM LACQUER /
 THERMO-TREATED PAULOWNIA **
 CANALETTO WALNUT

SMART

Smart is a range of pieces matching the already existing Matrix - Mirò - Nathan - Onyx ranges. All these products share the same concept: a bridge-shaped base structure in metal featuring a triangular section, which creates a particular effect thanks to the reflection of light. All Smart pieces are equipped with container units in wood, hosting a different number of drawers. MADE IN ITALY.

DIMENSIONS
95x45x115h cm - Inch 37.4x17.7x45.3h

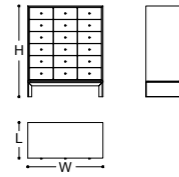

CODE: 050738 CA918 C4856

FINISHES



EXCELSIOR

Excelsior is a storing unit with a vertical row of five drawers and a door with ten mock drawers, containing two shelves. The structure lies on a tubular metal base like the Riesling range. The use of precious materials makes this piece of furniture highly decorative. Inside, Excelsior is covered with glossy dark grey lacquer, while the bottom of the shelves and drawers are lined with bronze technical fabric. MADE IN ITALY.

DIMENSIONS
72,5x44x150h cm - Inch 28.5x17.3x59.1h

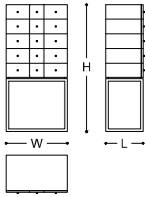

CODE: 048309 CA871 C0020

FINISHES

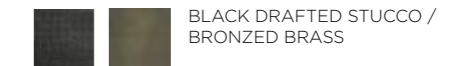

GABRIEL

Gabriel is a wardrobe characterized by its curved shape, which recalls the vintage trunk style. The internal compartments of the wardrobe are upholstered with fabric and can be equipped according to the need of the client. The inner side of both doors features a mirror. This wardrobe is refined with a LED lighting system with warm tones (3600k). The lights turn on automatically thanks to several detectors placed in different compartments. MADE IN ITALY.

DIMENSIONS
210x66x237,5h cm - Inch 82.7x26x93.5h

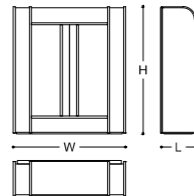

CODE: 048544 CA916 C9553

FINISHES



MIRÒ

Buffet with three doors. The main unit of this buffet lies on a metal bridge structure with triangular section, like the one of the Matrix set of consoles. Doors feature a metal profile and push-pull opening system with slowing device; the first two doors from the left close a unique storing unit, while the last one closes a separate compartment. A middle shelf is featured in both parts. Mirò is available in two versions, with or without automatic inner lighting LED systems. MADE IN ITALY.

DIMENSIONS
THREE DOOR VERSION
160x45x75h cm - Inch 63x17.7x29.5h

FOUR DOOR VERSION
180x45x75h cm - Inch 70.8x17.7x29.5h

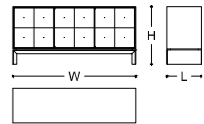

*CODE: 049332 CA977 C1941 (WITH LED SYSTEM)



** CODE: 045986 CA417 C0461 (WITH LED SYSTEM)

FINISHES



PRESTIGE

Prestige is a sideboard developed to match the Olimpia bookcase. Like Olimpia, the structure is sustained - and lifted from the ground - by vertical tubular bars covered with leather, whose asymmetrical disposition gives movement to the entire piece. A stripe of metal, similar to a ribbon, has the double function of carrying the container unit and giving more stability to the entire sideboard. The outer frame shows joints at 45°, and is separated from the central body by an empty space to add lightness to the whole piece. The 4 doors can be opened thanks to metal knobs. Prestige is available in the same finishes of the Olimpia bookcase. MADE IN ITALY.

DIMENSIONS
180x45x78h cm - Inch 70.8x17.7x30.7h

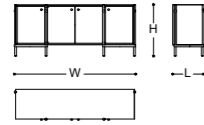

* CODE: 050381 CA941 C4856



FINISHES

- CANALETTO WALNUT / DOVE GREY LEATHER (CUOIO) / SATIN LIGHT BRASS *
- HAZELNUT OAK / CORTECCIA BROWN LEATHER (CUOIO) / SATIN LIGHT BRASS



SUITE

Suite is a mute servant cabinet: this classic piece becomes a luxury treasure chest equipped with all that is needed to host clothes, shoes and other accessories like hats, ties, scarves and much more. The outside is in Carved Paulownia, whose natural warm color is emphasized by the three-dimensional surface recalling the iconic *canneté* texture typical of the Armani aesthetics. Plain paulownia inserts enrich the sleek look of the doors, hosting a lock with GA-shaped keys. Inside, Ivory Soft Touch Leather adds a touch of luster with its grained appearance. Suite is equipped with several hooks, foldable shelves, a full-height mirror and a compartment for hats (left side), a lower container for shoes (center), pockets, small objects containers, clothes hangers, a foldable stool, a round extendable mirror with magnifying glass, a brush and a shoe horn (right side). Suite hosts an inner LED illuminating system located in the upper part of the central unit, that automatically switches on after opening the doors.

MADE IN ITALY.

DIMENSIONS
86x46x155h cm - Inch 33.8x18.1x61h

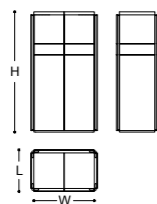

FINISHES

CARVED PAULOWNIA /
IVORY SOFT TOUCH LEATHER /
SATIN LIGHT BRASS

CODE: 050760 CH964 C0253

OCCASIONAL

- COIFFEUSES
- RACKS
- MIRRORS
- SCREENS



ANTOINETTE

The Antoinette iconic vanity table is characterized by a cylindrical shape with folding top and hidden seat. The version in Patinated Linen and wood creates a beautiful combination with the internal parts in acrylic inspired by natural mother-of-pearl. The seat is upholstered with Havana fabric. The other version, instead, is marked by Jade Shagreen Textured Leather: the texture is reproduced through a printing process followed by a hand-brushing which lightens the color in relief. The inner structure is in acrylic, inspired by natural mother-of-pearl, and Dark Green Lacquer. The seat is upholstered with Stockholm fabric, featuring a shiny/matt checkered motif. This version features a backlit round mirror with a central switch button. MADE IN ITALY.

DIMENSIONS

CLOSED: Ø 70x89,5h cm - Inch Ø 27.5x35.2h

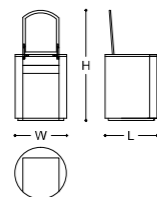

FINISHES

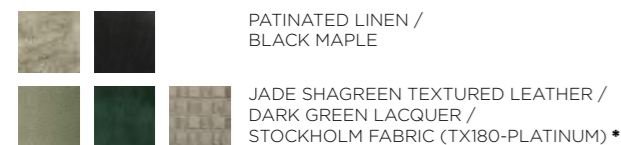

* CODE: 045609 CH995 C0086

GLAM

Glam is a coiffeuse with a simple but functional design. Its large top features curved sides and a metal outline, plus three drawers with the standard Armani/Casa handle. The top is supported by two tubular metal legs with squared section. A round mirror (diam. 40 cm) is fixed on the top and can rotate on both axes (up/down, left/right). The mirror is backlit through a LED system around the glass, that can be switched on/off thanks to a button positioned on the back. The matching stool is sold separately. MADE IN ITALY.

DIMENSIONS

COIFFEUSE
120x50x123h cm - Inch 47.2x19.7x48.4h

STOOL

60x40x45h cm - Inch 23.6x15.7x17.7h

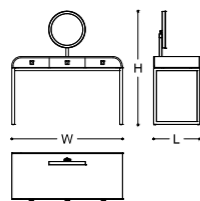

FINISHES



CODE: 048545 CA910 TX155 (COIFFEUSE) / 048546 CT00A TX155 (STOOL)

PASSION

Coiffeuse. Passion represents the latest addition to the collection of vanity tables by Armani/Casa. Born from the reinterpretation of the iconic Giunone desk, this coiffeuse is marked by sinuous lines perfectly matching the delicate hues of green of the materials: the leather-clad structure is completed by a top in natural quartzite and detail in satin-finished brass. The coiffeuse features 8 drawers with matt black interiors in wood, which can be used to store jewelry, perfumes and make-up, but also stationery and writing instruments. The matching stool is sold separately. MADE IN ITALY.

DIMENSIONS

COIFFEUSE WITH 8 DRAWERS
157x70x75h cm - Inch 61.8x27.5x29.5h

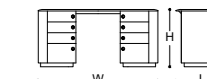

STOOL

Ø 45x50h cm - Inch Ø 17.7x19.6h

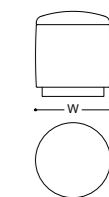
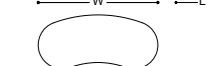

FINISHES

COIFFEUSE

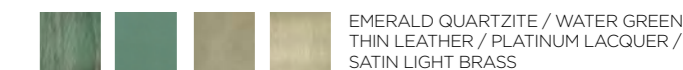

STOOL



CODE: 050351 CH038 C0086 (COIFFEUSE) / 050350 CT00C TX119 (STOOL), PORTOFINO FABRIC

NEMO

Towel rack in solid wood.
MADE IN ITALY

DIMENSIONS

SMALL:
82x31x80h cm - Inch 32.3x12.2x31.5h

LARGE:
122x36x120h cm - Inch 48x14.2x47.2h

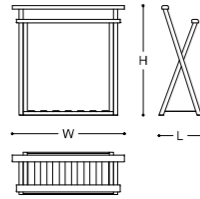

CODE: 045150 CA262 C0753 (LARGE)

FINISHES

BRUSHED BROWN OAK

NORBERT

Cloth stand in solid wood.
MADE IN ITALY.

DIMENSIONS

44x42x105h cm - Inch 17.3x16.5x41.3h

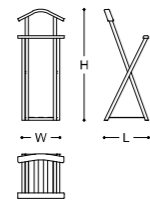

CODE: 045209 CA262 C0753

FINISHES

BRUSHED BROWN OAK

SEVEN

Magazine rack with a curved design, recalling the sinuous structure of the Morfeo, Onda and Sharon ranges.
MADE IN ITALY.

DIMENSIONS

32x53x45h cm - Inch 12.5x20.9x17.7h

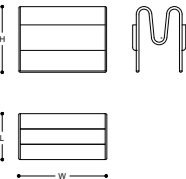

CODE: 050708 CH965 C0554

FINISHES

CANALETTO WALNUT / DOVE GREY LEATHER

TAO

Metal rack with or without central board. The base features a central pad covered with Parma fabric. MADE IN ITALY.

DIMENSIONS
104x36x166h cm - Inch 40.9x14.2x65.3h

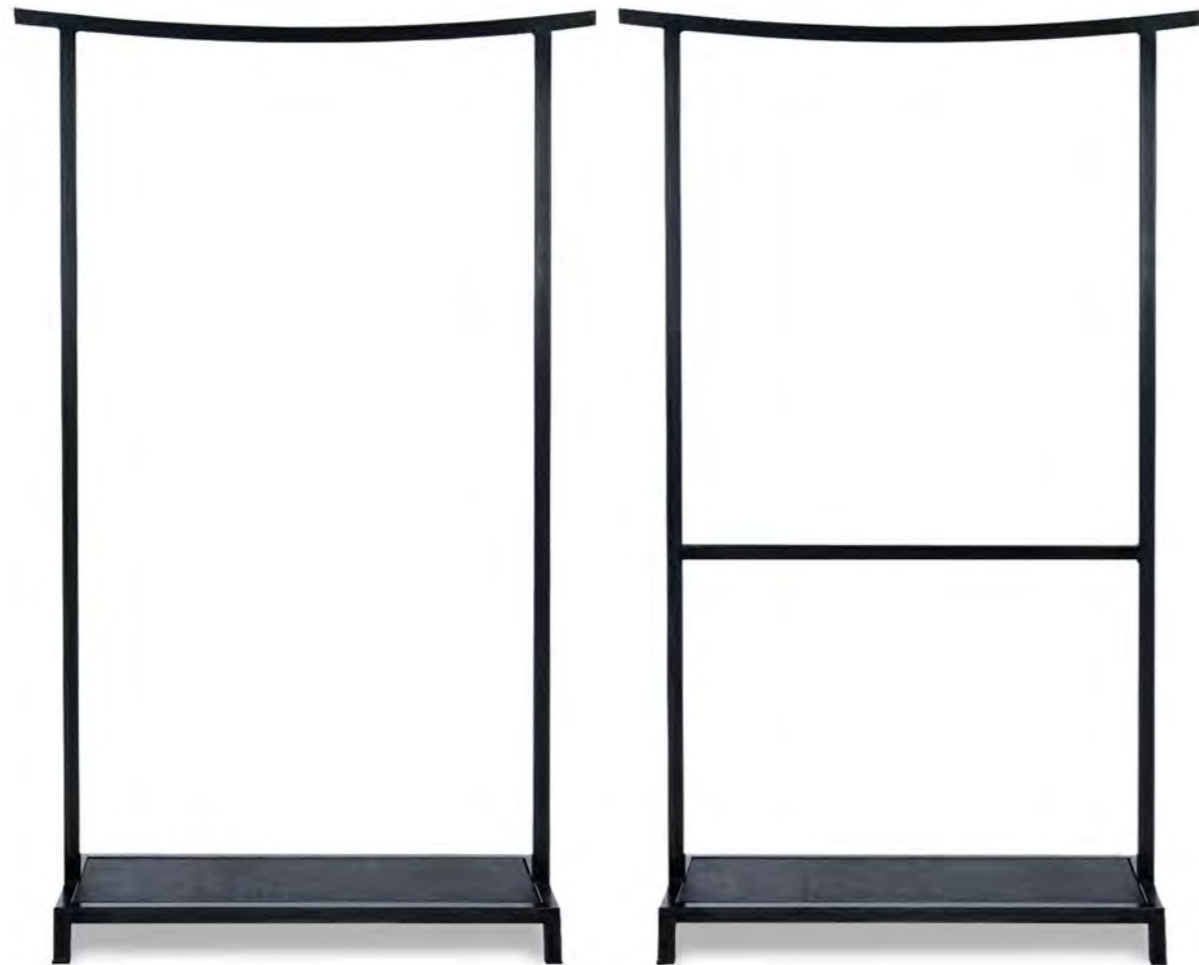
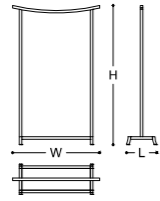

CODE: 044287 CA612 C0053

CODE: 044288 CA612 C0053

FINISHES

PAINTED STEEL /
PARMA FABRIC (TX157)

DIVA

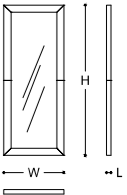

Floor standing mirror.
MADE IN ITALY.

DIMENSIONS
80x6x200h cm - Inch 31.5x2.4x78.7h



* CODE: 048386 CA881 C0041

FINISHES

-  BLACK MAPLE
-  BRUSHED BROWN OAK
-  TECHNICAL SHAGREEN FABRIC *

OMBRA

The Ombra screen features four panels. The lower part of each panel is empty, giving this decorative piece a lighter look. Ombra is available in two versions, the first with rotating panels showing fabric on one side and a mirror on the other, and the second with fixed fabric-covered panels. The options with mirrors presents a main structure in metal, conceived to counterbalance the weight of the glass and hence increasing the stability of the screen.
MADE IN ITALY.

DIMENSIONS
SINGLE PANEL:
55x4x180h cm - Inch 21.6x1.5x70.9h

OPEN AT 180°:
220x4x180h cm - Inch 86.6x1.5x70.9h

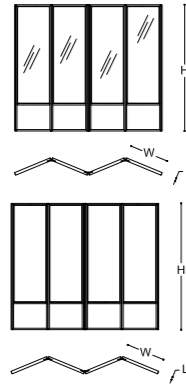

* CODE: 050113 TD081 TX073



** CODE: 050114 TD082 TX078

FINISHES

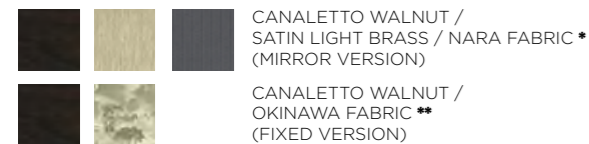

RONIN

Ronin is a tall decorative screen with three doors. The main feature of the screen is the integrated lighting system: each door is actually a LED panel with a color of 2700 kelvin to grant a warm atmosphere. Light sources run parallel to the vertical sides of the frame of each door, hence creating a gradient effect towards the center of the doors when lit. The screen is outlined by solid walnut and each door is marked by an intertwined metal grid inspired by the armor of Japanese samurai.
MADE IN ITALY.

DIMENSIONS
SINGLE PANEL:
60x5x180h cm - Inch 23.6x1.9x70.9h

OPEN AT 180°:
180x5x180h cm - Inch 70.9x1.9x70.9h

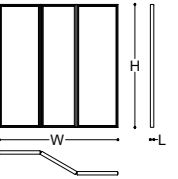

CODE: 050606 CH182 C4856

FINISHES



SESAMO

Sesamo is a two-door screen made of wide panels in solid wood. The surface is rich in the texture thanks to the use of Black-Ocre Carving, a finish marked by a beautiful three-dimensional appearance. The design is obtained by an irregular carving at multiple levels, in order to create different thicknesses of the wood. This effect is emphasized by the use of two contrasting tones: the whole black surface is carved and the resulting lines in relief are then lacquered in ocre.

MADE IN ITALY.

DIMENSIONS
110x5x140h cm - Inch 43.3x2x55.1h

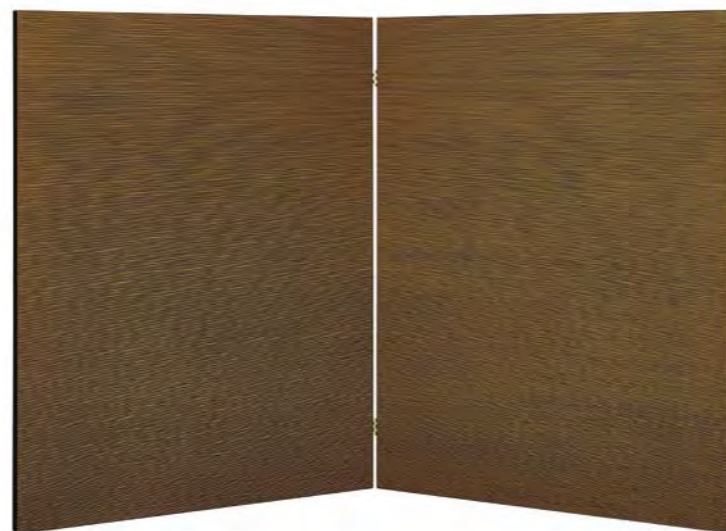
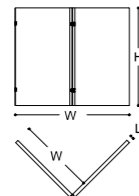

CODE: 050769 CH990 C0253

FINISHES

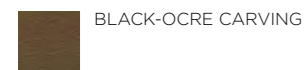

SIDE

Side is a decorative screen composed by three curved elements: by perfectly aligning them it is possible to create a thin sinuous shape, showing a continuous line. Side is characterized by the Carved Paulownia finish, whose natural warm color is emphasized by the three-dimensional surface recalling the iconic *canneté* texture typical of the Armani aesthetics.

DIMENSIONS
183x3 x175h cm - Inch 72x1l. x68.8h

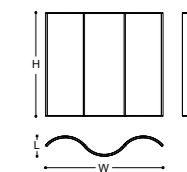

CODE: 050717 CH964 C0253

FINISHES

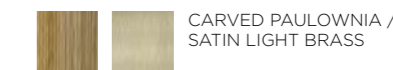

LIGHTING

- FLOOR LAMPS
- TABLE LAMPS
- LANTERNS
- WALL LIGHTS



NORIKO Table lamp/GALASSIA Small table



RONNIE Table lamp/RONDÒ Armchair/RONIN Screen



MIYA Floor lamp/CAMILLA Desk/CLASSIC Chair

ALADINO

Floor lamp with base and stem in Satin Black Nickel, grey or white pagoda fabric lampshade. A cylindrical lampshade, made with raffia and other special yarns, can be selected for this range; it is available in two colors, both with contrasting borders. MADE IN ITALY.

DIMENSIONS
81x48x190h cm - Inch 31.9x18.9x74.8h

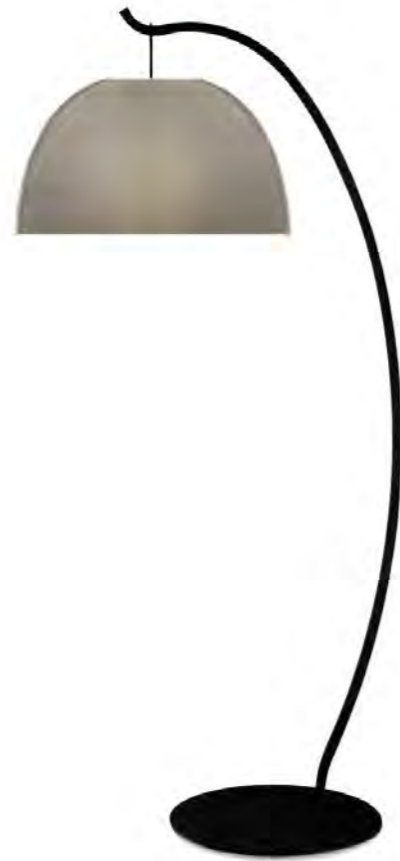
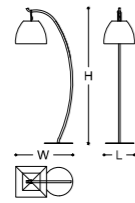

CODE: 049063 UP001 C0020 (BASE)
049064 CA236 C1040 (LAMP SHADE)

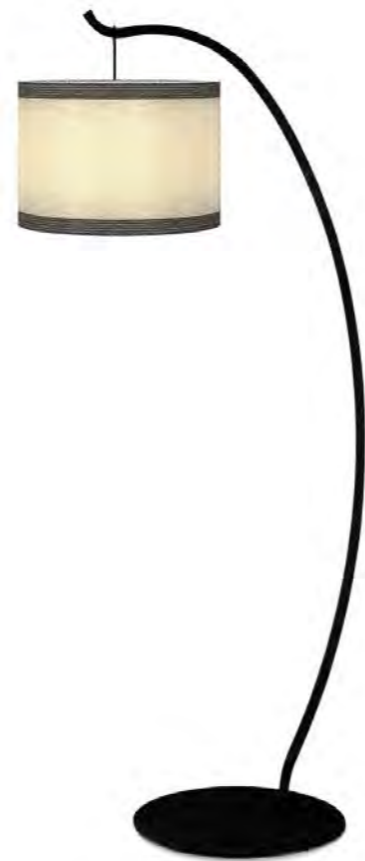

CODE: 049063 UP001 C0020 (BASE)
050652 CH206 C0720 (LAMP SHADE)

FINISHES



AURORA

Floor lamp with base and stem in Satin Black Nickel, beige fabric lampshade surrounded by a metal grid.
MADE IN ITALY.

DIMENSIONS
29x29x150h cm - Inch 11.4x11.4x59h

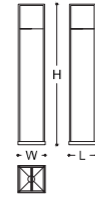

FINISHES

 SATIN BLACK NICKEL

CODE: 045617 UP001 C0020

CELEBRITY

Floor lamp with variable height, adjustable through a telescopic system with a blocking ring. Wooden structure, with upper stem and details in metal. Truncated pyramid lampshade in white, grey or ecru fabric.
MADE IN ITALY.

DIMENSIONS
45x45x142,5/189,5h cm - Inch 17.7x17.7x56.1/74.6h

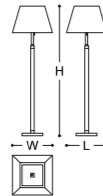

CODE: 049075 UP003 C1253 (BASE)
049077 CA236 C0015 (LAMP SHADE)

FINISHES

 SHINY SANTOS ROSEWOOD / BRONZED BRASS

EMME



Floor lamp with a wooden base. The particular manufacturing of the three legs reinterprets the classic tripod stand lamp in a modern style marked by a high level of craftsmanship: starting from a squared section at the bottom, the legs intersect at the top creating a triangular shape. Truncated cone lampshade in white fabric, with diffuser disc in the lower part.
MADE IN ITALY.

DIMENSIONS
Ø 53x191h cm - Inch Ø 20.9x75.2h



* CODE: 049091 UP007 C9453 (BASE)
049092 CA236 C0010 (LAMP SHADE)

FINISHES

 BLACK MAPLE / GLOSSY NATURAL BRASS
 VINTAGE BROWN OAK / GLOSSY NATURAL BRASS *

JOLANDA

Jolanda is a Murano lamp available both in the floor and table version, inspired by the shape of the traditional lanterns from the far east. The shade is completely hand made, following the ancient techniques of Murano glassmaking: a series of coloured matt glass rods are fused on a mass of white opal glass, in order to create streaks similar to those of a rock. After the process of tempering, the glass is worked by hand to get a matt finish. The lamp is illuminated by a led of 3000k to obtain a warm tone. The light is dimmable.
MADE IN ITALY.

DIMENSIONS
42x78x186,5h cm - Inch 16.5x30.7x73.4h

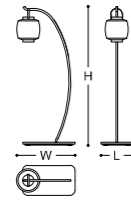

FINISHES

BRONZED BRASS /
DOVE GREY MURANO GLASS



CODE: 050027 UP008 C0454

MIYA

Lamps inspired to the soft atmospheres of the Armani Privé club in Milan. All versions feature an iconic lamellar cube that filters light in a very cozy and luxurious way. The floor version is dimmable and made in wood for what concerns the base and the lamellar structure, while vertical bars and other details are in metal. All wooden layers are painted in gold on the bottom, to increase the warm tone of the light.
MADE IN ITALY.

DIMENSIONS
24x24x115h cm - Inch 9.45x9.45x45.3h
28x28x145h cm - Inch 11x11x57h

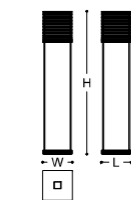

FINISHES

CANALETTO WALNUT /
SATIN LIGHT BRASS *

GREIGE PAINTED WOOD /
SATIN LIGHT BRASS



* CODE: 049347 UP005 C9553

NEMA

The Nema floor lamp features a distinctive design, whose geometric lines take inspiration from the idea of two folded paper sheets. The inner sides of the structure are available in a beautiful Shell Mosaic featuring mother of-pearl tiles, or printed with an onyx-inspired design. Nema is bifacial, since it is finished in the same way on both sides, and it can be easily become the focal point of a room thanks to its sculptural silhouette.
MADE IN ITALY.

DIMENSIONS
30x30x165h cm - Inch 11.8x11.8x64.9h

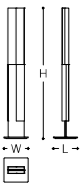

* CODE: 045935 UP045 C2710



** CODE: 045935 UP056 C0251

FINISHES

ONYX-TEXTURED METAL /
SATIN LIGHT BRASS *

SHELL MOSAIC /
SATIN LIGHT BRASS **

NEXT

Reading floor lamp with brass structure and black painted base in steel. The stem is divided in two segments that, together with the upper part, grant the best possible orientation of the lamp. A decorative - and removable - truncated cone shade in colored fabric (green, red or gold) envelops the light source. Large metal GA logo on the base.
MADE IN ITALY.

DIMENSIONS
10x65x150h cm - Inch 3.9x25.5x59h

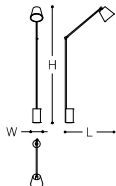

CODE: 045651 UP035 C0086

FINISHES

SATIN LIGHT BRASS



NIGHT

Reading floor lamp with V-shaped shade. The whole structure is in brass with the shade and the stem covered with leather. The shade can be oriented and features an on/off switch integrated on the back. The intensity of the light can be adjusted. MADE IN ITALY.

DIMENSIONS
36x16x145h cm - Inch 14.1x6.2x57h

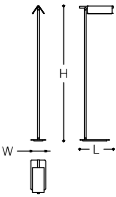

*CODE: 045616 UP028 C0086

FINISHES

-   DARK GREEN THIN LEATHER / SATIN LIGHT BRASS *
-   DOVE GREY THIN LEATHER / SATIN LIGHT BRASS

PAMELA

Pamela is a lamp available both in table and floor version. The distinctive feature of this lamp is the thin metal stem, sculpted to resemble a bamboo cane and connected to a circular base developed on more levels. On the table version, the switch/dimmer - featuring the GA logo and a touch technology - is located on the base; on the floor version, it can be found on the stem. Available with truncated cone shade in fabric (white, red or forest green) or in a special micro-perforated elm wood. The intricate design of the latter is inspired by wicker patterns, and creates a special see-through effect with geometrical reflections of the light. The wood of this shade is coupled with a inner layer of PVC and features decorative metal rings on the borders, as well as two diffuser discs (above and below the light source); the fabric shade, instead, features a upper disc only. A cylindrical lampshade, made with raffia and other special yarns, can be selected for this range; it is available in two colors, both with contrasting borders. MADE IN ITALY.

DIMENSIONS
Ø 50x182h cm - Inch Ø 19.7x71.6h



FINISHES

-  SATIN LIGHT BRASS



CODE: 050395 UP037 C0052 (BASE)
050396 CA236 C0010 (LAMP SHADE)



CODE: 050395 UP037 C0052 (BASE)
050653 CH207 C1511 (LAMP SHADE)

RAMAGE

Floor lamp with tripod structure. The legs are conceived to reproduce three bamboo canes in metal, hence making this lamp matchable with the Pamela range. Shade with truncated cone shape, in fabric or in a special micro-perforated elm wood. The intricate design of the latter is inspired by wicker patterns, and creates a special seethrough effect with geometrical reflections of the light. The wood of this shade is coupled with a inner layer of PVC and features decorative metal rings on the borders, as well as two diffuser discs (above and below the light source); the fabric shade, instead, features a upper diffuser disc only. MADE IN ITALY.

DIMENSIONS

Ø 50x175h cm - Inch Ø 19.6x68.8h



CODE: 050611 UP037 C0052 (BASE)
050396 CA236 C0010 (LAMP SHADE)

FINISHES



SATIN LIGHT BRASS



REA

Floor lamp inspired by the ones furnishing the halls and staircases of Palazzo Orsini in Milan, the historical palace hosting the headquarter of the Giorgio Armani company. Conceived as a metal ribbon, Rea presents thin inserts in wood on the sides. The main lighting source is located on the top part, but a second one runs on the back of the stem of the lamp: the two sources can be switched on/off and dimmed independently. Thanks to those features, the lamp irradiates a smooth cozy light. The range also includes a wall light option suitable for domotics. MADE IN ITALY.

DIMENSIONS
20x25x200h cm - Inch 7.9x9.8x78.7h

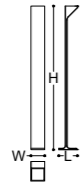

CODE: 050612 UP053 C0052

FINISHES



RETTA

Floor lamp inspired the shape of two bamboo canes, made in metal. The light sources are two: one is located on the top of the vertical cane, while another is on the end of the shorter cane. The shorter cane can rotate around its horizontal axis in order to be used as a spot light for reading. MADE IN ITALY.

DIMENSIONS
105x20x170h cm - Inch 41.3x7.8x66.9h

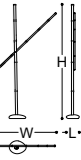

CODE: 050614 UP037 C0052

FINISHES

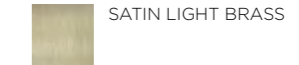

TERSILLA

Arched floor lamp with metal base and stem. Available with white or grey pagoda lampshade in fabric. A cylindrical lampshade, made with raffia and other special yarns, can be selected for this range; it is available in two colors, both with contrasting borders. MADE IN ITALY.



CODE: 049105 UP001 C0020 (BASE)
049106 CA236 C0010 (LAMP SHADE)

DIMENSIONS
189x40x209h cm - Inch 74.4x15.7x82.3h

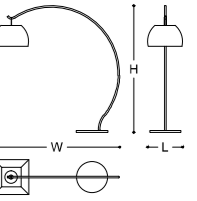

CODE: 049105 UP001 C0020 (BASE)
050653 CH207 C1511 (LAMP SHADE)

FINISHES

 SATIN BLACK NICKEL

ALABASTER

Cubic table lamp with wooden base and streaked alabaster lampshade.
MADE IN ITALY.

DIMENSIONS
26x26x26h cm - Inch 10.2x10.2x10.2h

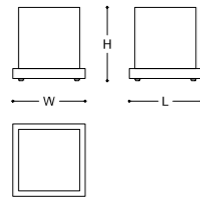

FINISHES



ALABASTER /
BRUSHED BROWN OAK



CODE: 048205 UP009 C2553

BLOOM

Table lamp with base in polished alabaster with metal details. The base is lit internally thanks to a led system that can be switched on/off independently from the lampshade. The pagoda-shaped lampshade is available in cream colour only.
MADE IN ITALY.

DIMENSIONS
48x48x75h cm - Inch 18.9x18.9x29.5h

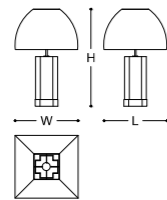

FINISHES



ALABASTER /
SATIN BLACK NICKEL



CODE: 049108 UP026 C0012 (BASE)
049109 CA236 C0012 (LAMP SHADE)

CELEBRITY

Table lamp with variable height, adjustable through a telescopic system with a blocking ring. Wooden structure, with upper stem and details in metal. Pagoda lampshade in white, grey or ecru fabric.
MADE IN ITALY.

DIMENSIONS
40x40x67/90h cm - Inch 15.8x15.8x26.4/35.4h

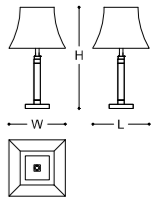

FINISHES

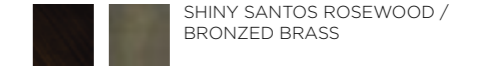

SHINY SANTOS ROSEWOOD /
BRONZED BRASS



CODE: 049070 UP003 C1253 (BASE)
049071 CA236 C0015 (LAMP SHADE)

CHERIE

Table lamp with rectangular base in metal and GA logo-shaped stem. The laser carved letters in metal surround an element covered in dark brown leather with lizard print. Truncated pyramid shade in grey or bronze fabric.
MADE IN ITALY.

DIMENSIONS
Ø 48x69h cm - Inch Ø 18.9x27.2h

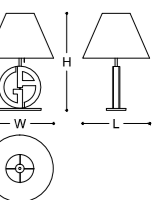

FINISHES



SATIN BLACK NICKEL



CODE: 049078 UP011 C0020 (BASE)
049072 CA236 C1844 (LAMP SHADE)

DIOGENE

Table lamp inspired to Eastern lanterns with structure in wood and metal. Available with the shade in black grid fabric.
MADE IN ITALY.

DIMENSIONS
24,5x24,5x48,5h cm - Inch 9.7x9.7x19.1h

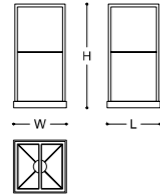

FINISHES



CODE: 045530 UP012 C0020

DONNA

Table lamp. The shape of the base is the same used on the Hope wall light. Available with gold fabric pagoda-shaped shade or white fabric truncated pyramid-shaped shade. Top diffuser disc.
MADE IN ITALY.

DIMENSIONS
VERSION WITH TRUNCATED PYRAMIDAL SHADE:
40x40x59,5h cm - Inch 15.8x15.8x23.4h

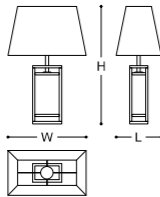

VERSION WITH PAGODA SHADE:
40x23x59,5h cm - Inch 15.8x9x23.4h

FINISHES



CODE: 049080 UP013 C0461 (BASE)
049081 CA236 C0161 (LAMP SHADE)



CODE: 049080 UP013 C0461 (BASE)
049082 CA236 C0010 (LAMP SHADE)

DORY

Table lamp with rectangular base. The two large faces with vertical orientation are clad with reptile-printed leather in cream color, while the sides are refined by large borders in golden metal. Truncated cone shade in white fabric. Top diffuser disc.
MADE IN ITALY.

DIMENSIONS
Ø 42x60h cm - Inch Ø 16.5x23.6h

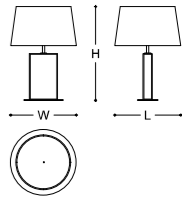

CODE: 049087 UP016 C0051 (BASE)
049084 CA236 C0010 (LAMP SHADE)

FINISHES



GILDA

Gilda is a table lamp with a Murano glass base. The base is produced by a traditional process in the furnace, in which several layers of coloured glass are superimposed to create this effect that will be different in every piece. Then it is blown individually in a mold determining the shape. After the tempering process the glass it is passed by a band to obtain the matt finish. The shade is a truncated cone with top diffuser disc, available in white fabric only. The base is lit internally thanks to a LED system that can be switched on/off independently from the lampshade.
MADE IN ITALY.

DIMENSIONS
Ø 39x57,5h cm - Inch Ø 15.4x22.6h

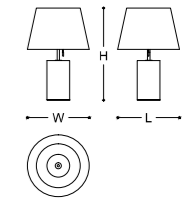

CODE: 049110 UP027 C0099 (BASE)
049111 CA236 C0010 (LAMP SHADE)

FINISHES

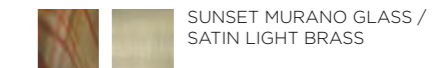

GLOW

Glow is a table lamp with a sculptural base and metal details. It is available with a particular white fabric lampshade which has an irregular shape that follows the design of the base. Top diffuser plate.
MADE IN ITALY.

DIMENSIONS
38x24x57,5h cm - Inch 15x9.4x22.6h

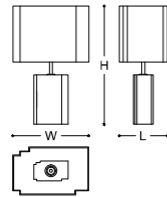

FINISHES

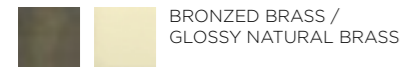

CODE: 049101 UP021 C0056 (BASE)
049102 CA236 C0010 (LAMP SHADE)

HACK

Hack is inspired by the shape of the classical lanterns from the Far East and it is completely hand made following the ancient techniques of Murano glassmaking. The glass shade is produced by a traditional process in the furnace, where a series of coloured glass rods are fused on a mass that is superimposed on an internal layer of white opal glass in order to create a series of veins similar to those of marble.
MADE IN ITALY.

DIMENSIONS
Ø 19x33,5h cm - Inch Ø 7.5x13.2h

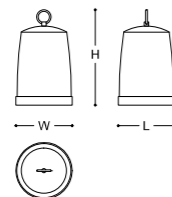

FINISHES



* CODE: 048916 UP023 C0454

HYADES

Hyades is inspired by the shape of the classical lanterns from the Far East and it is completely hand made following the ancient techniques of Murano glassmaking. The glass shade is produced by a traditional process in the furnace, where a series of coloured glass rods are fused on a mass that is superimposed on an internal layer of white opal glass in order to create a series of veins similar to those of marble. After the tempering process the glass it is passed by a band to obtain the matt finish.
MADE IN ITALY.

DIMENSIONS
Ø 36x49h cm - Inch Ø 14.2x19.3h

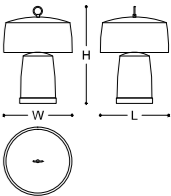

FINISHES

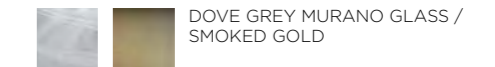

CODE: 048917 UP023 C0454

JOLANDA

The shade of Jolanda is made completely by hand, following the ancient techniques of Murano glassmaking. The glass shade is produced by a traditional process in the furnace, where a series of coloured glass rods are fused on a mass that is superimposed on an internal layer of white opal glass in order to create a series of veins similar to those of marble. The lamp is illuminated by LED of 3000° k.
MADE IN ITALY.

DIMENSIONS
Ø 31x45h cm - Inch Ø 12.2x17.7h

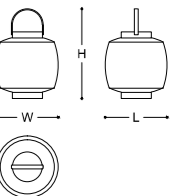

FINISHES

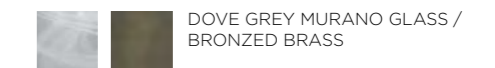

CODE: 050026 UP008 C0454

LOGO

This table lamp was the very first product ever designed for Armani/Casa, back in 1982, by Giorgio Armani himself: for this reason, it became the logo of the brand. The satinated black metal structure features a double lampshade in the shape of a truncated pyramid, made in ivory metachrylate.
MADE IN ITALY.

DIMENSIONS
48x48x82,3h cm - Inch 18.9x18.9x32.4h

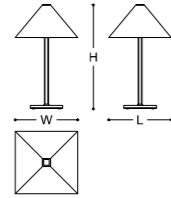

CODE: 045532 UP001 C2020

FINISHES



NEXT

Reading table lamp with brass structure and rectangular flat base in steel. The stem is divided in two leather-covered segments that, together with the upper part, grant the best possible orientation of the lamp. A decorative truncated cone shade in colored fabric, matching the leather, envelops the light source. Switch/dimmer in the shape of GA logo on the base.
MADE IN ITALY.

DIMENSIONS
20x57x58h cm - Inch 7.8x22.4x22.8h

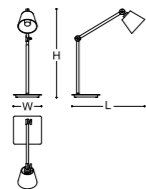

* CODE: 050134 UP028 C0086



** CODE: 050134 UP028 C0010

FINISHES



MIYA

Lamps inspired by the soft atmospheres of the *Armani Privé* club in Milan. All versions feature an iconic lamellar cube that filters light in a very cozy and luxurious way. The table version is dimmable and made in wood for what concerns the base and the lamellar structure, while vertical bars and other details are in metal; it is available in two color options. All wooden layers are painted in gold on the bottom, to increase the warm tone of the light. The lantern version (large and small), instead, is in greige painted wood and has a LED working with a battery device.
MADE IN ITALY.

DIMENSIONS
TABLE LAMP:
20x20x46h cm - Inch 7.9x7.9x18.1h

LARGE LANTERN:
20x20x26h cm - Inch 7.9x7.9x10.2h

SMALL LANTERN:
12x12x17h cm - Inch 4.7x4.7x6.7h

BATTERY DEVICE (lanterns only)
Recharge time: 3 hours
Autonomy at maximum light: 8 hours

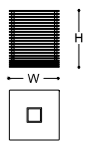
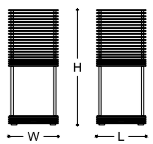

* CODE: 049346 UP015 C0356 (TABLE LAMP)



** CODE: 050392 UP015 C0356 (LARGE LANTERN)



** CODE: 049345 UP015 C0356 (SMALL LANTERN)

FINISHES

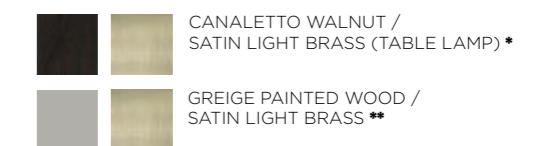

NIGHT

Reading table lamp with V-shaped shade. The whole structure is in brass with the shade and the stem covered with leather. The shade can be oriented and features an on/off switch integrated on the back. The intensity of the light can be adjusted. MADE IN ITALY.

DIMENSIONS
13x34x35h cm - Inch 5.1x13.3x13.7h

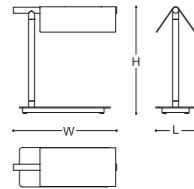

FINISHES



*CODE: 045616 UP028 C0554

NORIKO

Table lamp with base and shade in leather and details in brass. The cylindrical base contains the LED system, which is totally invisible from the side view. The shade can be oriented on the horizontal axis. Touch switch in the shape of a small GA logo in metal, located in the lower part of the base. MADE IN ITALY.

DIMENSIONS
15x43x40h cm - Inch 5.9x16.9x15.7h

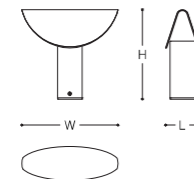

FINISHES



* CODE: 049057 UP028 C0086



** CODE: 049057 UP055 C0074

OREGON

Oregon is a large lamp with monolithic base. The pagoda shade is in champagne or grey fabric. MADE IN ITALY.

DIMENSIONS
55x55x74,5h cm - Inch 21.7x21.7x29.3h

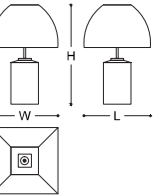

CODE: 044525 UP001 C0251 (BASE)
044526 CA655 C0056 (LAMP SHADE)

FINISHES

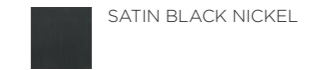

ORNELLA

Ornella is a table lamp with a lacquered base, available in three different versions. The particular feature of the lamp is in the base, where the hexagonal top and bottom sides are linked by diagonal facets: the final effect is a twisted look, which gives a sense of movement to the whole piece. Shade in fabric, truncated cone shape, available in white or beige. MADE IN ITALY.

DIMENSIONS
Ø 38x57h cm - Inch Ø 15x22.4h

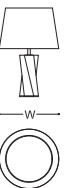

* CODE: 050124 UP039 C1084 (BASE)
050125 CA236 C0010 (LAMP SHADE)



** CODE: 050124 UP041 C2110 (BASE)
050125 CA236 C0010 (LAMP SHADE)

FINISHES



PALADINO

Paladino is a table lamp born from the idea of a three-dimensional *canneté* developed vertically: for this reason, the finish selected for this product is Brass Carved Liquid Metal, already an Armani/Casa icon. Liquid metal is a special lacquer made with real metal pigments, which give the finish the typical reflectance of real metal and its cold touch. Depending on the support, it is possible to obtain different effects: the carved version featured here creates the illusion of vintage brass rods. Available with truncated cone shade in fabric (white, red or green) with upper diffuser disc. MADE IN ITALY.

DIMENSIONS
Ø 45x57h cm - Inch Ø 17.7x22.4h

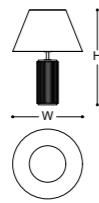

CODE: 050388 UP049 C2456 (BASE)
050394 CA236 C0086 (LAMP SHADE)



CODE: 050388 UP049 C2456 (BASE)
050394 CA236 C0074 (LAMP SHADE)

FINISHES



PAMELA

Pamela is a lamp available both in table and floor version. The distinctive feature of this lamp is the thin metal stem, sculpted to resemble a bamboo cane and connected to a circular base developed on more levels. On the table version, the switch/dimmer - featuring the GA logo and a touch technology - is located on the base; on the floor version, it can be found on the stem. Available with truncated cone shade in fabric (white, red or forest green) or in a special micro-perforated elm wood. The intricate design of the latter is inspired by wicker patterns, and creates a special see-through effect with geometrical reflections of the light. The wood of this shade is coupled with an inner layer of PVC and features decorative metal rings on the borders, as well as two diffuser discs (above and below the light source); the fabric shade, instead, features an upper disc only. A cylindrical lampshade, made with raffia and other special yarns, can be selected for this range; it is available in two colors, both with contrasting borders. MADE IN ITALY.

DIMENSIONS
Ø 42x67h cm - Inch Ø 16.5x26.4h

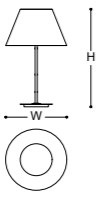

FINISHES



CODE: 050393 UP037 C0052 (BASE)
050394 CA236 C0086 (LAMP SHADE)



CODE: 050393 UP037 C0052 (BASE)
050394 CA236 C0074 (LAMP SHADE)

RONNIE

Table lamp with black lacquered aluminium structure and fabric shade. The use of aluminum makes this lamp less heavy and easier to move. The structure features the same detail marking the Play range of coffee/small tables, with joints on the edges becoming a distinctive decoration motif. Handle in brass, covered with thick leather (cuoio). MADE IN ITALY.

DIMENSIONS
26x20x65h cm - Inch 10.2x7.8x25.6h

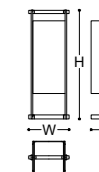

CODE: 050609 UP052 C4856

FINISHES



RUBIK

Cubic lantern with wooden structure and fabric shade, available in two different sizes. The structure features the same detail marking the Play range of coffee/small tables: the joints on the edges become a distinctive decorative motif, enriched by visible pivots in Satin Light Brass that match the metal feet of the lantern. MADE IN ITALY.

DIMENSIONS
SMALL VERSION:
26x24x29h cm - Inch 10.2x9.4x11.4h

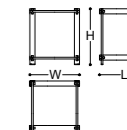

LARGE VERSION:
37x35x43h cm - Inch 14.5x13.8x17h



CODE: 050608 UP051 C4856
(LARGE LANTERN)



CODE: 050607 UP051 C4856
(SMALL LANTERN)

FINISHES



LOGO Mini

The very first home product designed by Giorgio Armani, the iconic Logo lamp, is presented in a "mini" version that can be used in different situations: as table lamp on bedside tables, for example, or to create a warm atmosphere while having dinner. Switch/dimmer on the metal base. Logo Mini is rechargeable and requires a power supply box (included) to work; this cable features a charger with USB.
MADE IN ITALY.

DIMENSIONS
15x15x24h cm - Inch 5.9x5.9x9.4h

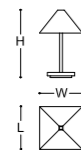

BATTERY DEVICE
Recharge time: 2 hours
Autonomy at maximum light: 7 hours

FINISHES



GOLDEN METHACRYLATE /
SATIN LIGHT BRASS



CODE: 050129 UP044 C0161

NELLY

Rechargeable wireless lantern. Nelly is lit through a LED light placed below the top part, completely invisible from the side view and powered by a battery system. Switch in brass placed on the top. The four sides are in Bronze Methacrylate. Moving this lamp is easy thanks to the large handle in metal: in this way, Nelly can be used also outdoor*.
MADE IN ITALY.

*Note: the lamp is not waterproof.

DIMENSIONS
15x15x42h cm - Inch 5.9x5.9x16.5h

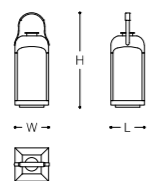

BATTERY DEVICE
Recharge time: 3 hours
Autonomy at maximum light: 8 hours

FINISHES



SATIN LIGHT BRASS /
BRONZE METHACRYLATE



CODE: 045313 UP028 C0086

PICNIC

Picnic features a bamboo-shaped handle (fixed) and a switch/dimmer located in the upper part. The sides are in transparent methacrylate and show a decoration with concentric rectangles, obtained thanks to a laser engraving in the methacrylate itself: in this way, the lantern creates a particular effect when lit. Available in two sizes, Picnic is presented in a special metal in champagne color developed for this range only. The inner cylinder - containing the LED lighting source - is in natural alabaster.
MADE IN ITALY.

DIMENSIONS
SMALL VERSION:
15x15x29h cm - Inch 5.9x5.9x11.4h

LARGE VERSION:
25x25x48h cm - Inch 9.8x9.8x18.9h

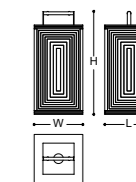

CODE: 050390 UP050 C1255
(LARGE LANTERN)

CODE: 050391 UP050 C1255
(SMALL LANTERN)

FINISHES

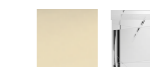

CHAMPAGNE METAL /
TRANSPARENT METHACRYLATE

OZ

Oz is a tiny cubic lamp conceived for the re-opening of the Emporio Armani Café in Milan. Light filters through a methacrylate shade with golden mesh, to create and diffuse a warm tone. Switch/dimmer on the metal base. Oz is rechargeable and requires a power supply box (included) to work; this cable features a charger with USB.
MADE IN ITALY.

DIMENSIONS
10x10x11h cm - Inch 3.9x3.9x4.3h

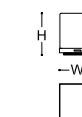

BATTERY DEVICE
Recharge time: 2 hours
Autonomy at maximum light: 7 hours

FINISHES



GOLDEN METHACRYLATE /
SATIN LIGHT BRASS



CODE: 050131 UP044 C0161

SIBILLA

Sibilla is a tiny cubic lamp mixing Giorgio Armani's favourite shape - the square - with the monogram featuring his initials. The GA logo is reproduced in series in order to build the entire shade of the lantern, lit by a cozy warm light and projecting the logo all around. Switch/dimmer on the metal base. Sibilla is rechargeable and has a LED working with a battery device.
MADE IN ITALY.

DIMENSIONS
20x20x25h cm - Inch 7.8x7.8x9.8h



BATTERY DEVICE
Recharge time: 3 hours
Autonomy at maximum light: 8 hours



CODE: 050716 UP015 C0056

HOPE

Hope was designed by Armani/Casa for the private residences of Giorgio Armani, the Armani Hotels and the projects of the Interior Design Service of Armani/Casa. The structure of this wall light is taken from the base of the Donna table lamp. The structure is in metal with the diffusor in white fabric. Hope features a hook on the back to fix it easily on the wall.
MADE IN ITALY.

DIMENSIONS
15x10,5x30h cm - Inch 5.9x4.1x11.8h

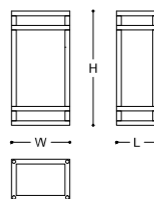

FINISHES
SMOKED GOLD



CODE: 048693 UP019 C0010

OPERA

Opera is an elegant wall light featuring a metal structure and a selenite mosaic: this stone, marked by its pearlescent white surface, is left unpolished to highlight its natural beauty and diffuse light in a very particular way.
MADE IN ITALY.

DIMENSIONS
33x9x33h cm - Inch 13x3.5x13h

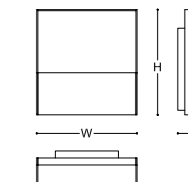

CODE: 050132 UP036 C6210

FINISHES
SELENITE /
SATIN LIGHT BRASS

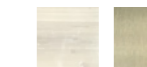

REA

Wall light inspired by the lamps furnishing the halls and staircases of Palazzo Orsini in Milan, the historical palace hosting the headquarter of the *Giorgio Armani* company. Rea presents thin inserts in wood on the sides. Rea is suitable for domotics.
MADE IN ITALY.

DIMENSIONS
20x14x14h cm - Inch 7.8x5.5x5.5h

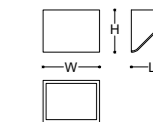

FINISHES
CANALETTO WALNUT /
SATIN LIGHT BRASS

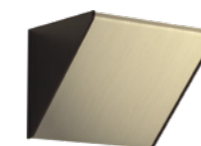
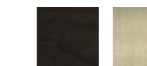

CODE: 050613 UP053 C0052

POWER SUPPLY BOXES

All Armani/Casa lamps work thanks to a LED system, which requires a specific power supply box. Depending on the lamp, different boxes can be available; each power supply box comes with three interchangeable plugs (CEE, UK, US). Please check the current Pricelist for further information.

030146 CA220 C0020 – Cable for table lamp with on/off switch, total length 1.8 mt
 030147 CA220 C0020 – Cable for floor lamp with on/off switch, total length 1.8 mt
 030148 CA220 C0020 – Cable without switch, total length 1.8 mt
 030149 CA220 C0020 – Cable for table lamp with dimmer, total length 1.8 mt
 030150 CA220 C0020 – Cable for floor lamp with dimmer, total length 1.8 mt

TECHNICAL DATA

LED lifespan: 50,000 hours.
 Input: 100-240V - 0.7A, 50-60Hz
 For indoor use only.

RANGE NAME	TYPE	MATCHING POWER SUPPLY BOX				
		030146	030147	030148	030149	030150
ALABASTER	Table	X			X	
ALADINO	Floor		X			X
AURORA	Floor		X			X
BLOOM	Table			X		
CELEBRITY	Floor		X			X
CELEBRITY	Table	X			X	
CHERIE	Table	X			X	
DIOGENE	Table	X			X	
DONNA	Table	X			X	
DORY	Table	X			X	
EMME	Floor		X			X
GILDA	Table			X		
GLOW	Table	X			X	
HACK	Table	X			X	
HOPE	Wall light			none		
HYADES	Table	X			X	
JOLANDA	Floor			X		
JOLANDA	Table			X		
LOGO	Table	X			X	
LOGO Limited Edition	Table			X		
LOGO MINI	Lantern			none		
MIYA	Floor			X		
MIYA	Lanterns			X		
MIYA	Table			X		
NELLY	Lantern			X		
NEMA	Floor			X		
NEXT	Floor		X			X
NEXT	Table			X		
NIGHT	Floor			X		
NIGHT	Table			X		
NORIKO	Table			X		
OPERA	Wall light			none		
OREGON	Table	X			X	
ORNELLA	Table	X			X	
OZ	Lantern			none		
PALADINO	Table	X			X	
PAMELA	Floor			X		
PAMELA	Table			X		
PICNIC	Table			X		
RAMAGE	Floor			X		
REA	Floor			X		
REA	Wall light			none		
RETTA	Floor			X		
RONNIE	Table	X			X	
RUBIK	Table	X			X	
SIBILLA	Lantern			X		
TERSILLA	Floor		X			X

RUGS & MATS



RUGS

All Armani/Casa rugs are entirely hand made by Nepalese artisans who master the traditional technique of hand-knotting. The high density - 100 knots per square inch - together with the use of many different yarns in terms of color and composition permits to obtain exceptional quality and aesthetics. To maintain those high standards, the production process is particularly complex and requires an average time of 21 weeks.

DYEING AND KNOTTING

The dyeing of the yarns is made by hand and with a constant comparison to master samples, in order to reduce the discrepancy that naturally occurs from lot to lot. Once all yarns are ready, artisans begin the knotting: only the most skillful artisans can work on Armani/Casa designs, since their incredibly rich scales of shaded colors need frequent changes of yarn that can be managed only by the best long-experienced knotters.

WASHING AND FINISHING

After the knotting, each rug is washed and dried to revive colors. The drying phase, in particular, is carried out in open-air environments to avoid aggressive treatments that could compromise the quality of the fibers. If the carpet features an accentuated three-dimensionality of the surface, a final scissor-cutting is performed by hand.

CORPORATE SOCIAL RESPONSIBILITY

As part of the Armani Group, Armani/Casa is particularly sensitive to social aspects. The brand totally fulfills the Nepalese laws which grant the respect of the rights of knotters in terms of working hours per day, Monday-to-Friday shifts, proper wages and age of the employees.

MATS

WEAVING

Mats are thin rugs made by using a pit loom. As the name suggests, this type of loom fits in a pit where artisans weave the rug through the aid of special pedals. In this technique, the mat is weaved parallel to the ground, which helps making those rugs less dense and stiff. While the warp is kept in tension thanks to two rows of pegs, the wefts are inserted by hand to create the design. A high level of craftsmanship is required to obtain those products, marked by the absence of pile and backing.

COLORS

The colors printed in this catalogue give only an idea of the actual hue of the final product. We suggest checking the updated samples available in all our stores. Always keep in mind that slight color variations may occur from dye lot to dye lot.

DESIGN

To determine the direction in which the design will be developed on rectangular carpets, please refer to the related technical sheets or pictures in this catalogue. When ordering a rug, the first size communicated must correspond to the horizontal dimension (as photographed) of the carpet itself.

SIZES

Due to the handmade nature of our products, a size variation of up to 5% in relation to the ordered size may occur. Rugs exceeding a total of 27 square meters have dedicated prices that will be calculated upon request.

SUSTAINABILITY

Armani/Casa mats are made by using yarns colored through a 100% ecological dyeing process with azo-free hues. They do not contain any harmful substance for the environment, pets or human beings: our suppliers operate in compliance to REACH SHVC regulations.



ARMSTRONG

Striped rug reinterpreting the *canneté* motif typical of the Armani style, available in custom size. Density: 100 knots/squared inch. The carpet is hand knotted without any child labour. MADE IN NEPAL.

MATERIALS
50% SILK / 50% WOOL

OTHER COLORS

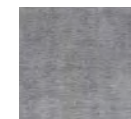

STEEL BLUE



PEARL

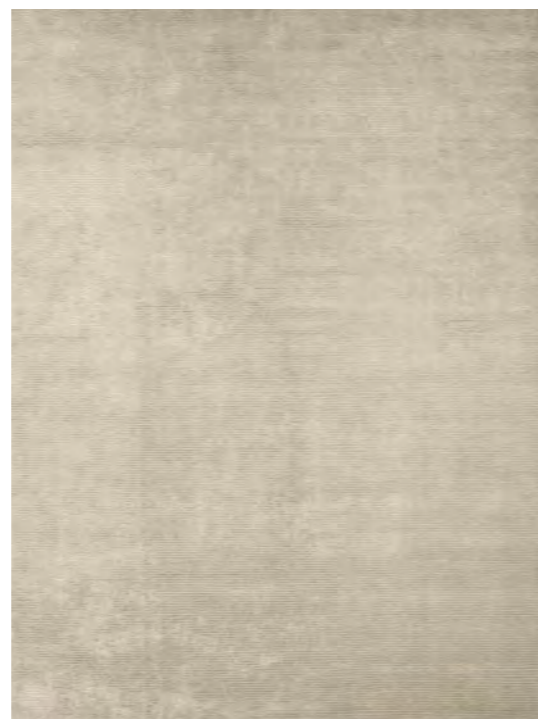

SAND

BAX

Rug with geometric Art Déco motif, available in custom size. Density: 100 knots/squared inch. The carpet is hand knotted without any child labour. MADE IN NEPAL.

MATERIALS
50% WOOL / 30% MATKA SILK / 20% SILK

OTHER COLORS



PEARL

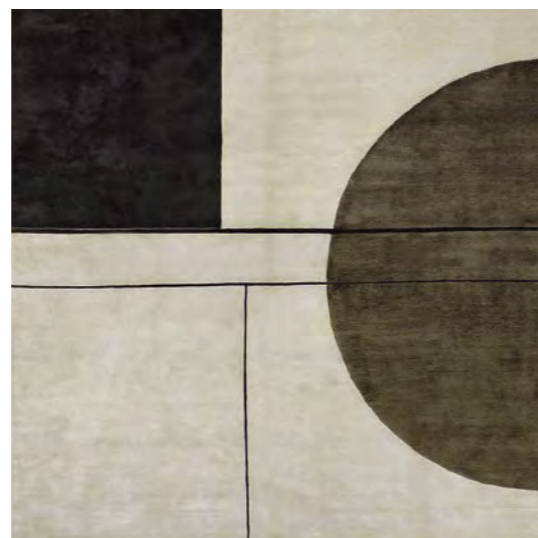

IVORY / DARK BROWN

BURT

Rug with discontinued multistriped motif, available in custom size. Density: 100 knots/squared inch. The carpet is hand knotted without any child labour. MADE IN NEPAL.

MATERIALS
100% SILK



IVORY / BLACK

CADRE

Rug with striped effect and contrasting frame, available in custom size. The delicate tone-on-tone narrow-stripe effect is obtained thanks to the use of two different techniques: bouclé wool and cut-pile viscose. The contrast between the alternating glossy and matt yarns adds a sophisticated touch to the contemporary decoration. Density: 100 knots/squared inch. The carpet is hand knotted without any child labour. MADE IN NEPAL.

MATERIALS
62% VISCOSE / 38% WOOL



GREY / BEIGE

CHAPLIN

Carpet with mélange effect, available in custom size. The sober look is given by the richness obtained through the matching of two different yarn colours. Density: 100 knots/squared inch. The carpet is hand knotted without any child labour.
MADE IN NEPAL.

MATERIALS
100% VISCOSE



GREY / ANTHRACITE

CRONOS

Rug with tone-on-tone moiré effect, available in custom size. Cronos emphasizes the subtle link to the world of fabrics and hints at the precious materials marking Armani/Casa furniture through the imitation of wood grain patterns. Density: 100 knots/squared inch. The carpet is hand knotted without any child labour.
MADE IN NEPAL.

MATERIALS
50% SILK / 50% WOOL

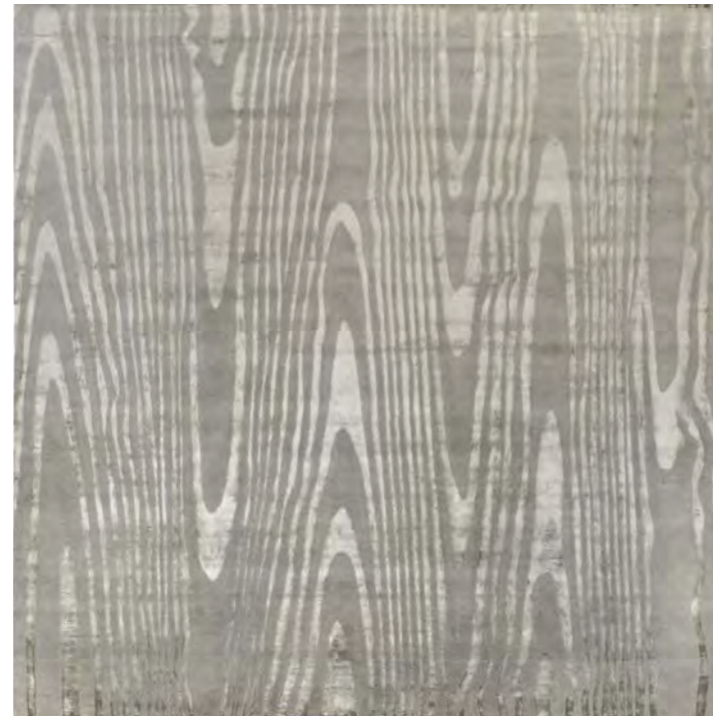

OLIVE GREY

CROQUIS

Rug with an Art Déco floral motif, available in custom size. The design is determined by the different trimming heights of the silk, which create an elegant three-dimensional effect. This elaborate processing is emphasized by the lustre of the silk that makes this carpet particularly precious. Density: 100 knots/squared inch. The carpet is hand knotted without any child labour.
MADE IN NEPAL.

DIMENSIONS
Due to the pattern of the carpet, for the rectangular shape we suggest a size of 290x390 cm. Other sizes can be ordered only after the approval of the design.

MATERIALS
100% SILK



BEIGE

OTHER COLORS



OFF WHITE

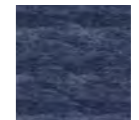

POWDER BLUE

ECCELISO

Rug with irregular *canneté* effect, available in custom size. The pattern is obtained by using two different techniques, loop pile and cut-pile, with different height. The alternance of glossy silk and matt wool emphasizes this effect. The carpet is hand knotted without any child labour.
MADE IN NEPAL.

MATERIALS
50% SILK / 50% WOOL



BEIGE / GREY

GEM

Rug with loops pile border, available in custom size. The loops pile technique is developed with different heights on the vertical borders only, creating a particular dégradé motif. Density: 100 knots/squared inch. The carpet is hand knotted without any child labour.
MADE IN NEPAL.

MATERIALS
100% SILK



MILITARY

OTHER COLORS



BLUE SHADOW

GINNY

Rug with interrupted stripes design, available in custom size. This carpet presents the same design of the Rebel rug, but with an interrupted pattern. The interruption of the stripe is created by the loop pile effect in a lower pile height. Density: 100 knots/squared inch. The carpet is hand knotted without any child labour.
MADE IN NEPAL.

MATERIALS
100% SILK



BEIGE / WATER GREEN

OTHER COLORS



GREY

JAEN

Rug with shaded stone texture, available in custom size. The impressive design evokes a marble slab and recalls the Nabucco wallpaper pattern. The fine shading effect of the different yarns ensures a very detailed pattern. Density: 100 knots/squared inch. The carpet is hand knotted without any child labour.
MADE IN NEPAL.

MATERIALS
100% SILK



SAND

OTHER COLORS

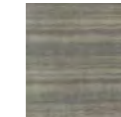

CREAM

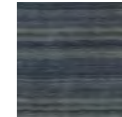

JADE

MASON

Rug with Art Déco inspired labyrinth design, available in custom size. The décor is created with relief and carving techniques, as well as with different quality yarns. The wool yarns create the ground where the silk yarns arise at times over the surface, to highlight the design. Density: 100 knots/squared inch. The carpet is hand knotted without any child labour.
MADE IN NEPAL.

MATERIALS
65% SILK / 35% WOOL



CHAMPAGNE

OTHER COLORS



OFF WHITE



PEARL

MAX

Rug with large shaded stripes, available in custom size. The fading stripes are created thanks to the different colour tones and with shiny and matt effect of the wool and silk yarns. Density: 100 knots/squared inch. The carpet is hand knotted without any child labour. MADE IN NEPAL.

MATERIALS
50% SILK / 50% WOOL



SAND

OTHER COLORS



PEARL

MILES

Rug with wavy design, available in custom size. The three-dimensional effect to the full width design comes from the relief technique and from the shading of the stripe lines. Density: 100 knots/squared inch. The carpet is hand knotted without any child labour. MADE IN NEPAL.

DIMENSIONS
Due to the pattern of the carpet, we suggest a size of 300x400 or 400x400 cm. Other sizes can be ordered after the approval of the design.

MATERIALS
100% SILK



TAUPE / CHAMPAGNE

MORGAN

Rug with striped chevron design, available in custom size. Wavy chevron stripes create an intertwined macro effect on this silk carpet. The design is created with carving techniques as well as with the tone-on-tone colouring. Due to the modularity of the design - based on a 150x150 cm square - the carpet is presented in special sizes (see below for details). Density: 100 knots/squared inch. The carpet is hand knotted without any child labour. MADE IN NEPAL.

DIMENSIONS
The Morgan range can be ordered as follows:
300x450 cm - Inch 118.1x177.2 (Only option available for showroom display)
450x450 cm - Inch 177.2x177.2
450x600 cm - Inch 177.2x 236.2

MATERIALS
100% SILK



PEARL / PLATINUM

NOIR

Gradient colored stripes fading from white to a pitch black background give a dramatic twist to this precious rug in silk. The silk enhances the graphic perspective design with strong color contrast, while the carving makes the precise lines to stand out. Available in custom size. Density: 100 knots/squared inch. The carpet is hand knotted without any child labour. MADE IN NEPAL.

DIMENSIONS
Due to the pattern of the carpet, we suggest a size of 300x400cm. In case of other sizes, the design will be scaled to match the dimensions requested.

MATERIALS
100% SILK



BLACK / WHITE

NOONA

The wool background highlights the horizontal silk stripes in relief. This classic Armani/Casa pattern, in refined hues, offers a sophisticated background for the interior décor. Available in custom size. Density: 100 knots/squared inch. The carpet is hand knotted without any child labour. MADE IN NEPAL.

MATERIALS
50% SILK / 50% WOOL

OTHER COLORS



POWDER BLUE / GREY

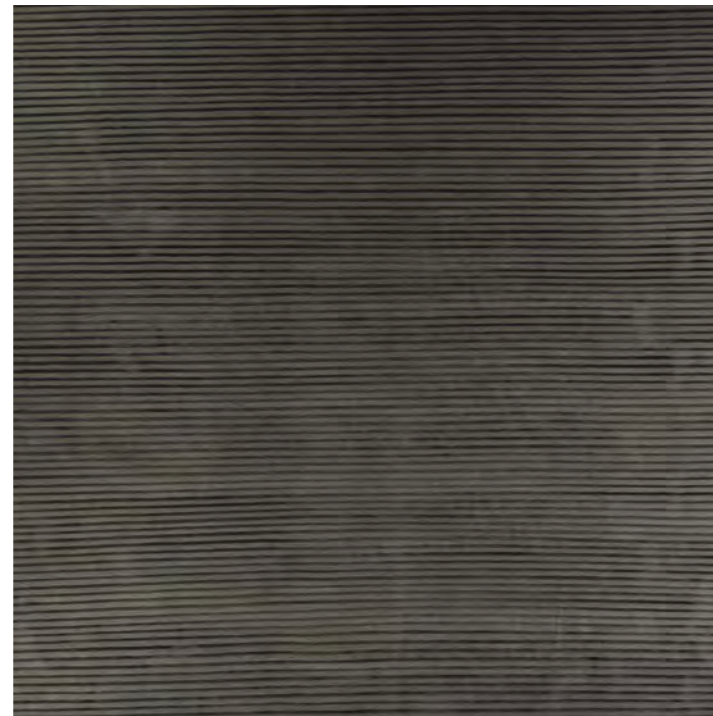

BLACK / ANTHRACITE

NOVA

Rug with an irregular grid design highlighted with relief. The background is created with the loop technique in wool, giving a lively texture and contrast to the design on the cut silk surface. Available in custom size. Density: 100 knots/squared inch. The carpet is hand knotted without any child labour. MADE IN NEPAL.

DIMENSIONS
Due to the pattern of the carpet, we suggest a size of 300x400cm or 400x400cm. In case of other sizes, the design will be scaled to match the dimensions requested.

MATERIALS
95% SILK / 5% WOOL

OTHER COLORS



MILITARY / BEIGE



SAND



ICE



NOVA Military / Beige

OBI

The design of this rug takes inspiration from the Asian culture, from ribbons and knots of the *obi*, the belts of Japanese kimonos. Those belts were traditionally made with pure silk, like the precious ground of the carpet crossed by wool lines. A frame running on the edge of the rug completes the three-dimensional grid. Available in custom size; on smaller rugs, the design will be resized to better fit the surface. Density: 100 knots/squared inch. The carpet is hand-knotted without any child labour. MADE IN NEPAL.

MATERIALS
50% SILK / 50% WOOL

OTHER COLORS

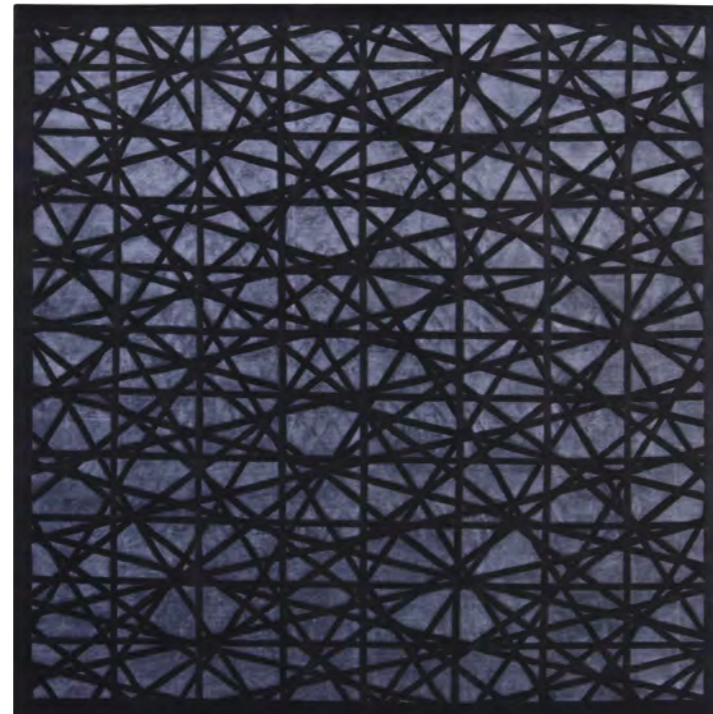

NIGHT BLUE

ORCHESTRA

This rug shows a vintage design, obtained with a production process which is particularly long and difficult. Density: 100 knots/squared inch. Available in custom size. The carpet is hand-knotted without any child labour. MADE IN NEPAL.

MATERIALS
100% VISCOSE

OTHER COLORS



PETROLEUM / ICE

ORIENTE

A design inspired by the Far East, featuring trees and hills shading into clouds to create an "infinite" perspective. The stunning level of detail is achieved by using a complex production process, which requires frequent changes of fibers in different colors while hand knotting; the result is a carpet showing thousands of shades and hues, recalling a sort of watercolor effect. Available in custom size. Density: 100 knots/squared inch. The carpet is hand-knotted without any child labour. MADE IN NEPAL.

MATERIALS
100% SILK

OTHER COLORS

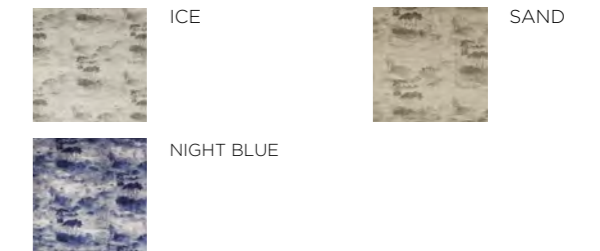

PETROLEUM

PABLO

Pablo shows a design featuring two frames running on all borders of the carpet. The outer one, like the central part, is made with cut pile technique on silk and features a watercolor effect to make this frame more vivid; the inner one is thin and is obtained through a loop technique on wool. The alternance of different three-dimensional effects and color shades increases the contrast between all parts. Density: 100 knots/squared inch. The carpet is hand-knotted without any child labour. MADE IN INDIA.

MATERIALS
80% SILK / 20% WOOL



GOLD / IVORY

PARADE

Parade is marked by plain horizontal lines. The wool background with silk lines in relief creates a three-dimensional *canneté*-inspired texture. The vertical lines cross the horizontal ones and create the illusions of irregular *canneté* tiles: the final design is a sort of irregular checkerboard, which echoes another iconic Armani motif. The entire rug is made with the cut technique; the three-dimensional effect is made more evident by the pile of the *canneté* lines, which is longer than the others. Density: 100 knots/squared inch. The carpet is hand-knotted without any child labour. MADE IN INDIA.

MATERIALS
60% SILK / 40% WOOL

OTHER COLORS

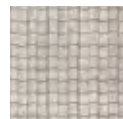

BLUE / LILAC / SAND

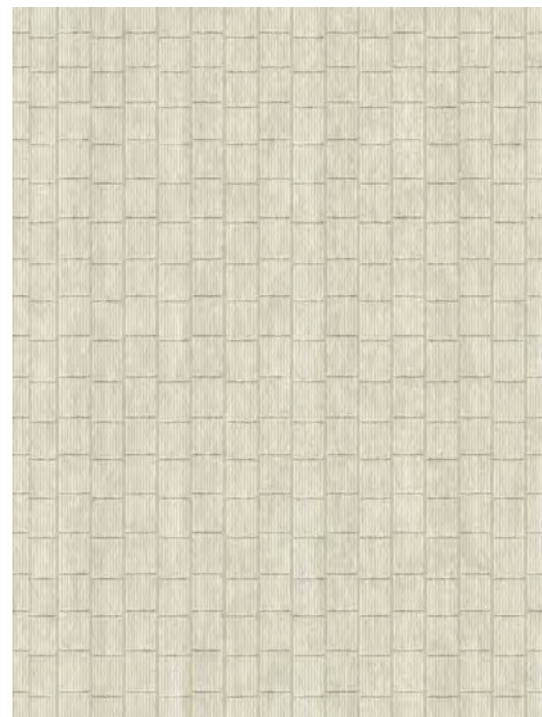

PEARL

PURFLE

The design of the Purfle rug is obtained by playing with the round GA logo, deconstructed in order to create a repeating geometric module. A thin frame runs on all borders of the carpet, made with loop technique as the background; the repeating design, instead, is made with the cut pile technique, so that it remains more shiny than the other parts and hence more visible even on a tone-on-tone color palette. Density: 100 knots/squared inch. The carpet is hand-knotted without any child labour. MADE IN NEPAL.

MATERIALS
100% SILK



ICE



PARADE Blue / Lilac / Sand



PHILOSOPHER Silver / Dove grey / Azure

PHILOSOPHER

The design of the Philosopher rug takes inspiration from the intertwined design of some fabrics within our collection. The background is in silver silk with both cut pile and loop technique; the texture in relief is given by horizontal lines in Dove Grey and vertical ones in Azure. The three-dimensional effect is particularly evident on this carpet. Density: 100 knots/squared inch. The carpet is hand-knotted without any child labour. MADE IN INDIA.

MATERIALS
100% SILK



SILVER / DOVE GREY / AZURE

REBEL

Rug with striped design, available in custom size. Density: 100 knots/squared inch. The carpet is hand knotted without any child labour. MADE IN NEPAL.

MATERIALS
50% SILK / 50% NETTLE (cream / beige option)
100% SILK (white / black option)

OTHER COLORS

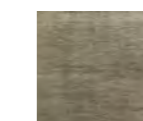

IVORY / BLACK



MILITARY

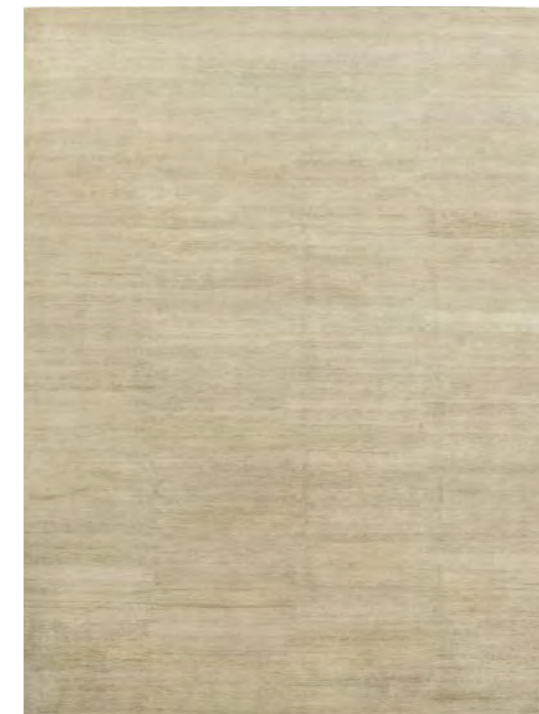

CREAM / BEIGE

REAME

Rug with palm leaf motif, available in custom size. Density: 100 knots/squared inch. The carpet is hand knotted without any child labour.
MADE IN NEPAL.

DIMENSIONS

Due to the pattern of the carpet, we suggest a size of 400x400 cm. Other sizes can be ordered after the approval of the design.

MATERIALS

50% SILK / 50% WOOL

OTHER COLORS



PEARL



PETROLEUM



TAUPE / BEIGE

TUTANKHAMON

Rug with alligator skin design, available in custom size. Density: 100 knots/squared inch. The carpet is hand knotted without any child labour.
MADE IN NEPAL.

MATERIALS

90% SILK / 10% WOOL

OTHER COLORS

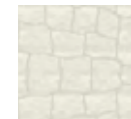

OFF WHITE



GREY



REAME Taupe / Beige

RASHOMON

Rashomon features two iconic elements of the Armani aesthetics: the checkerboard motif and *canneté*. The mat is made by alternating squared modules with a different orientation - vertical or horizontal - of three-dimensional lines, developed using contrasting colors. The result is a mat with a maxi-woven effect. Available in two colors. MADE IN INDIA.

DIMENSIONS
Custom size.

MATERIALS
80% WOOL FROM NEW ZEALAND / 20% COTTON

OTHER COLORS



NATURAL

RIDGE

Ridge is a mat characterized by vertical lines in relief, which create the illusion of a typical motif of the Armani style: *canneté*. The rows are interrupted by contrasting color blocks of different sizes. Ridge features a tone-on-tone border running on the upper and the lower side. Available in two colors. MADE IN INDIA.

DIMENSIONS
Custom size.

MATERIALS
85% WOOL FROM NEW ZEALAND / 15% COTTON.
BINDING: 100% LINEN

OTHER COLORS

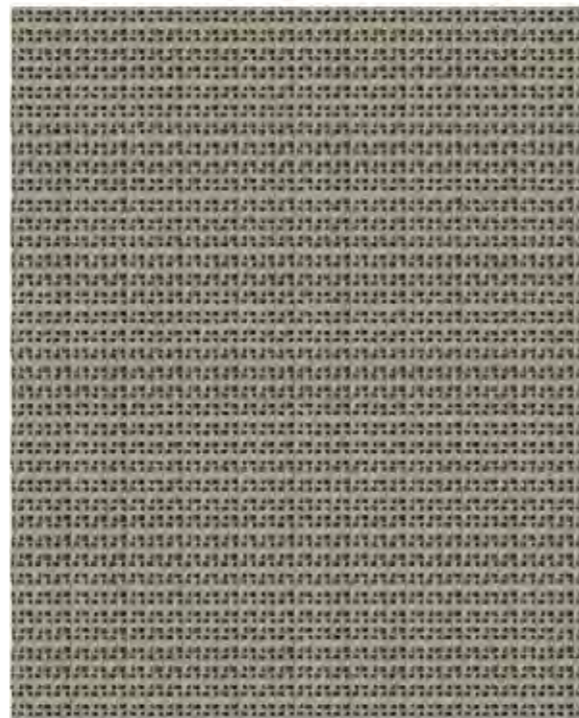
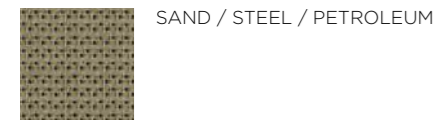

ICE / GREY

ROY

The three-dimensional texture made by thick lines of the mat creates the effect of a tatami, the typical Japanese carpet, depicted in macro scale. Roy has a tone-on-tone edge and is available in four different colors. MADE IN INDIA.

DIMENSIONS
Custom size.

MATERIALS
50% JUTE / 40% VISCOSE / 10% WOOL

OTHER COLORS

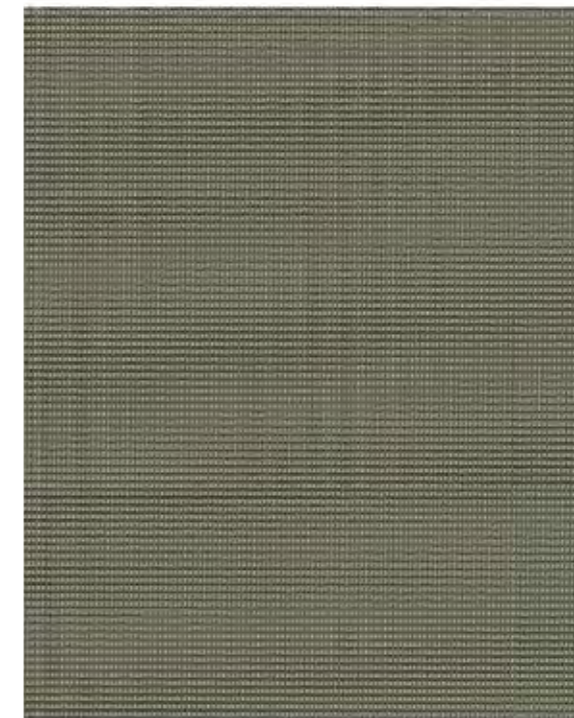
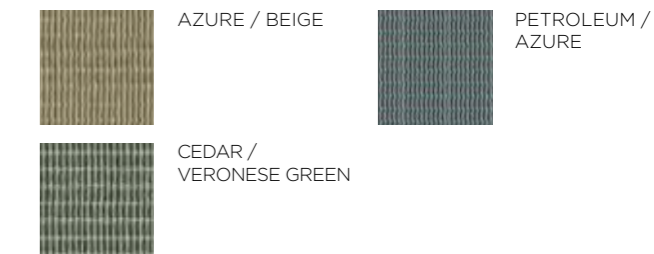

OLIVE GREEN



RIDGE Sand / Steel / Petroleum

WALLCOVERINGS

- PRECIOUS FIBERS 1
- PRECIOUS FIBERS 2
- PRECIOUS FIBERS 3
- REFINED STRUCTURES 1
- REFINED STRUCTURES 2
- GRAPHIC ELEMENTS 1
- GRAPHIC ELEMENTS 2





VERSAILLES Wallcovering/DREAM Bed/COMO Bedside Table/DORY Table Lamp



GION Wallcovering/DREAM Bed/JERRY Bedside Table/DONNA Table Lamp

NABUCCO

PRECIOUS FIBERS 1

“Nabucco” is the popular name of *Nabucodonosor*, one of the greatest operas by the Italian composer Giuseppe Verdi, a milestone of classical music first performed in Milan at La Scala theatre in 1842. To celebrate the deep link of this opera with the history of the city, the wallcovering reproducing Giorgio Armani’s favourite pattern - the streaked texture of onyx slabs - was named after it. Nabucco is also the wallcovering that Mr. Armani chose for the decoration of his boutiques around the world.
MADE IN ITALY.

DIMENSIONS
87 cm - Inch 34.2
Vertical Repeat 150 cm - Inch 59.1

MATERIALS
65% SILK - 35% LUREX
Non-woven base

COLORS

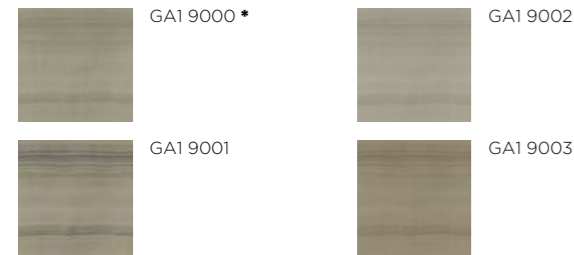

* CODE: GA1 9000

TOSCA

PRECIOUS FIBERS 1

Tosca is a well known opera by the Italian composer Giacomo Puccini, where the action takes place in the majestic city of Rome. The imposing marbles of Roman Empire ruins echo the carved ones of the baroque churches, giving the inspiration for the texture of this precious wallcovering.
MADE IN ITALY.

DIMENSIONS
87 cm - Inch 34.2
Vertical Repeat 150 cm - Inch 59.1

MATERIALS
65% SILK - 35% LUREX
Non-woven base

COLORS

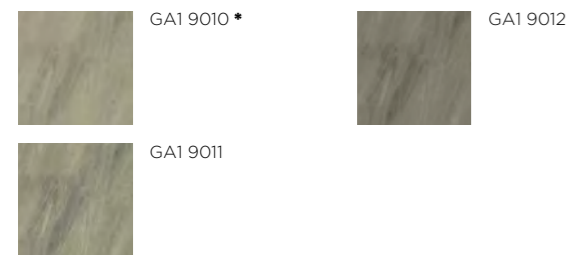

* CODE: GA1 9010

MACBETH

PRECIOUS FIBERS 1

Macbeth is probably one of the most famous plays by William Shakespeare. The compelling history of ambition and betrayal reaches its peak with the well-known episode of the Birnam wood, which seems to “walk” towards Macbeth’s castle decreeing the destiny of the king. The *trompe-l’oeil* wallcovering recalls this event, depicting a forest of deciduous trees with tapestry taste.
MADE IN ITALY.



GA1 9057 GA1 9055 (REPEATING PATTERN) GA1 9056

DIMENSIONS
261x300h cm
Inch 102.7x118.2h

DIMENSIONS
522x300h cm
Inch 205.67x118.2h

DIMENSIONS
261x300h cm
Inch 102.7x118.2h

MATERIALS
65% SILK - 35% LUREX



Plain

PRECIOUS FIBERS 1 - NABUCCO / TOSCA / MACBETH

Eight colours coordinated with Nabucco, Tosca and Macbeth themes. Silk and lurex yarns can create some slight variations on the surface, which must be considered a defining feature of the product.
MADE IN ITALY.

DIMENSIONS
87 cm - Inch 34.2
Vertical Repeat 0 cm - Inch 0

MATERIALS
65% SILK - 35% LUREX
Non-woven base

AIDA

PRECIOUS FIBERS 1

Aida shows a large design depicting palm leaves, immediately recalling the atmosphere of the opera with the same name, set at the time of the Ancient Egypt. The elegant silhouette of the plants is created with tone-on-tone or contrasted colors on a shantung silk base, featuring the typical "knots" in the texture. MADE IN ITALY.

DIMENSIONS

348x300h cm - Inch 137.11x118.2h
Total of four panels

MATERIALS

100% SILK
Non-woven base



COLORS



GA1 9020 *



GA1 9022



GA1 9021

*CODE: GA1 9020 (Repeating Pattern)

Plain

PRECIOUS FIBERS 1 - AIDA
MADE IN ITALY.

DIMENSIONS

87 cm - Inch 34.2
Vertical Repeat 0 cm - Inch 0

MATERIALS

100% SILK
Non-woven base

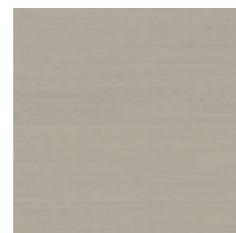

GA1 9070

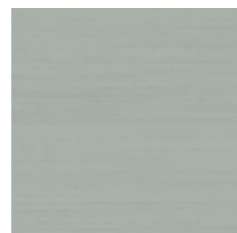

GA1 9071

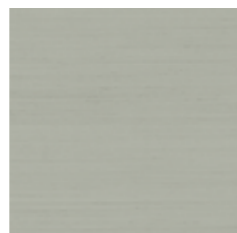

GA1 9072

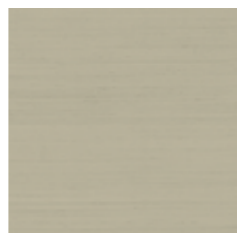

GA1 9073

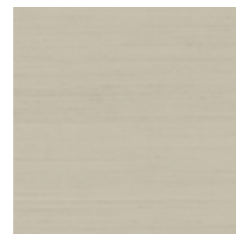

GA1 9074

FAUST

PRECIOUS FIBERS 1

A simple pattern with micro-geometric texture that recalls a shell inlay, but also the lines of music sheets. The Faust wallcovering takes its name from a popular play by the Johann Wolfgang von Goethe, considered one of the greatest works of German literature. MADE IN ITALY.

DIMENSIONS

87 cm - Inch 34.2
Vertical Repeat 50 cm - Inch 19.7

MATERIALS

68% SILK - 32% LUREX
Non-woven base



COLORS

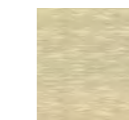

GA1 9040 *



GA1 9042



GA1 9041

*CODE: GA1 9040

Plain

PRECIOUS FIBERS 1 - FAUST
MADE IN ITALY.

DIMENSIONS

87 cm - Inch 34.2
Vertical Repeat 0 cm - Inch 0

MATERIALS

68% SILK - 32% LUREX
Non-woven base



GA1 9090



GA1 9091

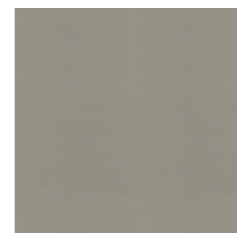

GA1 9092



GA1 9093

OBERON

PRECIOUS FIBERS 1

Oberon owes its name to the Elven king from *A Midsummer's Night Dream* by William Shakespeare. The contrast between appearance and reality is a pivotal element of the plot, and it is the key feature of this wallcovering: a classic Art Déco motif, normally depicted using geometric fan-shaped modules, is actually created by the repetition of a shell silhouette.

MADE IN ITALY.

DIMENSIONS

87 cm - Inch 34.2
Vertical Repeat 21 cm - Inch 8.27

MATERIALS

ramie 24/inch metal yarn 24/inch
Non-woven base



* CODE: GA1 9030

COLORS



GA1 9030 *



GA1 9032



GA1 9031

Plain

PRECIOUS FIBERS 1 - OBERON

MADE IN ITALY.

DIMENSIONS

87 cm - Inch 34.2
Vertical Repeat 0 cm - Inch 0

MATERIALS

ramie 24/inch metal yarn 24/inch
Non-woven base



GA1 9080



GA1 9081

NABUCCO

PRECIOUS FIBERS 2

The most popular and iconic range of wallcoverings by Armani/Casa has been extended with the addition of a horizontal version, which can be enriched by the use of metal profiles. Silk and lurex yarns can create some slight variations on the surface, which must be considered a defining feature of the product.

MADE IN ITALY.

DIMENSIONS

87 h cm - Inch 34.2h
Horizontal Repeat 50 cm - Inch 19.7

MATERIALS

65% SILK - 35% LUREX
Non-woven base

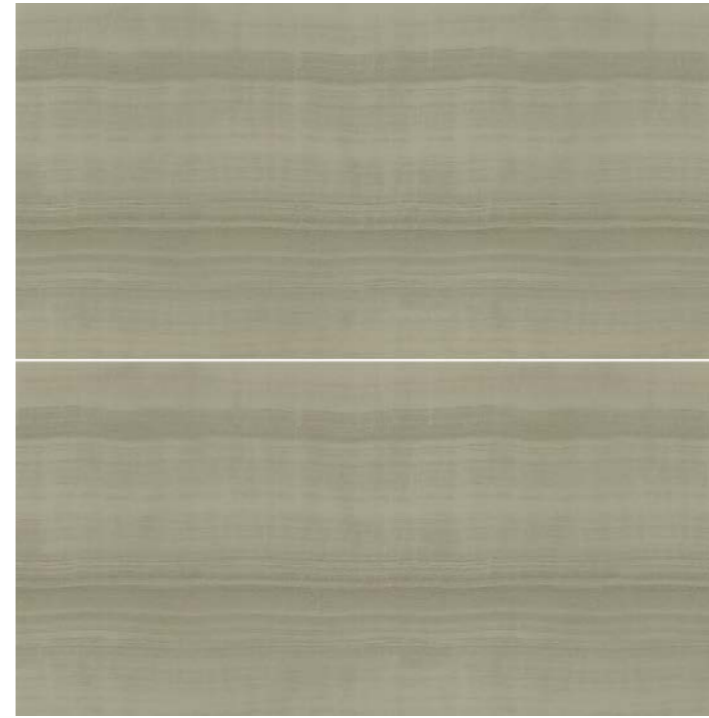

* CODE: GA4 9422

COLORS



GA4 9422 *



GA4 9429



GA4 9424



GA4 9430



GA4 9425



GA4 9431



GA4 9426



GA4 9432



GA4 9427



GA4 9433

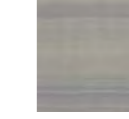

GA4 9428

IOLANTA

PRECIOUS FIBERS 2

Iolanta is a lyric opera by the Russian composer P. Tchaikovsky, where the protagonist is a princess living in a beautiful secret garden. The wallcovering takes inspiration from this dreamlike place, designed with shiny silk in two color combinations: vivid tones of emerald green or delicate shades of pearl grey. MADE IN ITALY.

DIMENSIONS 348x300h cm - Inch 137x118.2h Total of four panels - Repeating Pattern	MATERIALS 65% SILK - 35% LUREX Non-woven base
--	--

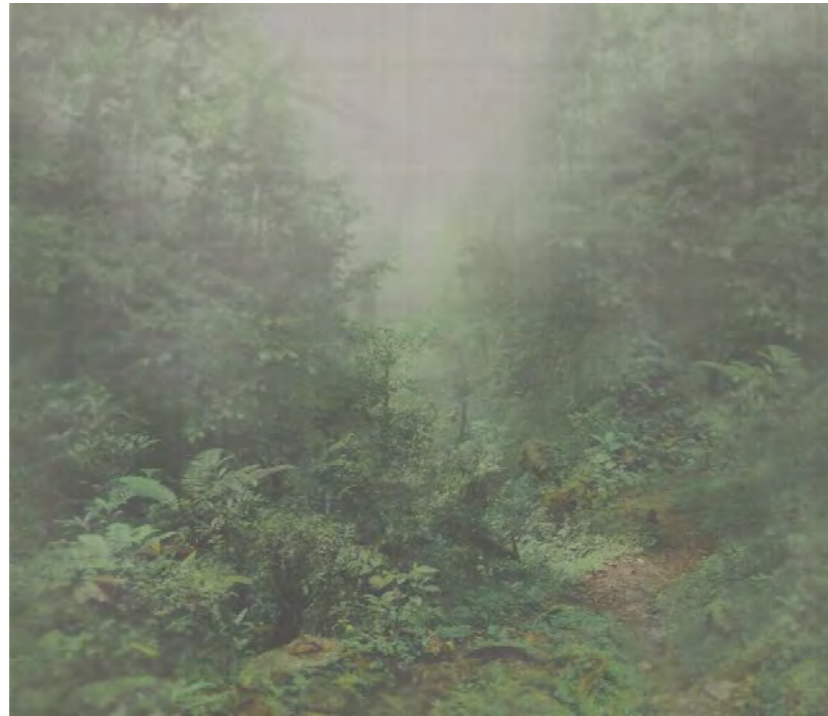

COLORS



*CODE: GA4 9400 (Repeating Pattern)

LOHENGRIN

PRECIOUS FIBERS 2

Fine wallcovering with plissé effect in macro scale. Silk and lurex yarns can create some slight variations on the surface, which must be considered a defining feature of the product. MADE IN ITALY.

DIMENSIONS 87 cm - Inch 34.2 Vertical Repeat 170 cm - Inch 66.92	MATERIALS 65% SILK - 35% LUREX Non-woven base
---	--

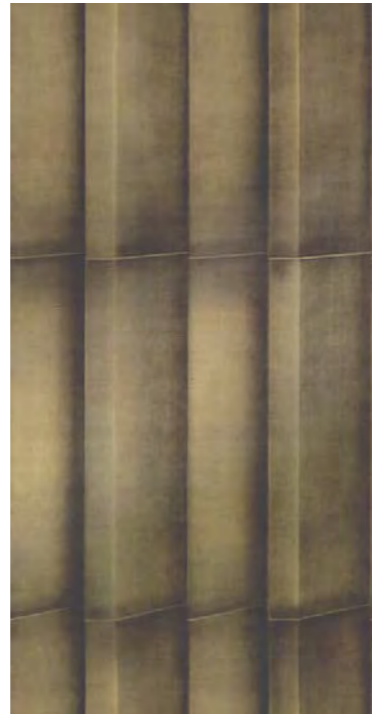

COLORS

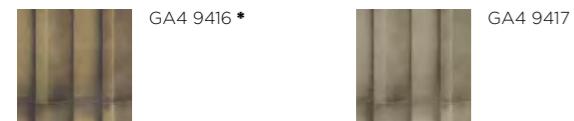

*CODE: GA4 9416

SALOMÈ

PRECIOUS FIBERS 2

Salomè, step-daughter of the famous Herod mentioned in the Bible, is the protagonist of the opera by Richard Strauss with the same name. In this play she performs the famous "*dance of the seven veils*", to which this wallcovering pays a tribute reproducing on the plain background a design created by three-dimensional embroideries in lurex. MADE IN ITALY.

DIMENSIONS 87 cm - Inch 34.2 Vertical Repeat 50 cm - Inch 19.7	MATERIALS 65% SILK - 35% LUREX Non-woven base
---	--



*CODE: GA4 9415



Plain

PRECIOUS FIBERS 2

NABUCCO / IOLANTA / LOHENGRIN / SALOMÈ
Nine colours coordinated with Nabucco, Iolanta, Lohengrin and Salomè themes. Silk and lurex yarns can create some slight variations on the surface, which must be considered a defining feature of the product. MADE IN ITALY.

DIMENSIONS 87 cm - Inch 34.2 Vertical Repeat 0 cm - Inch 0	MATERIALS 65% SILK - 35% LUREX Non-woven base
---	--

BOHÈME

PRECIOUS FIBERS 2

Dedicated to the protagonists of the renowned opera by Giacomo Puccini, *Bohème* incarnates the spirit of the French *cafés* and music halls of the 19th century, places of vibrant life where artists used to meet and find inspiration. The rigorous vertical stripes are interrupted by several irregularities, to add a dandysh feel. MADE IN ITALY.

DIMENSIONS
87 cm - Inch 34.2
Vertical Repeat 50 cm - Inch 19.7

MATERIALS
68% SILK - 32% LUREX
Non-woven base

COLORS



*CODE: GA4 9402

FALSTAFF

PRECIOUS FIBERS 2

Falstaff is the name of a play by Giuseppe Verdi, who took the inspiration from *The Merry Wives of Windsor* by William Shakespeare. Lord Falstaff's joky attitude reflects in the design of this wallcovering, where a tone-on-tone *moiré* effect gives movement to the plain ground. MADE IN ITALY.

DIMENSIONS
87 cm - Inch 34.2
Vertical Repeat 87 cm - Inch 34.2

MATERIALS
68% SILK - 32% LUREX
Non-woven base

COLORS



*CODE: GA4 9409

Plain

PRECIOUS FIBERS 2 - BOHÈME / FALSTAFF

Seven colours coordinated with Bohème and Falstaff themes. Silk and lurex yarns can create some slight variations on the surface, which must be considered a defining feature of the product. MADE IN ITALY.

DIMENSIONS
87 cm - Inch 34.2
Vertical Repeat 0 cm - Inch 0

MATERIALS
68% SILK - 32% LUREX
Non-woven base



Profile

PRECIOUS FIBERS 2

The Precious Fibers 2 collection offers the opportunity to enrich the wallcovering by adding a profile in anodized aluminium, available in two different widths (1 cm and 0,5 cm) for Nabucco - Bohème - Falstaff and one width only (1 cm) for Salomé.

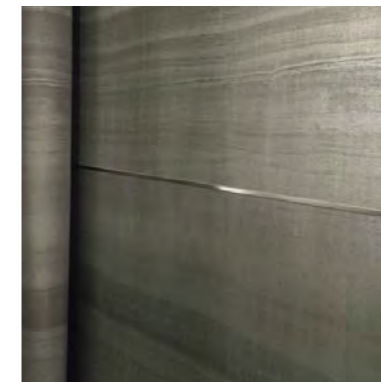

NABUCCO - PROFILE DIMENSION
Anodized Aluminium / Double-sided metal

9470 (Champagne)
1h cm - Inch 0.30

9472 (Champagne)
0,50h cm - Inch 0.20

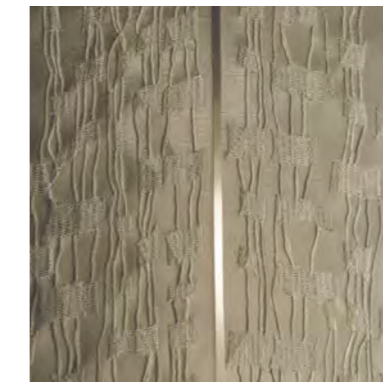

SALOMÉ - PROFILE DIMENSION
Anodized Aluminium / Double-sided metal

9470 (Champagne)
1h cm - Inch 0.30



BOHÈME - PROFILE DIMENSION
Anodized Aluminium / Double-sided metal

9471 (Silver)
1h cm - Inch 0.30

9473 (Silver)
0,50h cm - Inch 0.20

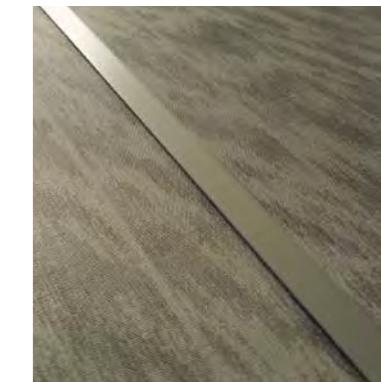

FALSTAFF - PROFILE DIMENSION
Anodized Aluminium / Double-sided metal

9471 (Silver)
1h cm - Inch 0.30

9473 (Silver)
0,50h cm - Inch 0.20

BAYADÈRE

PRECIOUS FIBERS 3

Typical patterns of the folklore are reinterpreted with a contemporary look, with branches and pomegranates printed on a precious Indian silk. The sharp edges and the contrasting colors define shapes and highlight the liveliness of the design. The exotic atmosphere of the décor echoes the famous ballet by Marius Petipa *La Bayadère* (1877), which narrates the story of a young Indian dancer. **MADE IN ITALY.**

DIMENSIONS
87 cm - Inch 34.2
Vertical Repeat 98 cm - Inch 38.6

MATERIALS
70% SILK - 30% LUREX
Non-woven base

COLORS

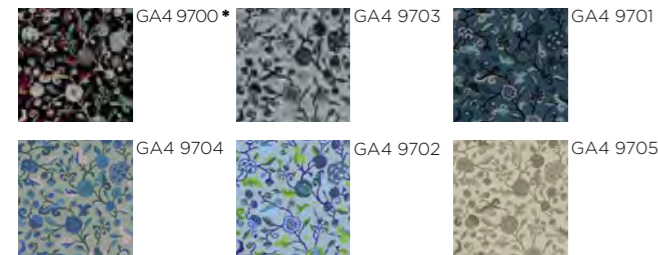

*CODE: GA4 9700

EXCELSIOR

PRECIOUS FIBERS 2

The design of this wallcovering, given by the juxtaposition of multicolored geometric shapes, recalls the reflections and the symmetry created by a kaleidoscope. The meeting between natural light and human invention recalls the theme of the great ballet *Excelsior* (1881) on music by the composer Romualdo Marenco: an allegorical journey where Light guides Civilization towards progress, revealing all inventions and scientific conquests that characterized the XIX century. **MADE IN ITALY.**

DIMENSIONS
87 cm - Inch 34.2
Vertical Repeat 54 cm - Inch 21.2

MATERIALS
70% SILK - 30% LUREX
Non-woven base

COLORS



*CODE: GA4 9710

Plain

**PRECIOUS FIBERS 3
BAYADÈRE / EXCELSIOR**

Plain variants completing the Bayadère and Excelsior ranges. Like the matching wallcoverings, this plain variant is made with raw silk, which features a distinctive textured effect with slubs and knots coming from semi-refined weft yarns. This particular silk is weaved with lurex yarns to enrich the material. **MADE IN ITALY.**

DIMENSIONS
87 cm - Inch 34.2
Vertical Repeat 70 cm - Inch 27.5

MATERIALS
70% SILK - 30% LUREX
Non-woven base



AMAHL

PRECIOUS FIBERS 3

This wallcovering reinterprets a classic animalier motif, featuring crocodile scales, in a modern way and evoking exotic places. The pattern, typical of fashion and luxurious leather goods, becomes the starting point for the rich linen background. The name is a tribute to *Amahl and the Night Visitors* (1951) by the Italian composer Gian Carlo Menotti, which shares with this wallcovering the union of tradition and innovation: in fact, this opera - the first ever conceived for television - presents a plot that changes the usual point of view on the journey of the Magi in the Holy Land. MADE IN ITALY.

DIMENSIONS
87 cm - Inch 34.2
Vertical Repeat 98 cm - Inch 25.2

MATERIALS
100% LINEN
Non-woven base

COLORS



* CODE: GA4 9730

CARMEN

PRECIOUS FIBERS 3

A refined design inspired by pleated fabrics enriches the linen base of this wallcovering. The motif recalls the texture of Giorgio Armani fashion creations, adding dynamism and depth to the tone-on-tone palettes presented in different neutral hues. The name is a tribute to *Carmen* (1875) by George Bizet and the sumptuous decorated dress of Spanish *toreadores* walking the stage of this famous opera. MADE IN ITALY.

DIMENSIONS
87 cm - Inch 34.2
Vertical Repeat 50 cm - Inch 19.7

MATERIALS
100% LINEN
Non-woven base

COLORS



* CODE: GA4 9740

LORELEY

PRECIOUS FIBERS 3

For the making of this wallcovering - dedicated to *Loreley* (1890), opera by Alfredo Catalani - the choice was to use the ancient technique of *fil posé*, made even richer by the use of silk threads, which is rare for this production process. The color palette alternates vivid and pastel tones, neutral gradients and fluid shades inspired by the plot of the opera itself, whose protagonist is a girl turned into a fairy after the wedding to the Rhine river: spells and watery reflections define an oniric atmosphere, celebrated by this wallcovering where the design comes from the reinterpretation of an ikat effect in macro-scale. MADE IN ITALY.

DIMENSIONS
87 cm - Inch 34.2
Vertical Repeat 35 cm - Inch 13.7

MATERIALS
Fil posé - 100% SILK
Non-woven base

COLORS

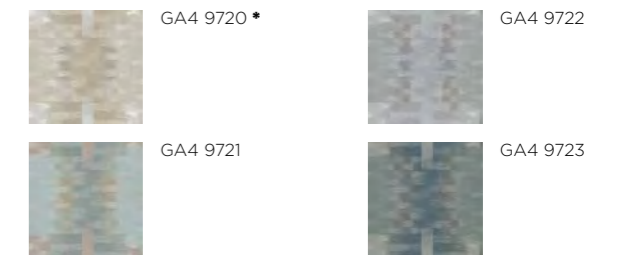

* CODE: GA4 9720

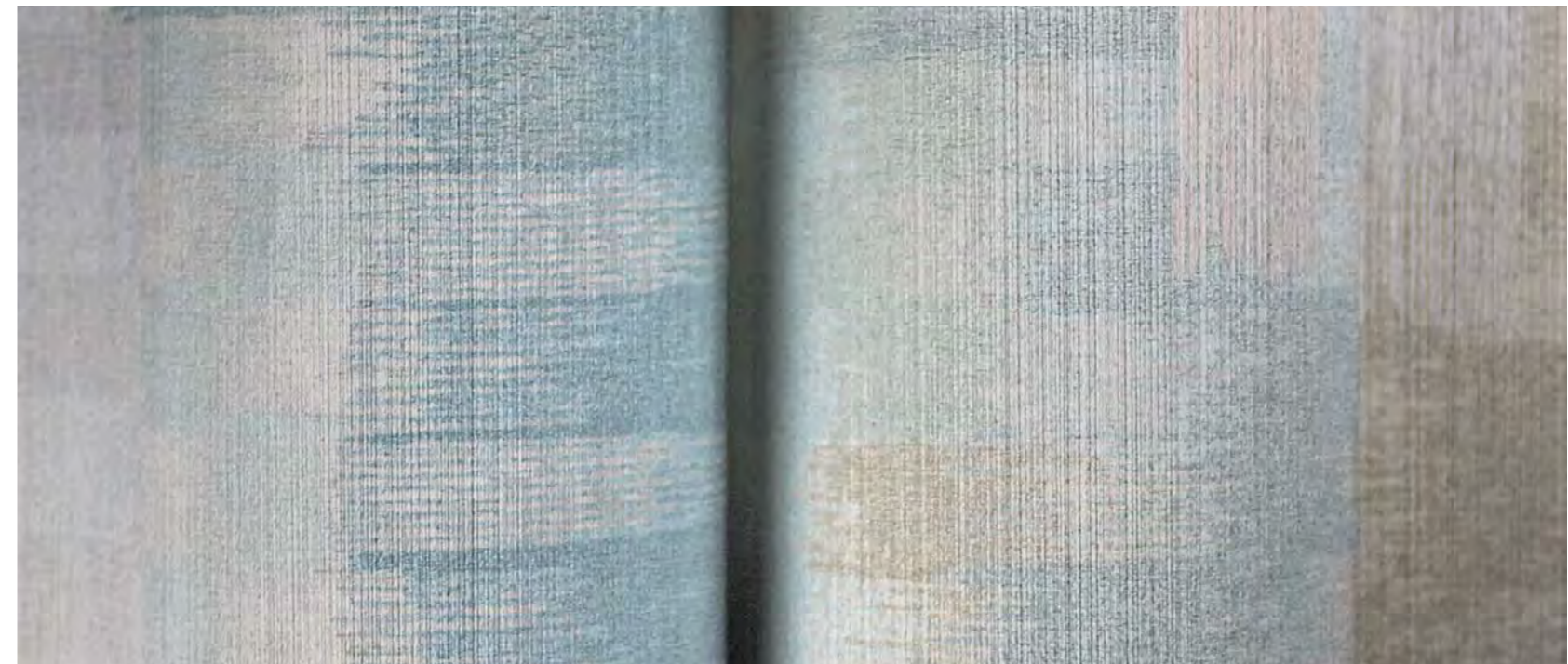

LORELEY Details

COPPÉLIA

PRECIOUS FIBERS 3

The design of this wallcovering, featuring a very realistic *trompe-l'oeil* effect, is taken from the image of a real velvet drapery located in a prestigious historical palace. The marvelous curtain is linked to the one in the enchanted workshop described in the ballet *Coppélia* (1870) by Arthur Saint-Léon, where the eponymous protagonist is a beautiful mechanical doll, whose maker keeps jealously in his shop. Printed on silk/lurex, this wallcovering is completed by a range of rich trimmings developed to emphasize the joints.

MADE IN ITALY.



TOTAL DIMENSIONS
261x300h cm - Inch 102.7x118.2h

MATERIALS
65% SILK - 35% LUREX
Non-woven base

SINGLE PANEL DIMENSIONS
87x300h cm - Inch 34.2x118.2h

COLORS

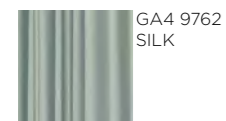
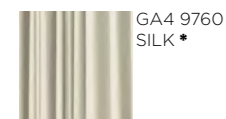

Trimmings

PRECIOUS FIBERS 3 - COPPÉLIA

Flat intertwined trimmings available in three color combinations, developed to enrich the joints of the Coppélia wallcovering. The shiny surface adds another luxurious touch to this detail.

MADE IN ITALY.

DIMENSIONS
7h mm - Inch 0.27h
Length: sold by linear meter

MATERIALS
60% ACRYLIC - 40% COTTON



* CODE: GA4 9760

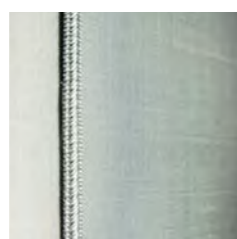

GA7 9795



GA7 9796

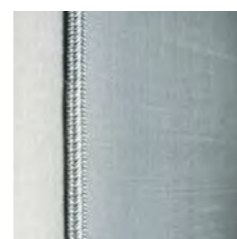

GA7 9797

TURANDOT

PRECIOUS FIBERS 3

The last opera by Giacomo Puccini, *Turandot* (1926), stands out for the setting at the Chinese imperial court. The taste for exotic and the richness of the court are tributed by the design of the wallcovering with the same name, which presents a shagreen motif - a classic of Armani's aesthetics, but also a symbol of prestige and refinement in Eastern countries since the most ancient times - on a silk and lurex background. The texture in relief is obtained thanks an accurate screen printing process directly on silk fibers that uses 3D-expanding inks, an absolute novelty for Armani/Casa.

MADE IN ITALY.



* CODE: GA4 9750

DIMENSIONS
87 cm - Inch 34.2
Vertical Repeat 64 cm - Inch 25.2

MATERIALS
65% SILK - 35% LUREX
Non-woven base

COLORS

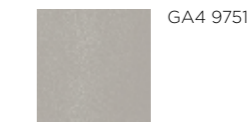
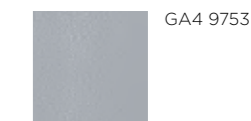
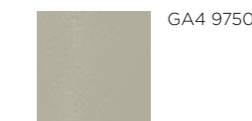

RIGOLETTO

PRECIOUS FIBERS 3

The design of this wallcovering shows an inlay motif presented in an unusual way, where the irregular composition of asymmetrical shapes creates a dynamic and unexpected geometry. The background, made of a precious *mélange* of silk and lurex of exceptional shine, confers more depth. The rich motif takes inspiration by *Rigoletto* (1851) by Giuseppe Verdi, which takes place within the marvelous Palazzo Ducale in Mantua.
MADE IN ITALY.

DIMENSIONS

87x300h cm - Inch 34.2x118.2h
1 drop - Repeating pattern

MATERIALS

65% SILK - 35% LUREX
Non-woven base



* CODE: GA4 9755

COLORS



GA4 9755 *



GA4 9757



GA4 9756



GA4 9770

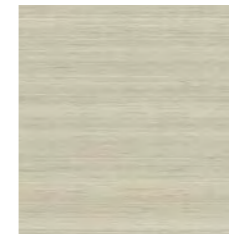

GA4 9771



GA4 9772



GA4 9773



GA4 9774



GA4 9775



GA4 9776



GA4 9777



GA4 9778



GA4 9779

Plain

PRECIOUS FIBERS 3

COPPÉLIA / RIGOLETTO / TURANDOT

Plain variants perfectly matching the silk of Coppélia, Rigoletto and Turandot wallcoverings. Silk and lurex yarns can create some slight variations on the surface.
MADE IN ITALY.

DIMENSIONS

87 cm - Inch 34.2
Vertical Repeat 70 cm - Inch 27.5

MATERIALS

65% SILK - 35% LUREX
Non-woven base

LOUVRE

REFINED STRUCTURES 1

Louvre takes its name from the famous royal palace located in the heart of Paris: Armani/Casa dedicates to this remarkable residence the wallcovering featuring one of the most iconic Giorgio Armani's motifs, the *canneté*. This wallcovering can be used both vertically and horizontally.

MADE IN ITALY.

DIMENSIONS 70 cm - Inch 27.56 Vertical Repeat 0 cm - Inch 0	MATERIALS 100% Vinyl Non-woven base
--	--

COLORS

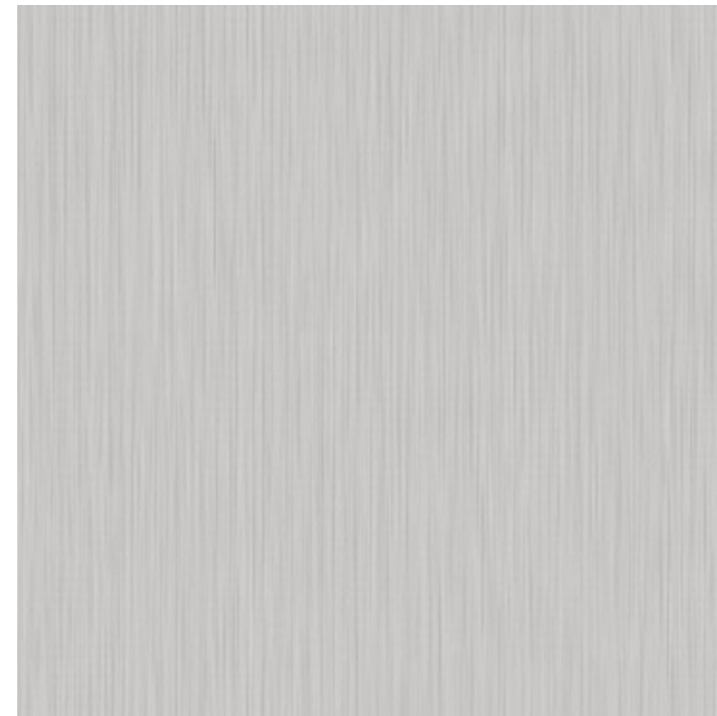

* CODE: GA2 9200

MONTMARTRE

REFINED STRUCTURES 1

Montmartre is a Parisian neighbourhood defined by two different yet complementary sides: a holy one, represented by the white dome overlooking the city, and a profane one, due to the eccentric artists that lived in the area during the 19th century. This dichotomy echoes in the wallcovering with the same name, where a checkered motif is coupled with a shagreen leather print.

MADE IN ITALY.

DIMENSIONS 70 cm - Inch 27.56 Vertical Repeat 60 cm - Inch 23.6	MATERIALS 100% Vinyl Non-woven base
--	--

COLORS

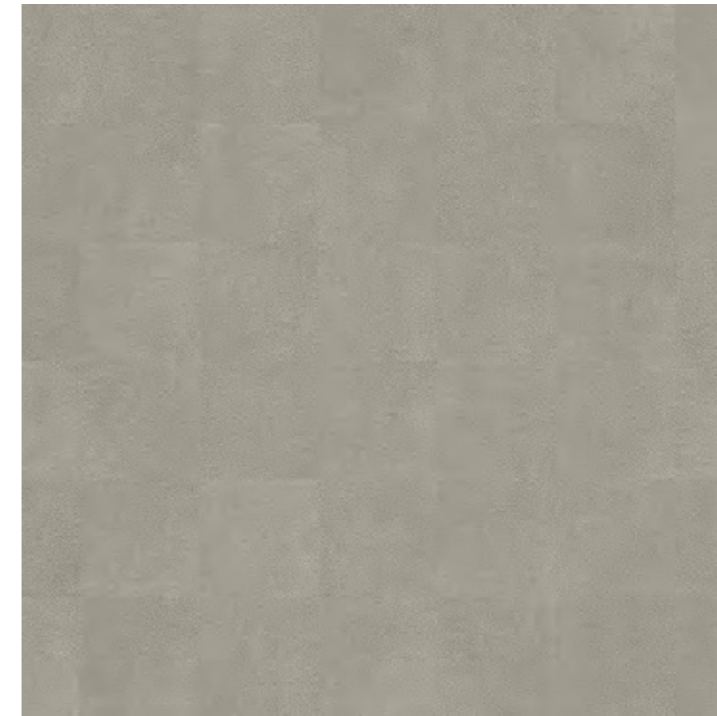

* CODE: GA2 9220

MADELEINE

REFINED STRUCTURES 1

The Madeleine is an imposing church in Paris, built in the 19th century with a clear Greek inspiration, where marble columns, statues and reliefs complete the austere neat look. In the same way the acanthus plant was used in reliefs as a decorative motif, this wallcovering features stylized leafy branches that add rhythm to the solid background.

MADE IN ITALY.

DIMENSIONS 70 cm - Inch 27.56 Vertical Repeat 60 cm - Inch 23.6	MATERIALS 100% Vinyl Non-woven base
--	--

COLORS

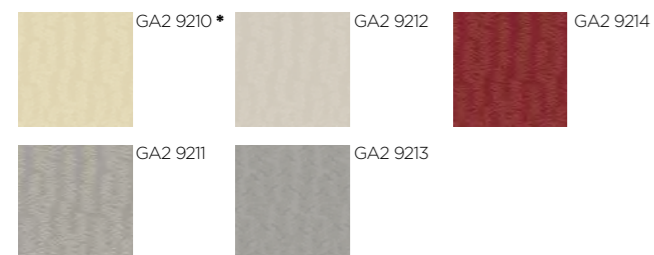

* CODE: GA2 9210

OPÉRA

REFINED STRUCTURES 1

The Opéra Garnier is the most prestigious theatre in Paris: a building that is a triumph of opulence, rich in gold, brocade and luxurious chandeliers. The *Opéra* wallcovering pays tribute to this temple of music thanks to the *canneté* stripes alternating with the plain background, which remind the lines of a pentagram drawn on a paper sheet. Due to the design, this wallcovering can be used both vertically and horizontally.

MADE IN ITALY.

DIMENSIONS 70 cm - Inch 27.56 Vertical Repeat 0 cm - Inch 0	MATERIALS 100% Vinyl Non-woven base
--	--

COLORS

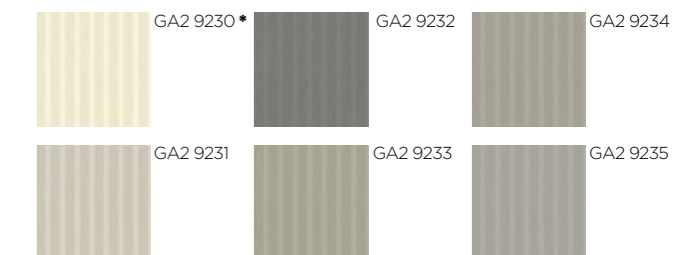

* CODE: GA2 9230

PANTHEON

REFINED STRUCTURES 1

The Panthéon is a church hosting the tombs of many important French citizens since the 18th centuries: artists, writers, scientists, politicians. Armani/Casa dedicated this wallcovering to this important location by reinterpreting an icon Armani motif, the checked pattern.

MADE IN ITALY.

DIMENSIONS
70 cm - Inch 27.56
Vertical Repeat 70 cm - Inch 27.56

MATERIALS
100% Vinyl
Non-woven base

COLORS

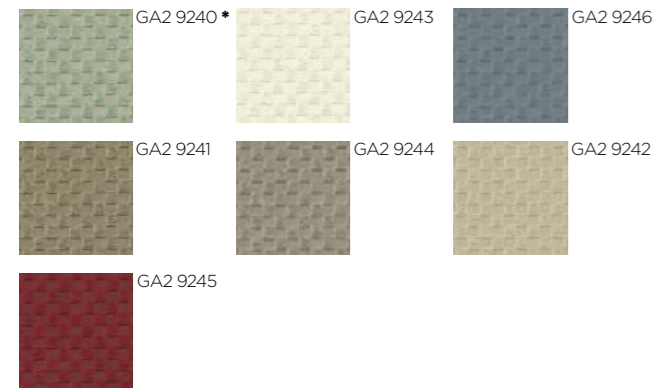

* CODE: GA2 9240

TROCADERO

REFINED STRUCTURES 1

Place du Trocadéro is a square located in Paris, which is part of a complex comprising gardens and fountains with a stunning view on France's most famous monuments, the Eiffel tower. This wallcovering shows a typical Armani pattern, an animalier motif developed with a micro crocodile scale module.

MADE IN ITALY.

DIMENSIONS
70 cm - Inch 27.56
Vertical Repeat 70 cm - Inch 27.56

MATERIALS
100% Vinyl
Non-woven base

COLORS

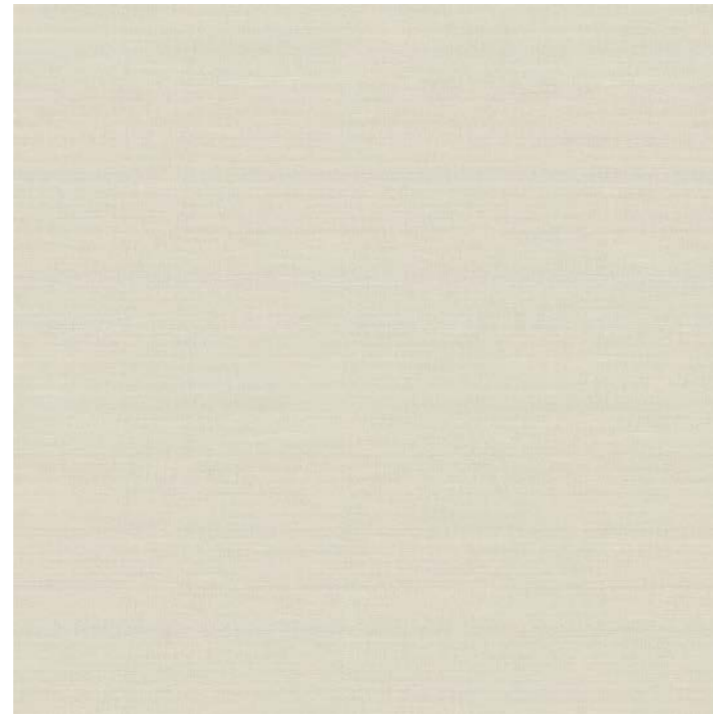

* CODE: GA2 9250

VERSAILLES

REFINED STRUCTURES 1 - 2

The French village of Versailles immediately evokes a world of luxury and preciousness thanks to its suggestive castle, which king Louis XIV brought to the maximum radiance in the XVII century. This exceptional residence is a collection of authentic masterpieces, including the majestic gardens that surround the buildings. This range of bestselling wallcoverings of the same name is inspired by the shade of royal oaks depicted with a fresco effect.

MADE IN ITALY.

DIMENSIONS
70 cm - Inch 27.56
Vertical Repeat 95 cm - Inch 37.4

MATERIALS
100% Vinyl
Non-woven base



* CODE: GA2 9260

COLORS REFINED STRUCTURES 1



COLORS REFINED STRUCTURES 2



BRERA

REFINED STRUCTURES 2

Brera, "the district of the artists", is the most renowned of Milan: located in the heart of the historic city center, it is famous for its art academy, the charming atmosphere and fine boutiques. The same elegance defines this wallcovering, inspired by the details of the Armani Privé collections. The design created by the embroidering of thousands of beads is reproduced on the vinyl support, made precious by the use of a pearlescent finishing that highlights the three-dimensional effect. Presented in neutral tones as well as pastel blue and green.
MADE IN ITALY.

DIMENSIONS

70 cm - Inch 27.56

Vertical Repeat 16 cm - Inch 6.3

MATERIALS

100% Vinyl

Non-woven base

COLORS



* CODE: GA5 9510

MARAIS

REFINED STRUCTURES 2

The Parisian neighborhood of Le Marais is one of a kind: located in the heart of the city, it has maintained untouched its ancient look together with the charm of a place where, thanks to the mix of different inspirations and suggestions, ideas and fashion trends are constantly born. This creative dynamism inspired this wallcovering: the trompe-l'oeil effect imitates the drapery of a light fabric of many veils by Giorgio Armani, almost impalpable, which defines an elegant palette of neutral tones, as well as pastel blue and green.
MADE IN ITALY.

DIMENSIONS

68 cm - Inch 26.77

Vertical Repeat 80 cm - Inch 31.5

MATERIALS

100% Vinyl

Non-woven base

COLORS



* CODE: GA5 9550

SAINT GERMAIN

REFINED STRUCTURES 2

The eclectic neighborhood of Saint-Germain has always been the meeting point of intellectuals, the birthplace of modern French literature and philosophy; in time, the district has also become the prestigious home of the most luxurious boutiques worldwide. The synthesis of this dichotomy echoes in this wallcovering, which combines an irregular checkers scheme with an off-centered sun motif, inspired by the straw marquetry. The reinterpretation of iconic Armani/Casa elements is a theme in continuous evolution but always consistent with its own essence, just like Paris, the city to which this paper is dedicated. Presented in neutral tones as well as pastel blue and green.
MADE IN ITALY.

DIMENSIONS

70 cm - Inch 27.56

Vertical Repeat 23 cm - Inch 20.9

MATERIALS

100% Vinyl

Non-woven base

COLORS

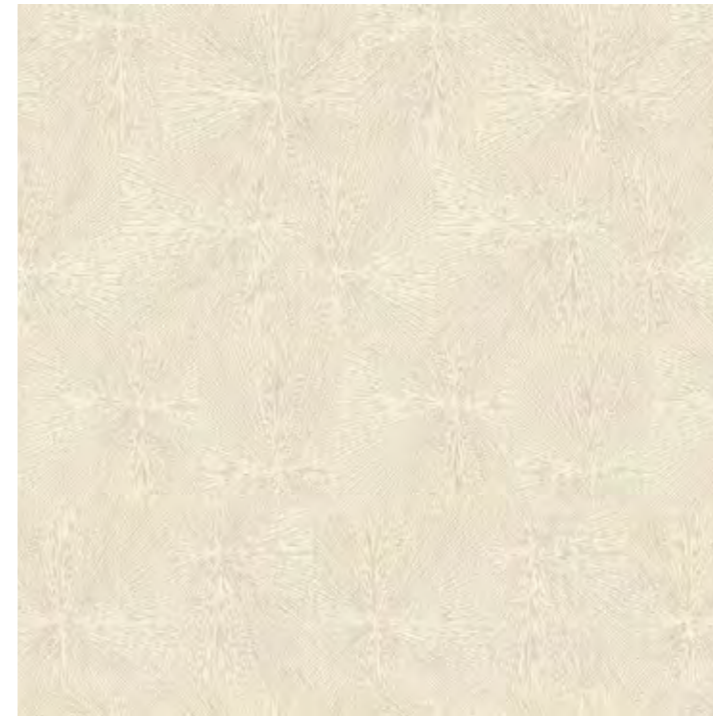

* CODE: GA5 9520

GINZA

REFINED STRUCTURES 2

Ginza is the most glamorous district of Tokyo, a place where Eastern traditions are continuously reinterpreted to embrace modernity and the vertical development of buildings. In the same way, this wallcovering takes inspiration from the texture of Japanese tatami carpets to obtain a paper suitable for the wall decoration. Presented in twelve variations with three-dimensional effect, four of which enriched by a shiny finishing. MADE IN ITALY.

DIMENSIONS
70 cm - Inch 27.56
Vertical Repeat 64 cm - Inch 25.2

MATERIALS
100% Vinyl
Non-woven base



* CODE: GA5 9530

COLORS



GION

REFINED STRUCTURES 2

Gion is a place where time does not seem to pass: this district of Kyoto, one of Japan's most ancient cities, is known for the mysterious geishas that live there still nowadays. The wooden buildings and the mystic temples are surrounded by peaceful zen gardens, recalled by the pattern of this wallcovering depicting bamboo trees in large scale. The original design is inspired by the richness of jacquard fabrics by Armani/Casa. Presented in six pastel and natural tones combinations. MADE IN ITALY.

DIMENSIONS
200 cm - Inch 39.37
Vertical Repeat 53 cm - Inch 20.9

MATERIALS
100% Vinyl
Non-woven base



* CODE: GA5 9500

COLORS

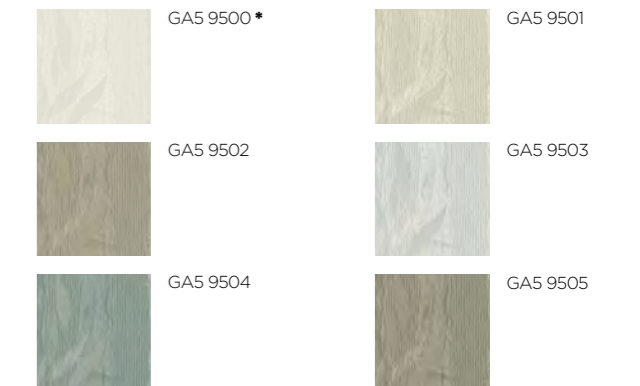

BELGRAVIA

REFINED STRUCTURES 2

The borough of Belgravia, in London, is famous for the white palaces in Neoclassical style that express a mood of rigorous elegance. The seeming simplicity of the architecture, which appears at first glance, is actually a dynamic series of marbles and stuccos, statues and decorative motifs. This wallcovering follows this concept of "unexpected detail": the background, based on a play of large tiles of streaked marble, is crossed horizontally at the top and at the bottom by a contrasting frame with chevron motif. Once more, the wallcovering becomes the occasion to transform key elements of the Armani style like stones and the textile design. The range is coordinated with a printed version with marble tiles only. MADE IN ITALY.

DIMENSIONS 136x300h cm - Inch 53.5x 118.2h Repeating Pattern 136 cm - Inch 53.5	MATERIALS 100% Vinyl Non-woven base
--	--

COLORS

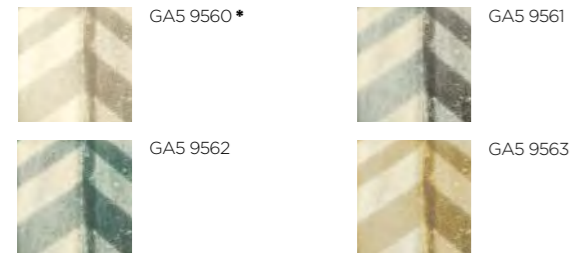

* CODE: GA5 9560

Plain

PRECIOUS FIBERS 2 - BELGRAVIA

Three colors coordinated with the Belgravia theme, printed with the marble tiles design only. MADE IN ITALY.

DIMENSIONS 68 cm - Inch 26.77 Vertical Repeat 140 cm - Inch 55.11	MATERIALS 100% Vinyl Non-woven base
--	--

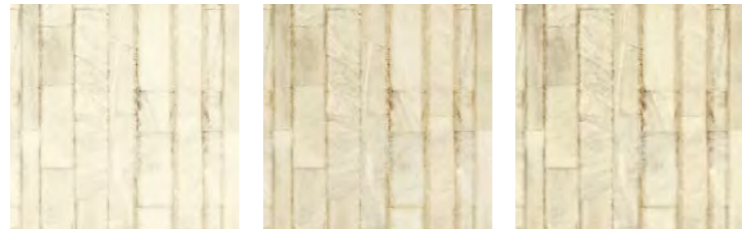

GA5 9580 GA5 9581 GA5 9582

KENSINGTON

REFINED STRUCTURES 2

Kensington is a variation on the theme of Belgravia, since it features the same marble background and the chevron motif in half scale. The major difference, though, is that on Kensington the chevron is repeated every 53 cm on the full height of the wallcovering. The range is coordinated with a printed version with marble tiles only. MADE IN ITALY.

DIMENSIONS 70 cm - Inch 27.56 Vertical Repeat 53 cm - Inch 20.9	MATERIALS 100% Vinyl Non-woven base
--	--

COLORS

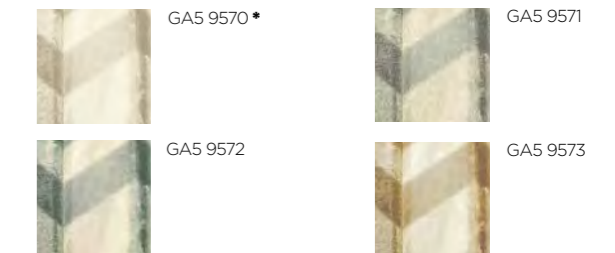

* CODE: GA5 9570

Plain

PRECIOUS FIBERS 2 - KENSINGTON

Three colors coordinated with the Kensington theme, printed with the marble tiles design only. MADE IN ITALY.

DIMENSIONS 70 cm - Inch 26.77 Vertical Repeat 70 cm - Inch 27.56	MATERIALS 100% Vinyl Non-woven base
---	--

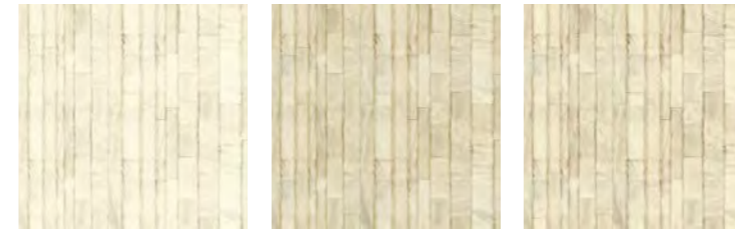

GA5 9590 GA5 9591 GA5 9592

HIMALAYA METALLIZED

GRAPHIC ELEMENTS 1

This wallcovering is inspired by traditional Japanese kimonos, characterised by a wide gradient on triangular shapes recalling the snowy peaks of Himalaya mountains. Made on metal support lined with a fine non-woven fabric mesh. MADE IN ITALY.

DIMENSIONS
68 cm - Inch 26.77
Vertical Repeat 64 cm - Inch 25.2

MATERIALS
Metallized
Non-woven base

COLORS



* CODE: GA3 9330

TOWADA METALLIZED

GRAPHIC ELEMENTS 1

Wallcovering featuring macro and micro variations of a pattern inspired by Japanese tsubas (guards of *katana* swords). Available on metal support lined with a fine non-woven fabric mesh, the palette comprises neutral hues as well as vivid tones taken by the colors of Towada lake in autumn. MADE IN ITALY.

DIMENSIONS
68 cm - Inch 26.77
Vertical Repeat 64 cm - Inch 25.2

MATERIALS
Metallized
Non-woven base

COLORS

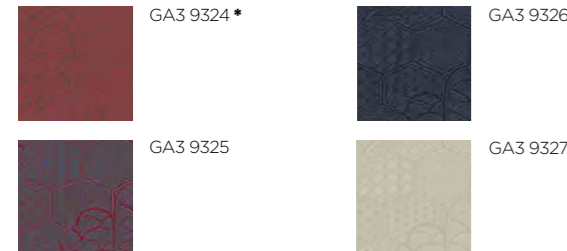

* CODE: GA3 9324

Plain Metallized

METALLIZED - HIMALAYA / TOWADA

Six colours coordinated with Himalaya and Towada themes on metallic support. MADE IN ITALY.

DIMENSIONS
68 cm - Inch 26.77
Vertical Repeat 0 cm - Inch 0

MATERIALS
Metallized
Non-woven base



TOWADA METALLIZED Details

FUJI

GRAPHIC ELEMENTS 1

This wallcovering is dedicated to mount Fuji, the symbol of Japan. The design shows a stylized Japanese garden in spring, featuring cherry blossoms filtered by a rigorous architecture to express the blend of East and West. Made on a non-woven fabric with a metal laminate, to create a pearlescent effect. MADE IN ITALY.

DIMENSIONS 70 cm - Inch 27.55 Vertical Repeat 35 cm - Inch 13.8	MATERIALS Vinyl metallic Non-woven base
--	--

COLORS

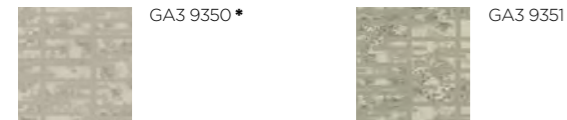

* CODE: GA3 9350

JAVA

GRAPHIC ELEMENTS 1

The recurring checker motif of Armani/Casa is reinterpreted using a geometric weave with a three-dimensional effect: all the squares show a distinctive *canneté* design, an Armani/Casa classic, which also reminds of the rocky slopes on Java island. Made on a non-woven fabric base with metal laminate, to create a pearlescent effect. MADE IN ITALY.

DIMENSIONS 70 cm - Inch 27.55 Vertical Repeat 35 cm - Inch 13.8	MATERIALS Vinyl metallic Non-woven base
--	--

COLORS

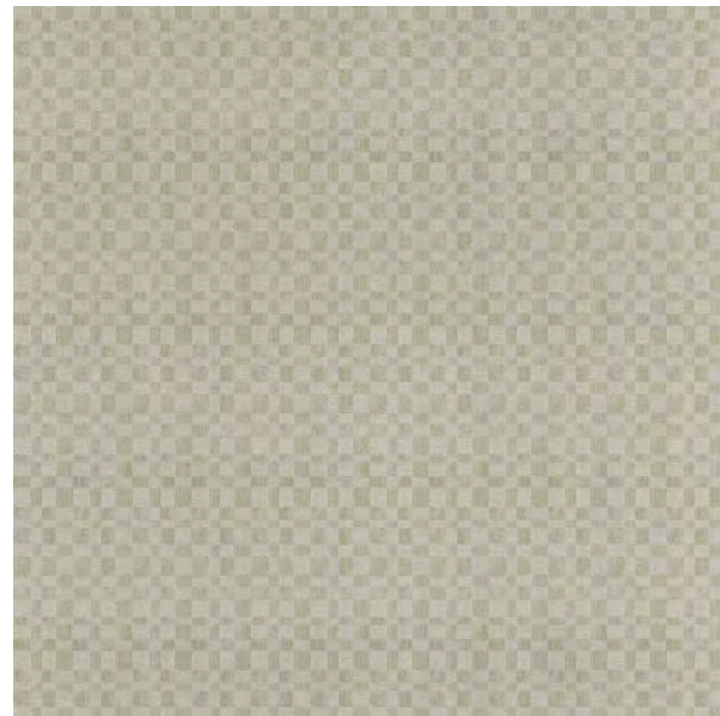
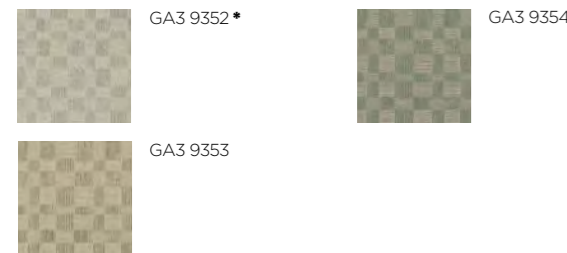

* CODE: GA3 9352

Plain Vinyl Metallic

VINYL METALLIC - FUJI / JAVA

Four colours coordinated with Fuji and Java themes on Vinyl metallic support. MADE IN ITALY.

DIMENSIONS 70 cm - Inch 27.5 Vertical Repeat 0 cm - Inch 0	MATERIALS Vinyl metallic Non-woven base
---	--



JAVA Details

HIMALAYA RAFFIA

GRAPHIC ELEMENTS 1

This wallcovering is inspired by traditional Japanese kimonos, characterised by a wide gradient on triangular shapes recalling the snowy peaks of Himalaya mountains. Made on raffia support. MADE IN ITALY.

DIMENSIONS

87 cm - Inch 34.2
Vertical Repeat 87 cm - Inch 34.2

MATERIALS

Raffia
Non-woven base

COLORS



* CODE: GA3 9333

SAGANO

GRAPHIC ELEMENTS 1

Bamboo, an iconic element of Armani/Casa, is revisited in a geometric version refined by a subtly nuanced effect. The name echoes the Sagano bamboo forest, in Kyoto, a mystic place of supernatural beauty and quiet. Made on a raffia support. MADE IN ITALY.

DIMENSIONS

87 cm - Inch 34.2
Vertical Repeat 16 cm - Inch 6.2

MATERIALS

Raffia
Non-woven base

COLORS

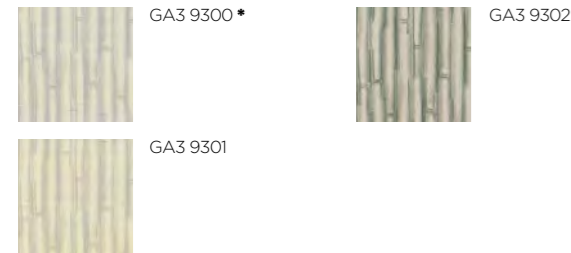

* CODE: GA3 9300

SUMATRA

GRAPHIC ELEMENTS 1

A continuous motif with trees and tigers reinterprets a design inspired by traditional Japanese *tsubas* (guards of *katana* swords). The choice of depicting plants and wild animals recalls the savage landscape of Sumatra island. Made on a raffia support. MADE IN ITALY.

DIMENSIONS

87 cm - Inch 34.2
Vertical Repeat 35 cm - Inch 34.2

MATERIALS

Raffia
Non-woven base

COLORS

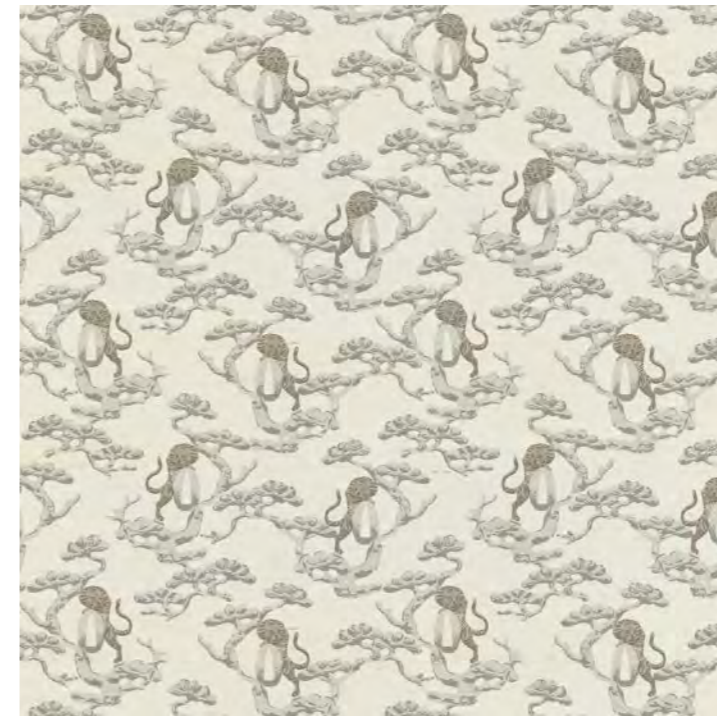
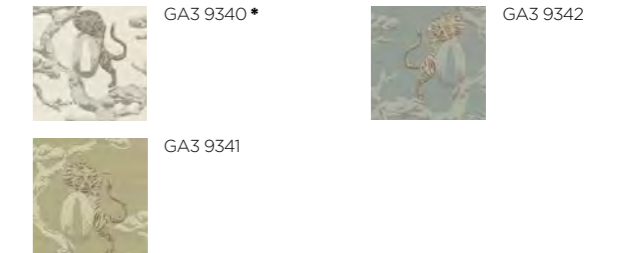

* CODE: GA3 9340



Plain

RAFFIA - HIMALAYA RAFFIA / SAGANO / SUMATRA

Eight colours coordinated with Himalaya Raffia, Sagano and Sumatra themes on raffia support. MADE IN ITALY.

DIMENSIONS

87 cm - Inch 34.2
Vertical Repeat 0 cm - Inch 0

MATERIALS

Raffia
Non-woven base

TOWADA FIL

GRAPHIC ELEMENTS 1

Wallcovering featuring macro and micro variations of a pattern inspired by Japanese tsubas (guards of katana swords). Available on raffia support, the palette comprises neutral hues as well as vivid tones taken by the colors of Towada lake in autumn. MADE IN ITALY.

DIMENSIONS
70 cm - Inch 27.5
Vertical Repeat 64 cm - Inch 25.2

MATERIALS
Fil posé
Non-woven base



COLORS



* CODE: GA3 9320

NIAGARA

GRAPHIC ELEMENTS 1

Wallcovering made on fabric support, featuring a chevron motif. This texture, recurring element of the Giorgio Armani style, is deconstructed to create a particular discontinuous geometry; the pointy elements add a vertical movement to the composition, imitating the majestic falls on the Niagara river. MADE IN ITALY.

DIMENSIONS
70 cm - Inch 27.5
Vertical Repeat 64 cm - Inch 25.2

MATERIALS
Fil posé
Non-woven base

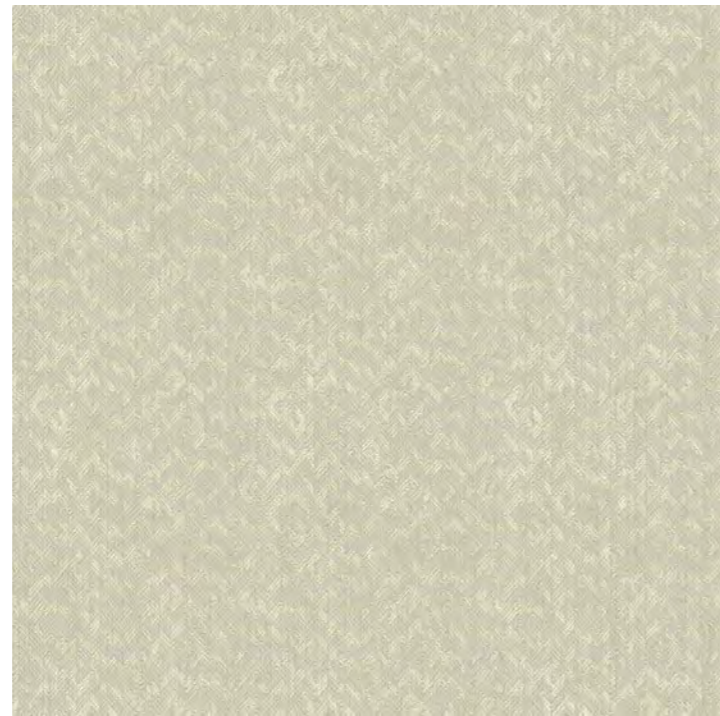

COLORS



* CODE: GA3 9310

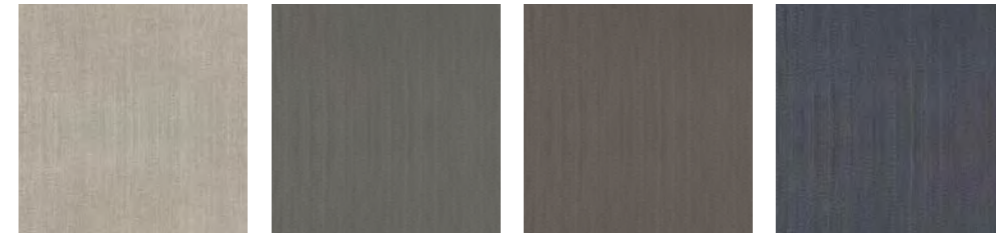

GA3 9370 GA3 9371 GA3 9372 GA3 9373

Plain

FIL POSÉ - NIAGARA / TOWADA FIL

Four colours coordinated with Niagara and Towada Fil on fabric support. MADE IN ITALY.

DIMENSIONS
70 cm - Inch 27.5
Vertical Repeat 0 cm - Inch 0

MATERIALS
Fil posé
Non-woven base



NIAGARA Details

ELBA

GRAPHIC ELEMENTS 2

The isle of Elba, off the Tuscan shores, presents an extremely variegated landscape, interrupted by the famous mineral mines. The typical shades and reflections of tourmaline, beryl and garnet crystals of the island are reproduced with a *moiré* effect on the surface of this wallcovering, made with the *fil posé* technique to add a touch of luster.

MADE IN ITALY.

DIMENSIONS

70 cm - Inch 27.5
Vertical Repeat 64 cm - Inch 25.2

MATERIALS

Fil Posé
Non-woven base



*CODE: GA6 9630

COLORS



LIPARI

GRAPHIC ELEMENTS 2

Lipari is the largest of the Aeolian islands, seven gems sprinkled in the blue of the Mediterranean Sea and located not far from the shores of Sicily. The name of the island echoes its beauty and the richness, coming from the ancient Greek Lipàra, which means "fruitful". For its prominent position in the archipelago, the wallcovering featuring one of the most iconic designs of the Armani style, the shagreen texture, has been named after this island.

MADE IN ITALY.

DIMENSIONS

90 cm - Inch 35.5
Vertical Repeat 50 cm - Inch 19.68

MATERIALS

Non-woven base

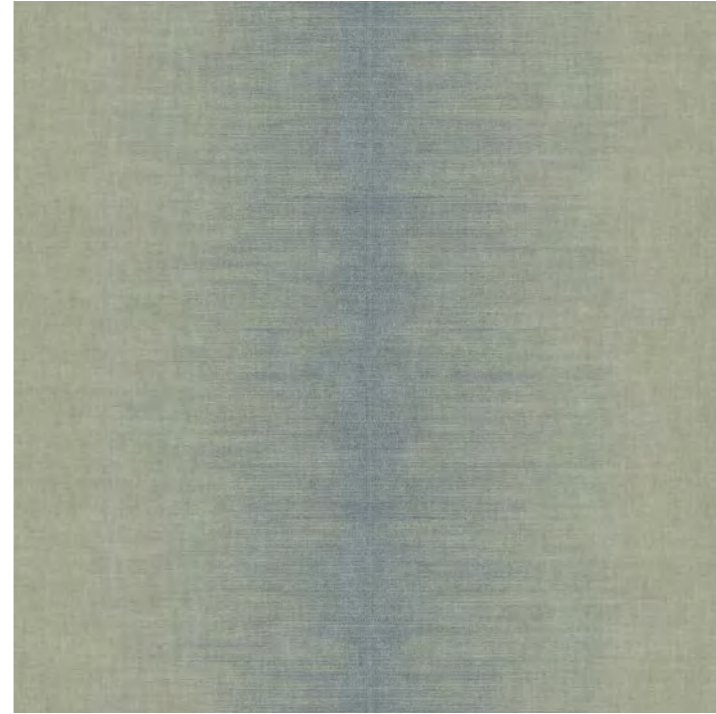

*CODE: GA6 9621

COLORS



MURANO

GRAPHIC ELEMENTS 2

This island, located in the heart of the Venetian lagoon, is the place where glass masters carry on the tradition of glass blowing for many centuries. The skill of artisans has become famous worldwide, thanks to masterpieces like the marvelous chandeliers that once decorated noble palaces in the whole Europe. The atmosphere of ball halls and galleries lit by their sparkling lights is reproduced by this wallcovering, which shows a vintage effect inspired by the walls of those rooms.

MADE IN ITALY.

DIMENSIONS

90 cm - Inch 35.5
Vertical Repeat 90 cm - Inch 35.5

MATERIALS

Non-woven base

COLORS

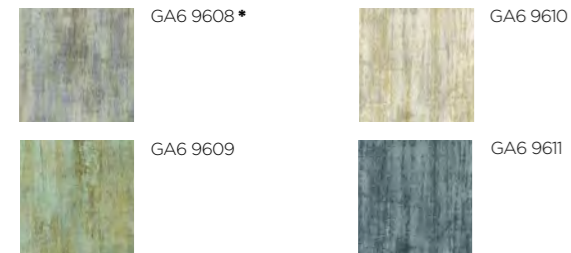

* CODE: GA6 9608

PANTELLERIA

GRAPHIC ELEMENTS 2

One of Giorgio Armani's favorite islands, Pantelleria was known in the past as "Daughter of the Winds" because of the strong breeze always blowing. The wild landscapes of the island are studded with typical constructions called *panteschi* gardens, cylinders made with stone blocks to protect the citrus trees. These two sides of Pantelleria are reflected in the wallcovering of the same name, where an irregular design recalls the stone effect on a background imitating the waves the wind creates on the surface of the sea.

MADE IN ITALY.

DIMENSIONS

90 cm - Inch 35.5
Vertical Repeat 25 cm - Inch 9.84

MATERIALS

Non-woven base

COLORS

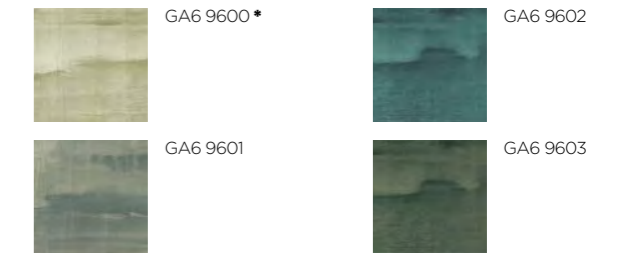

* CODE: GA6 9600

PANAREA

GRAPHIC ELEMENTS 2

Panarea is the smallest of the Aeolian islands, a paradise defined by a sort of wild landscape and lifestyle to discover, highly appreciated by the international jet set. The very idea of hidden yet refined luxury inspired this wallcovering, showing a plissé design with a *trompe-l'oeil* effect.

MADE IN ITALY.

DIMENSIONS

90 cm - Inch 35.5
Vertical Repeat 90 cm - Inch 35.5

MATERIALS

Non-woven base

COLORS

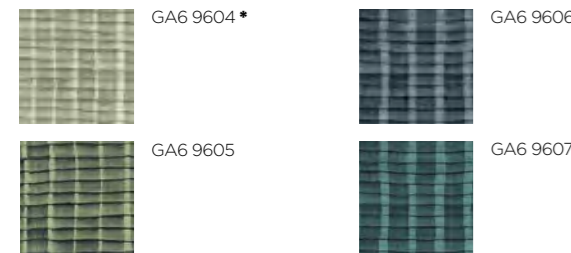

* CODE: GA6 9604

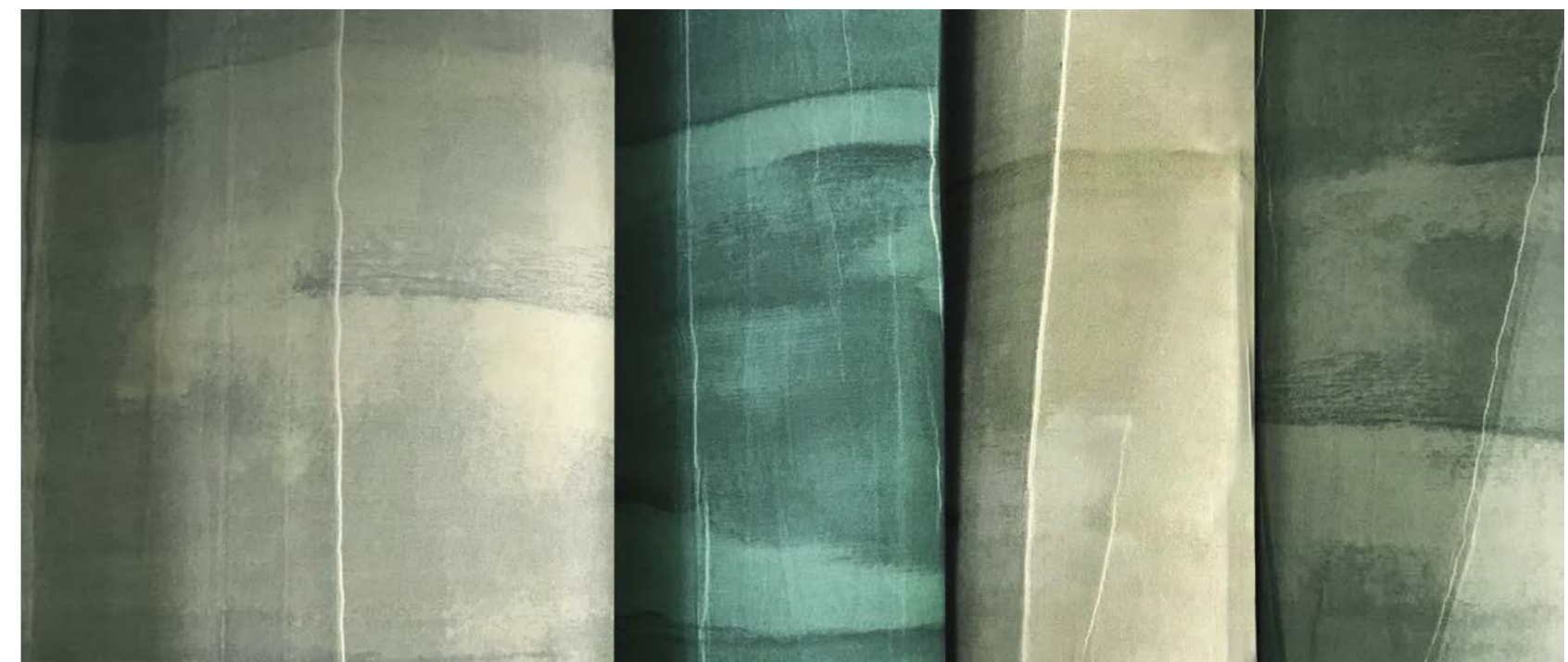

PANTELLERIA Details

PONZA

GRAPHIC ELEMENTS 2

Ponza is famous for its jagged shores, rich in rocks and cliffs overlooking the sea. Located not too far from Rome, it was chosen as the location for some patricians' villas, defined by a geometric and austere look reflecting the harsh nature of the island. The strong presence of squared lines is replicated also on the wallcovering, showing a deconstructed checkered design in many color variations.
MADE IN ITALY.

DIMENSIONS 87 cm - Inch 34.2 Vertical Repeat 12 cm - Inch 4.72	MATERIALS Linen Non-woven base
---	---

COLORS

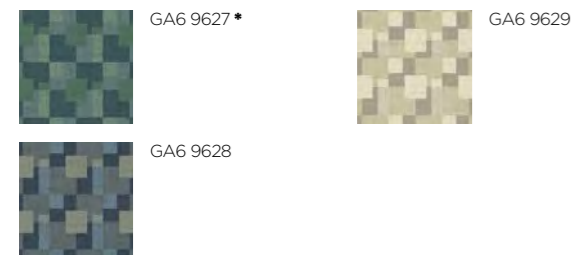

* CODE: GA6 9627



Plain

LINEN - CAPRI / PONZA

Five colours coordinated with Capri and Ponza on linen support.
MADE IN ITALY.

DIMENSIONS 87 cm - Inch 34.2 Vertical Repeat 0 cm - Inch 0	MATERIALS Linen Non-woven base
---	---

CAPRI

GRAPHIC ELEMENTS 2

The island of Capri, famous for being a favorite destination of celebrities from all over the world, is actually full of natural beauties: the imposing *faraglioni*, for example, typical rock formations emerging from the sea like pinnacles, or the *Grotta Azzurra*, a cave known for its charming blue reflections. The design of this wallcovering recalls the union of glamour and nature, featuring textile geometries on a floral background.
MADE IN ITALY.

DIMENSIONS 87 cm - Inch 34.2 Vertical Repeat 66 cm - Inch 25.98	MATERIALS Linen Non-woven base
--	---

COLORS



* CODE: GA6 9612

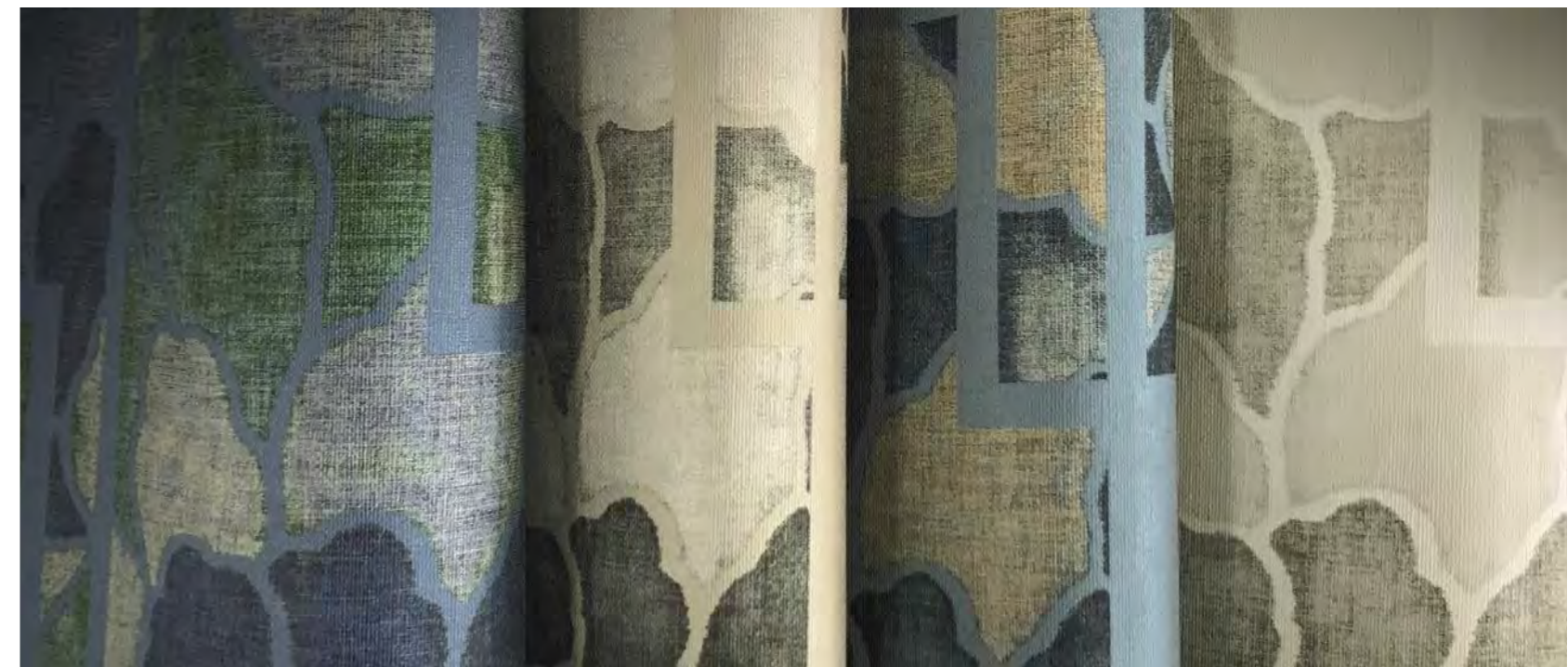

CAPRI Details

STROMBOLI

GRAPHIC ELEMENTS 2

The island of Stromboli is entirely occupied by the volcano with the same name, one of the few still active in the Mediterranean Sea. The frequent eruptions offer an extraordinary spectacle, with streams of fire meeting the deep blue of the ocean after leaving incandescent brushstrokes on the rocky slopes: this exceptional natural phenomenon is recalled by the design of the wallcovering, where tones of red and emerald green create unexpected contrasts. Available also in tone-on-tone combinations. MADE IN ITALY.

DIMENSIONS
68 cm - Inch 26.77
Vertical Repeat 68,5 cm - Inch 27

MATERIALS
Metallized
Non-woven base



*CODE: GA6 9640

COLORS

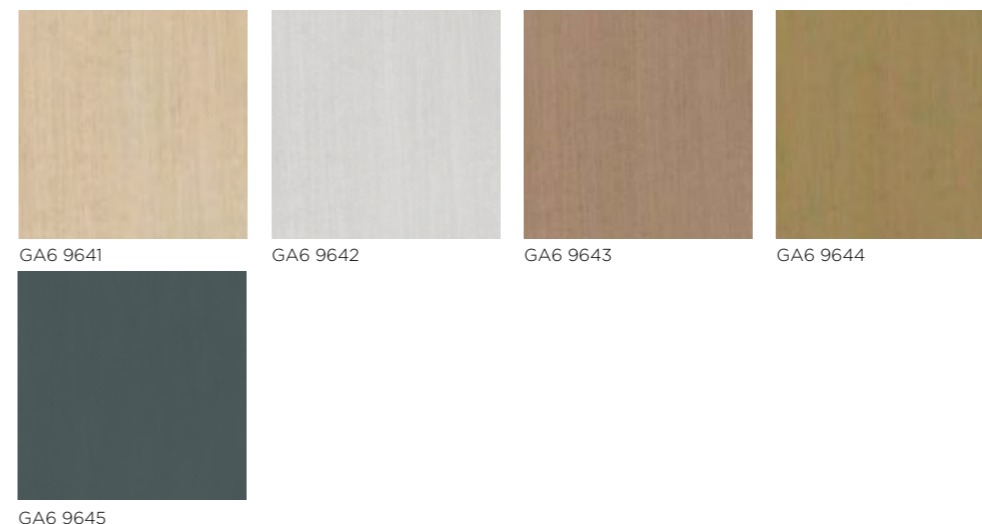

Plain

METALLIZED - STROMBOLI

Five colours coordinated with Stromboli on metallic support. MADE IN ITALY.

DIMENSIONS
68 cm - Inch 26.77
Vertical Repeat 0 cm - Inch 0

MATERIALS
Metallized
Non-woven base



STROMBOLI Details

FABRICS



RODEO Footrests/RUSSEL Bedside table/PAMELA Table lamp

UPHOLSTERY FOR CURVED PRODUCTS

For technical or aesthetic reasons, the following ranges cannot be upholstered with some Armani/Casa fabrics. Please ask our Customer Service for further information every time you must choose a fabric for those products.

ANDROMEDA
BALOON
CLASSIC
ESSEX
JULIE
MARGOT
ORSON
OSIMO
PASCAL
RONDO
TOKYO

SUSTAINABILITY

Armani/Casa pursues the commitment of the whole Armani Group into sustainability: several fabrics within our collection, in fact, feature recycled/upcycled fibers and eco-friendly dyeing processes.

NOTES / LIMITATIONS ON FABRICS

Please note that different uses from what indicated might be possible, but are subject to a preliminary approval for technical or aesthetic reasons.

GAVI (TD055)
Due to its characteristics, we suggest not using this fabric for products featuring the piping on the edges.

GENT (TB056)
Due to the wide repeat, this fabric is normally used without combining the design close to seams/joints. If desired, the continuity of the design must be specifically requested and will receive a dedicated quotation due to the higher consumption of the fabric itself.

GRUMELLO (TD056)
Due to its characteristics, we suggest not using this fabric for products featuring the piping on the edges.

LAFAYETTE (TS076)
Due to the large design, this fabric is available on the Dalia and Lawrence ranges only.

NANJING (TE025)
Due to its characteristics, this fabric is not suitable for products featuring the piping on the edges.

OULU (TC106)
This bi-elastic fabric can be used on the Baloon, Margot and Rondò ranges only.

ROSTOV (TD086)
Due to its characteristics, this fabric is not suitable for products featuring the piping on the edges.

ABBREVIATIONS FOR COMPOSITION MATERIALS

AC	acetate
AF	other fibers
CA	hemp
CO	cotton
CU	cupro (bemberg)
EL	elastodiene
JU	jute
LI	linen
LU	lurex
MD	modal
ME	metal
PA	polyamid
PAN	polyacryl
PC	acrylic
PE	polyethylene
PI	paper
PL	polyester
PM	metal polyester
PVC	polyvinyl chloride
PU	polyurethane
SE	silk
VI	viscose (novafil, rayon, spun-rayon)
WA	angora wool
WM	mohair
WO	wool
WP	alpaka
WS	cachemire

For velvets only: the pile's composition in the catalogue is withinbrackets [].

INTERNATIONAL CARE SYMBOLS

	no washing
	hand wash below 30°C only
	wash below 30°C
	wash below 50°C
	no ironing
	moderate ironing
	medium ironing
	do not steam
	steam iron
	steam iron on the reverse only
	moderate ironing on the reverse only
	medium ironing on the reverse only
	wipe with a damp cloth
	no dry cleaning
	fine dry cleaning only
	medium dry cleaning
	bleach if needed
	do not use chlorine bleach
	dry normal, low heat
	do not tumble dry
	fabric to be cut by the repeat only
	soil repellent treatment
	half dropped: to join two cutlengths you need to shift a half repeat
	we cannot guarantee the exact reproduction of the colour
	irregularities and knots on the ground of the fabrics may occur
	possible shrinking due to the nature of the fabric
	flame retardant fabric
	the position of the selvages is pointed out by the two arrows
	use of lead is suggested
	double stitching absolutely necessary
	reversible fabric
	fabric folded along the half width
	Sustainability Project

No upholstery fabric can be treated with chlorine.



ROSTOV Detail



SURABAYA Detail

PARMA

CAT. A - TA038
 Parma is a technical microfiber with a superficial coating resistant to streaks and other signs that could be caused by accident or improper use.

DIMENSIONS
 Width: 140 cm - Inch 55.1
 Repeat: -

CARE

COMPOSITION
 80%PVC 20%PU

USE
 Heavy



TX154
PEARL

TX155
PLATINUM

TX156
ALUMINIUM

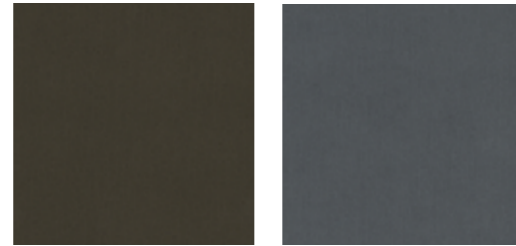

TX157
ANTHRACITE

TX158
POWDER BLUE



PARMA Detail

RAVENSBURG

CAT. A - TA040
 A tight weaving of bicolored yarns is at the origin of the false plain look. The bicolored fantasy weft creates a particular salt and pepper effect and emphasizes the three-dimensional texture of the fabric. Ravensburg is highly resistant and can be machine washed. This fabric is an exclusive developed for the Armani/Casa stores only.

DIMENSIONS
 Width: 144 cm - Inch 56.7
 Repeat: -

CARE

COMPOSITION
 60%PAN 40%PU

USE
 Heavy

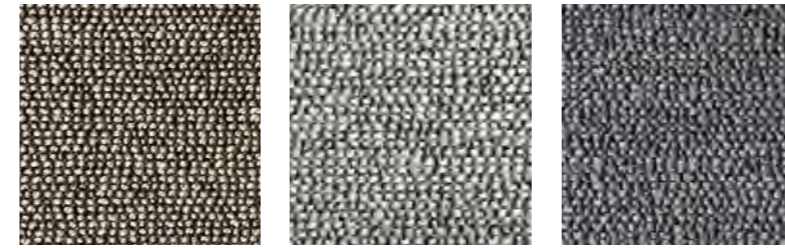

ER027
IVORY/BRONZE

ER028
IVORY/SILVER

ER029
GREY/PETROLEUM

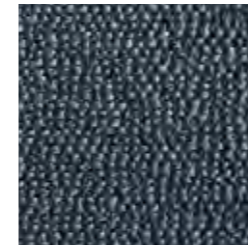

ER030
PETROLEUM/NIGHT BLUE

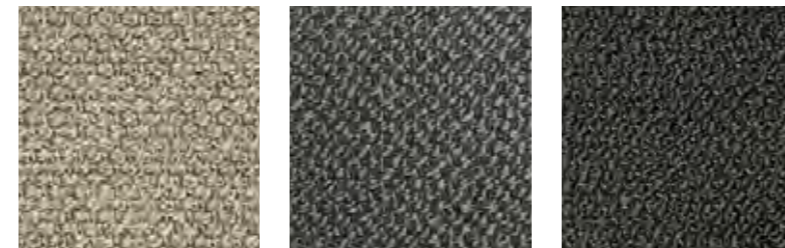

ER024
NATURAL

ER025
TAUPE

ER026
ANTHRACITE

RIGA

CAT. A - TA039
 Riga is a fabric with a rustic textured look, inspired by textiles from Northern Europe. The bulky yarns feature a high thread count to make this fabric more resistant (35'000 Martindale) and confer weight. Riga is developed in a color palette recalling earthy tones. This fabric is an exclusive developed for the Armani/Casa stores only.

DIMENSIONS
 Width: 140 cm - Inch 55.1
 Repeat: -

CARE

COMPOSITION
 88%PAN 12%PL

USE
 Heavy

ROUEN

CAT. A - TA041

The use of chenille recreates the geometric design of a micro checkered motif, adding three-dimensionality to this fabric. The color palette ranges from neutral shades to almost metallic tones of silver, azure, and viridian. The name celebrates the French city of Rouen, famous for its gothic churches and the paved streets of the historical city center. This fabric is an exclusive developed for the Armani/Casa stores only.

DIMENSIONS

Width: 138 cm - Inch 54.3
Repeat: -

CARE

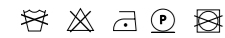

COMPOSITION

70%VI 22%CO 6%LI 2%PA

USE

Heavy



ER031
PEARL



ER032
NATURAL

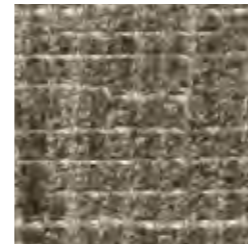

ER033
SAND



ER034
AZURE



ER035
VIRIDIAN



ER036
SILVER





SIRACUSA Detail

SIRACUSA

CAT. A - TAO43

Siracusa shows a rich materic effect thanks to the combination of different yarns (viscose, cotton, polyester, linen) playing around the same colour palette. Siracusa was conceived as a high-performance fabric, with a value of 25'000 Martindale and several other certifications.

DIMENSIONS

Width: 140 cm - Inch 55.1
Repeat: -

CARE

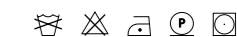

COMPOSITION

35%VI 28%CO 20%PL 17%LI

USE

Heavy



ER048
PLATINUM



ER049
SAGE



ER050
DOVE GREY



ER051
STEEL BLUE



ER052
IVORY



ER053
DOVE GREY



ER054
ANTHRACITE

SALISBURGO

CAT. A - TAO44

A marvelous weaving of chenille confers a soft touch to this high-performance fabric (30'000 Martindale). The warp is obtained from regenerated cotton fibers for a more sustainable impact. The matelassé appearance of Salisburgo reinterprets the iconic *canneté* motif typical of the Armani style. Unless differently indicated, Salisburgo will be applied horizontally on upholstered items.

DIMENSIONS

Width: 140 cm - Inch 55.1
Repeat: -

CARE

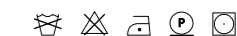

COMPOSITION

56%CO 27%PC 17%PL

USE

Heavy

DENVER

CAT. B - TB048

Denver is marked by a texture vaguely recalling the lizard skin, thanks to its micro scale pattern.

DIMENSIONS

Width: 140 cm - Inch 55.1
Repeat: 5 cm - Inch 2

CARE

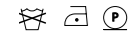

COMPOSITION

87%CO 13%PL

USE

Regular



TR270
IVORY

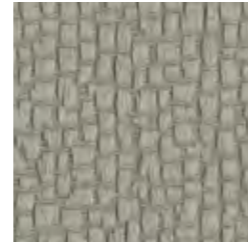

TR271
DOVE GREY



TR272
LIGHT GREY

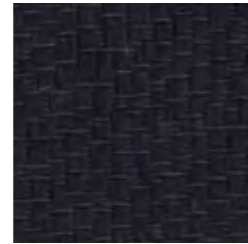

TR273
ANTHRACITE GREY

GABY

CAT. B - TB058

Fabric with irregular ottoman effect. Gaby is reversible: standard use shows the matt side, while the back is shiny and must be specifically requested.

DIMENSIONS

Width: 150 cm - Inch 59
Repeat: -

CARE



COMPOSITION

54%CO 36%PL 10%PC

USE

Heavy

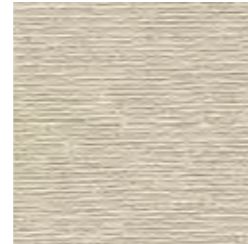

TR659
PEARL REVERSIBLE



TR660
PALE GOLD REVERSIBLE

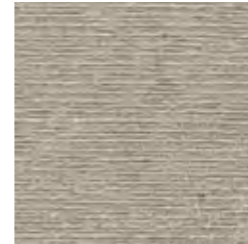

TR661
ICE REVERSIBLE

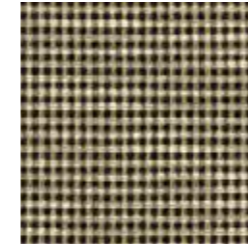

TX140
BLACK/WHITE/BROWN

GENT

CAT. B - TB056

Fabric with a horizontal leaves pattern, presented in tone-on-tone colors. Upon request, this fabric can be applied by turning the design of 90 degrees.

DIMENSIONS

Width: 140 cm - Inch 55.1
Repeat: 205 cm - Inch 81

CARE



COMPOSITION

55%VI 23%CO 22%PA

USE

Heavy

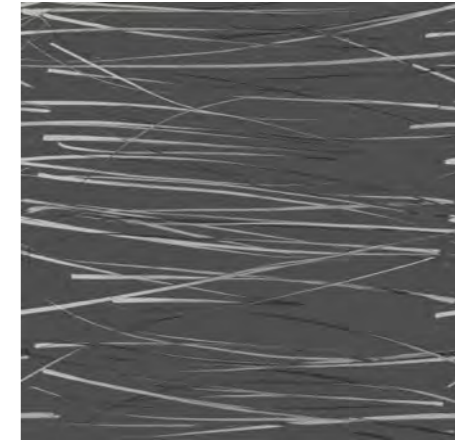

FULL WIDTH

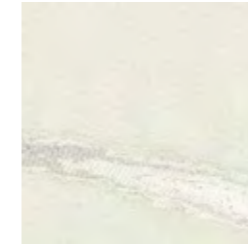

TR618
WHITE

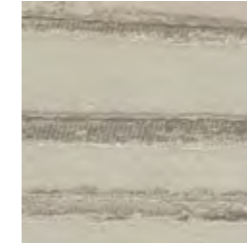

TR619
PEARL

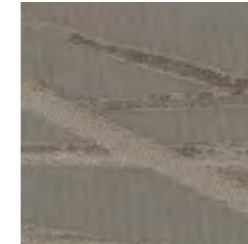

TR620
GREY

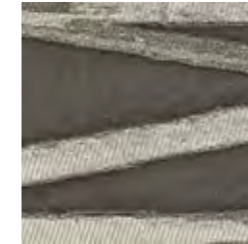

TR621
MILITARY

PERUGIA

CAT. B - TB061

This fabric owes its name to the city of Perugia, in central Italy, famous for its beautiful palaces and monuments dating back to the Renaissance. The *damier* texture of this fabric recalls the ashlar Details of those historical buildings, playing with only three colors to create an elegant light and shade effect.

DIMENSIONS

Width: 140 cm - Inch 55.1
Repeat: -

CARE



COMPOSITION

71%PL 20%CO 5%VI 4%LI

USE

Regular

PISA

CAT. B - TB060

High-performance fabric (30'000 Martindale) reinterpreting vertically the classic *canneté* motif, typical of the Armani style. The design is inspired by intertwined patterns. The look immediately reminds of Giorgio Armani knitwear, as well as sculptural Details like the one that can be admired on marble monuments in the city of Pisa.

DIMENSIONS

Width: 145 cm - Inch 57
Repeat: -

CARE

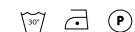

COMPOSITION

57%PL 43%PC

USE

Heavy



TX136
IVORY



TX137
PETROLEUM



TX138
FOREST GREEN



TX139
NIGHT BLUE

REIMS

CAT. B - TB062

Alternating fine and bulky yarns typical of chenille give this fabric a very rich texture. The design of deconstructed geometric elements emerges on the lighter-toned ground enhancing the three-dimensional effect. The fabric is named after the city of Reims, where the crowning of French king used to take place. This fabric is an exclusive developed for the Armani/Casa stores only.

DIMENSIONS

Width: 140 cm - Inch 55.1
Repeat: -

CARE

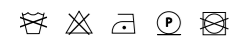

COMPOSITION

56%VI 37%CO 4%PA 3%PC

USE

Regular

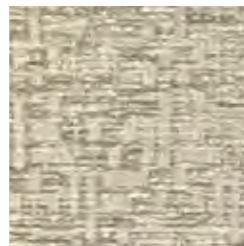

ER021
PEARL



ER022
SILVER



ER023
CEDAR

SIENA

CAT. B - TB063

A plain fabric featuring a micro texture in relief, named after the beautiful Tuscan city of Siena and tributing the colors of the countryside surrounding it. Siena is a highly sustainable fabric made through the use of recycled fibers of nylon for the warp and recycled cotton for the weft.

DIMENSIONS

Width: 140 cm - Inch 55.1
Repeat: -

CARE



COMPOSITION

43%PA 41%CO 16%PL

USE

Heavy



ER055
WHITE

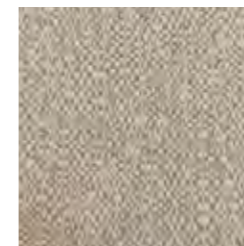

ER056
SAND

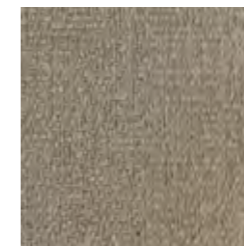

ER057
DOVE GREY

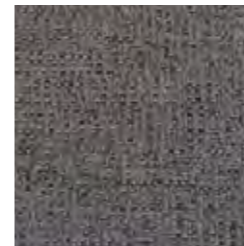

ER058
STEEL BLUE



COLVILLE

CAT. C - TC052

This best-selling fabric reinterprets the iconic Armani motif, the *canneté*, playing with color unevenness of the yarns. The variations of color add movement and a touch of modernity to this classic texture. The silken warp is particularly rich and coupled with thicker cotton wefts.

DIMENSIONS

Width: 140 cm - Inch 55.1
Repeat: 5 cm - Inch 2

CARE



COMPOSITION

84%CO 11% SE 5%VI

USE

Light & decoration

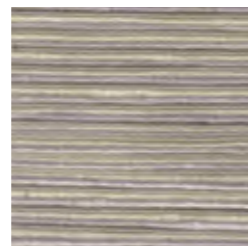

TR181
SAND

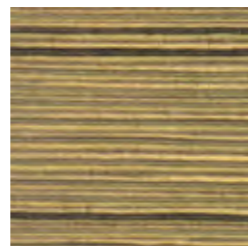

TR182
GOLD

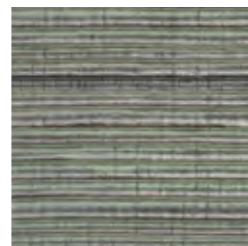

TR183
SAGE GREEN

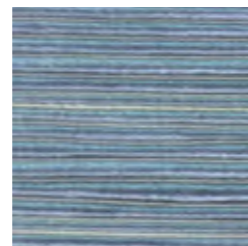

TR184
LIGHT BLUE



TR185
BLUE



TR428
PLATINUM



TR526
ICE



TR527
SILVER

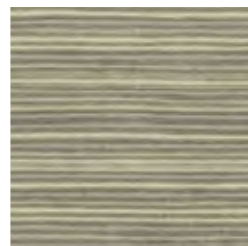

TR530
PEARL

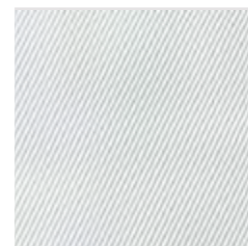

TR188
ICE WHITE



TR189
DOVE GREY

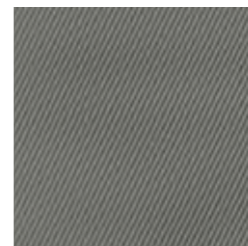

TR190
LIGHT GREY

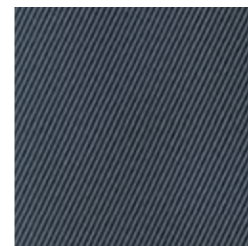

TR193
LIGHT BLUE

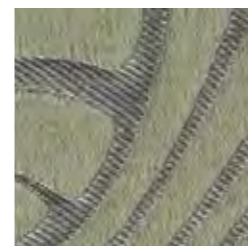

TR226
BEIGE



TR228
COPPER/GREY

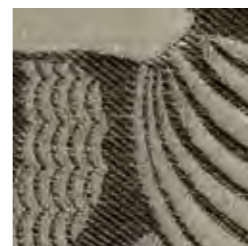

TR229
COPPER/DOVE GREY



HALF WIDTH

CANBERRA

CAT. C - TC053

Canberra is a silk gabardine, a fine type of fabric typical of clothes that highlights the link with the world of fashion.

DIMENSIONS

Width: 140 cm - Inch 55.1
Repeat: -

CARE

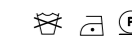

COMPOSITION

77%CO 23%SE

USE

Light & decoration

DECATUR

CAT. C - TC054

This fabric presents an Art Déco inspired design, where stylized leaves are created by long sinuous elements: the smaller units in which the repeating leaf-shaped modules are deconstructed can also give the illusion of tiny fans or shells. To enhance the three-dimensional effect, those modules are matt and embossed on a shiny silk ground.

DIMENSIONS

Width: 140 cm - Inch 55.1
Repeat: 35 cm - Inch 14

CARE



COMPOSITION

63%LI 21%AC 16%PL

USE

Regular

DORCHESTER

CAT. C - TC060
Dorchester is a special blend of chenille viscose on a cotton base that perfectly imitates the look and the hand of velvet.

DIMENSIONS
Width: 130 cm - Inch 51
Repeat: -

CARE

COMPOSITION
59%CO 41%VI

USE
Heavy



TR319
IVORY

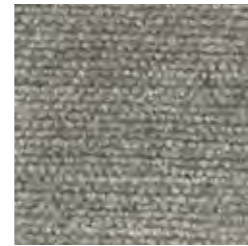

TR320
LIGHT GREY

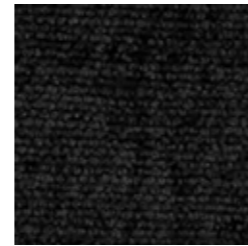

TR323
ANTHRACITE GREY

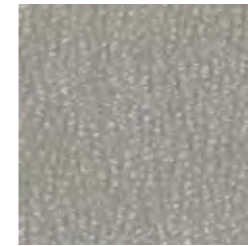

TR498
SAND

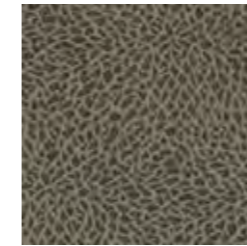

TR499
TAUPE

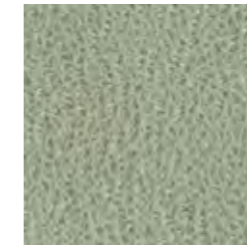

TR500
SAGE

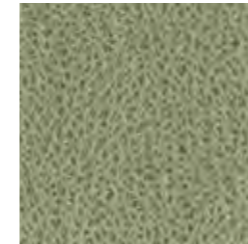

TR501
GOLD GREEN

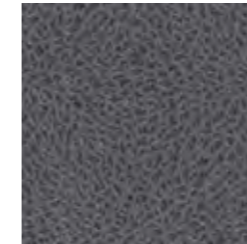

TR502
GREY



TR503
ANTHRACITE

ENGLAND

CAT. C - TC074
The botanic inspiration is visible in the micro texture of this fabric, vaguely resembling a cell structure of a leaf.

DIMENSIONS
Width: 140 cm - Inch 55.1
Repeat: 11 cm - Inch 4

CARE

COMPOSITION
33%CO 67%PL

USE
Heavy

EDMONTON

CAT. C - TC065
Fabric inspired by the shade of royal oak trees, reproduced with a fresco effect. The design is the same featured on the Versailles wallcovering.

DIMENSIONS
Width: 140 cm - Inch 55.1
Repeat: 182 cm - Inch 72

CARE

COMPOSITION
84%AC 16%SE

USE
Light & decoration



FULL WIDTH

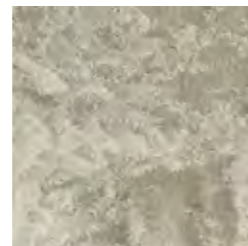

TR429
IVORY



TR430
GOLD

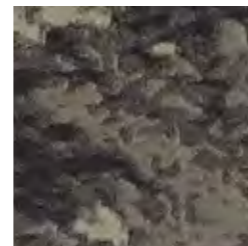

TR431
GREY GOLD

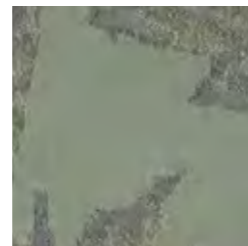

TR432
SAGE

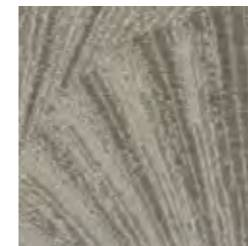

TR708
IVORY

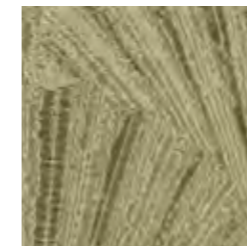

TR709
GOLD

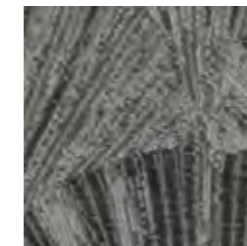

TR710
GREY

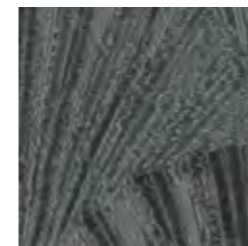

TR711
PEACOCK

HAVANA

CAT. C - TC090
Havana presents a geometric pattern of repeated sea shells, with a clear Art Déco inspiration reminding the typical fan-shaped designs of ceramic tiles from the Thirties. The design is the same featured on the Oberon wallcovering.

DIMENSIONS
Width: 140 cm - Inch 55.1
Repeat: 15 cm - Inch 6

CARE

COMPOSITION
68%AC 32%CO

USE
Light & decoration

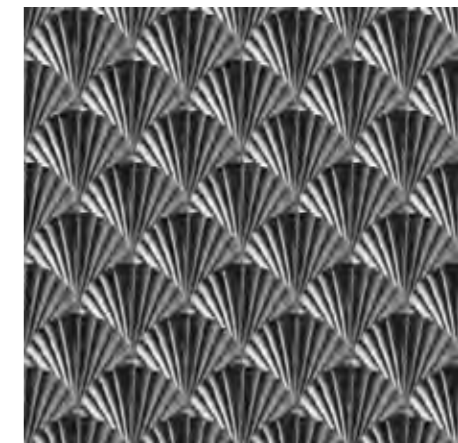

HALF WIDTH

LYON

CAT. C - TC096

This fabric is inspired by an embroidered evening dress kept in the Armani/Silos archive, where thousands of sequins give rhythm to the surface. To imitate the defining three-dimensionality of the original dress, this fabric plays with the different tensions created by the rigid wefts - matt cotton and shiny acetate - combined with the typical elasticity of the silk warp.

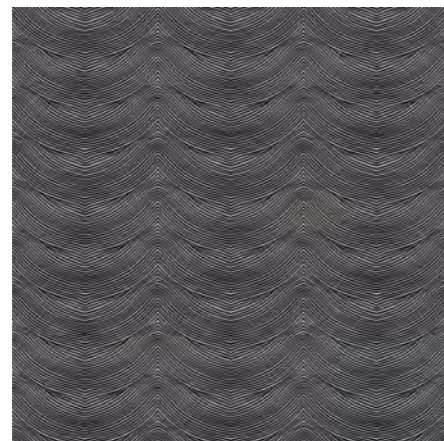

HALF WIDTH

DIMENSIONS

Width: 140 cm - Inch 55.1
Repeat: 22 cm - Inch 9

CARE

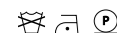

COMPOSITION

52%CO 28%AC 20%SE

USE

Light & decoration



TR825
IVORY

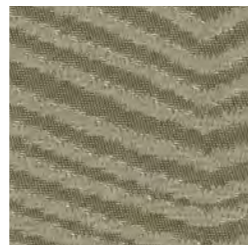

TR827
SILVER/GOLD

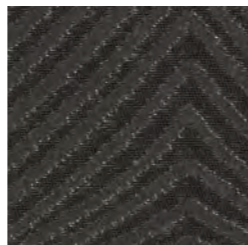

TR829
BLUE SHADOW

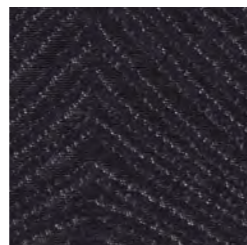

TR831
BLUE NIGHT



TX052
IVORY/GOLD

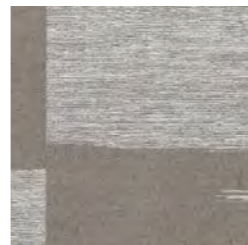

TX053
IVORY/SILVER



TX054
GREY/AZURE



TX055
PETROLEUM/GREEN



TX056
VIRIDIAN/RED

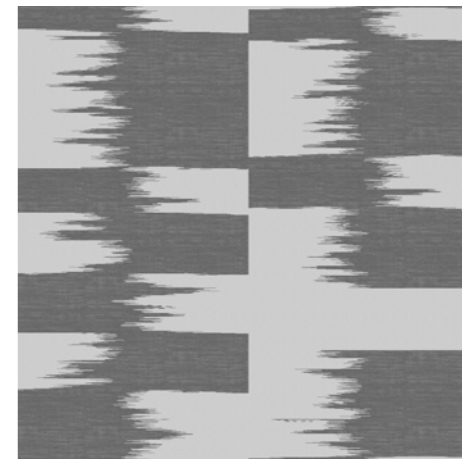

FULL WIDTH

NICE

CAT. C - TC102

This jacquard fabric features a design inspired by the ikat technique. The large-scaled interrupted design is created with extra luminous weft yarns, which alternate with linen yarns on the surface of the fabric.

DIMENSIONS

Width: 140 cm - Inch 55.1
Repeat: 65 cm - Inch 25.5

CARE



COMPOSITION

57%VI 33%CO 10%SE

USE

Light & decoration

LUXEMBOURG

CAT. C - TC094

The irregular geometric relief design is created with chenille weft yarn and micro damier on the background.



TR812
WHITE



TR813
ICE



TR814
IVORY



TR815
DOVE GREY



TR816
SILVER/IVORY



TR817
LIGHT BLUE/IVORY



TR818
BLUE SHADOW

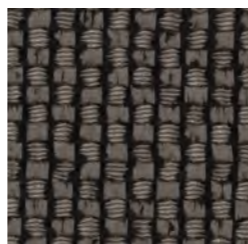

TR819
ANTHRACITE/BLACK



TX043
IVORY



TX045
SILVER



TX046
PETROLEUM

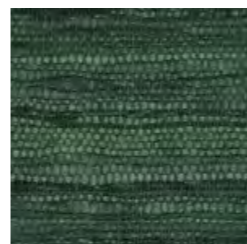

TX048
FOREST GREEN



TX049
BLACK

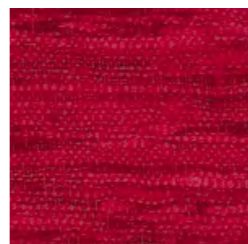

TX050
RED

DIMENSIONS

Width: 135 cm - Inch 53
Repeat: -

CARE



COMPOSITION

33%PA 31%VI 31%CO 5%PL

USE

Heavy

NÎMES

CAT. C - TC101

Precious tussah silk with an unmatched multidirectional sheen, achieved with hand-spun yarns woven by hand. The uneven yarn woven pick by pick gives an undulated rhythm to the lustrous fabric, creating gradient hues on its textured surface. The use of strong, bright hues modernizes the traditional technique.

DIMENSIONS

Width: 135 cm - Inch 53
Repeat: -

CARE



COMPOSITION

100%SE

USE

Light & decoration

OLBIA

CAT. C - TC105

Olbia shows a diamond texture in relief, developed in plain colors. Available in three neutral tones and three more vivid colors.

DIMENSIONS

Width: 130 cm - Inch 51
Repeat: -

CARE

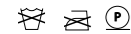

COMPOSITION

32%PA 31%CO 25%AC 12%PC

USE

Heavy

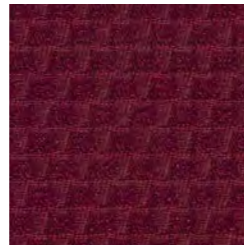

TX100
RED

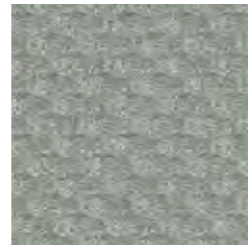

TX102
APPLE GREEN

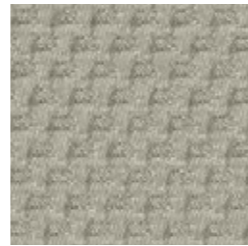

TX103
SAND

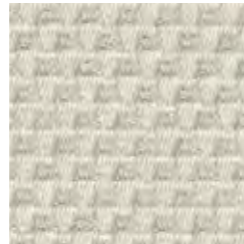

TX104
IVORY



TX116
GHIACCIO

ORLANDO

CAT. C - TC103

Orlando plays on a wide *canneté* texture, obtained thanks to a *matelassé* technique. This range expands the offer given by our best-selling Jackson fabric (TD065), but with matt colors instead of using a metallic finishing.

DIMENSIONS

Width: 135 cm - Inch 53
Repeat: -

CARE

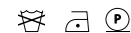

COMPOSITION

45%CO 28%WO 27%LI

USE

Regular

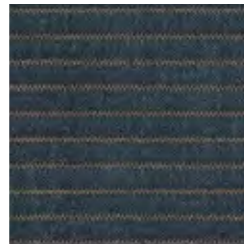

TX089
VIRIDIAN



TX090
AZURE



TX091
ROSE



TX092
GREY



TX093
SAND

OSLO

CAT. C - TC104

Oslo features a texture made with chenille wefts in relief on a shiny ground. The use of this technique creates two particular effects: first, at first glance the surface looks similar to a velvet, but it is actually a thin three-dimensional *canneté*; second, depending on how light hits the surface, the fabric shows a different color hue especially on variants developed with contrasted colors.

DIMENSIONS

Width: 140 cm - Inch 55.1
Repeat: -

CARE



COMPOSITION

65%PA 30%AC 5%PC

USE

Heavy



TX094
VIRIDIAN/ANTHRACITE



TX095
PETROLEUM/BLUE NIGHT



TX096
RED/BLUE NIGHT



TX097
SILVER



TX098
PALE GOLD

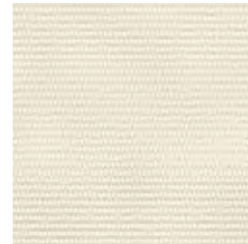

TX099
IVORY

OULU

CAT. C - TC106

Oulu is a bi-elastic fabric, highly resistant thanks to the combination of fibers (viscose, linen and elastane) used in the weaving. Available in three colors, this fabric can be used on the Baloon, Margot and Rondò ranges only. Covers made in this fabric are not removable.

DIMENSIONS

Width: 140 cm - Inch 55.1
Repeat: -

CARE



COMPOSITION

64%VI 31%LI 5%EA

USE

Heavy

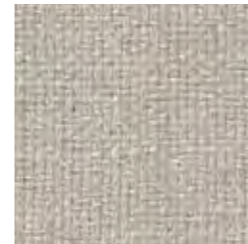

TX105
ICE



TX106
WHITE



TX107
NATURAL

PALERMO

CAT. C - TC108

The yarns of the warp of Palermo are particularly thick, and are weaved with viscose chenille wefts thanks to a special technique (an exclusive for Armani/Casa): the chenille is "caged" by the other yarns - so that its pile becomes invisible - but gives the fabric a smooth and pleasant hand. The high density of linen results also in a very resistant fabric (80'000 Martindale). The *mélange* effect of some colors is given by the dying process carried out on the single yarns, which also feature typical "knots" due to their thickness and the mix of fibers they contain.

DIMENSIONS

Width: 140 cm - Inch 55.1
Repeat: -

CARE



COMPOSITION

46%PC 26%VI 12%PL 10%LI 6%CO

USE

Heavy



TX126
PEARL



TX127
SAND



TX128
SILVER



TX129
PEARL/AZURE

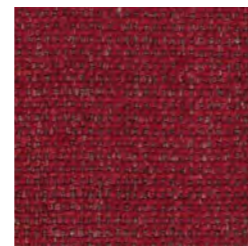

TX130
RED



TX131
PETROLEUM/
VERONESE GREEN

PANAMA

CAT. C - TC109

A plain fabric showing a wavy surface thanks to the use of yarns of different materials. Despite the high percentage of linen and the raw appearance, the fabric is actually very soft due to the finishing phase, which confers a more pleasant touch. This fabric is very resistant (80'000 Martindale).

DIMENSIONS

Width: 135 cm - Inch 53
Repeat: -

CARE

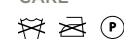

COMPOSITION

45%LI 23%PC 18%CO
7%BA 5%PA 2%PL

USE

Heavy

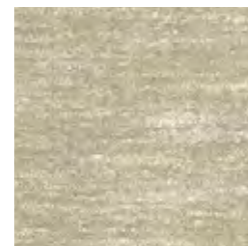

TX132
SAND



TX133
NATURAL

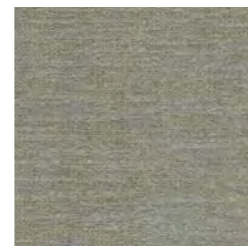

TX134
AZURE



TX135
GREEN

PORTOFINO

CAT. C - TC107

Dedicated to the glamorous village located on the coasts of Northern Italy, Portofino celebrates the Mediterranean atmosphere taking inspiration from the design of intertwined wicker baskets. The alternance of shiny (acetate) and matt (cotton) fibers add depth to the design, recalling the look of sea waves. The color palette is particularly vivid, enhancing the luster of this shiny fabric.



TX117
GREY/IVORY/LIME



TX119
PETROLEUM/SILVER/
LIME

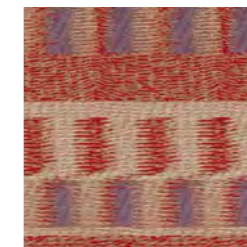

TX120
RED/LILAC/GOLD

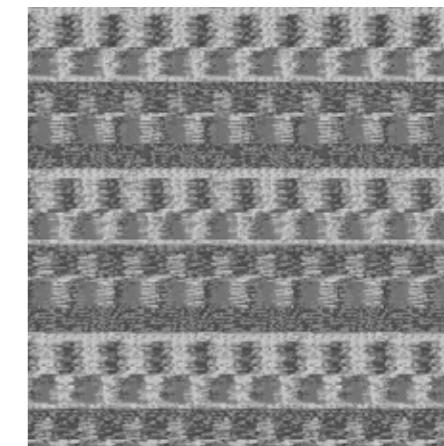

HALF WIDTH

DIMENSIONS

Width: 135 cm - Inch 53
Repeat: 27 cm - Inch 11

CARE



COMPOSITION

41%CO 34%AC 25%PL

USE

Light & decoration





SAO PAULO Detail

SANTIAGO

CAT. C - TC112
Geometries and color blocks inspired Santiago, a cotton and polyester jacquard. This fabric takes inspiration from Piet Mondrian's paintings, with three variants developed in a rich colour palette comprising vibrant tones combined with more neutral hues.



ER059
VIRIDIAN/STEEL BLUE/
AZURE



ER060
STEEL BLUE/SILVER/
GREY



ER061
VIRIDIAN/STEEL BLUE/
RED



FULL WIDTH

DIMENSIONS
Width: 150 cm - Inch 59
Repeat: 105,5 cm - 41.5

CARE
☒ ☒ ☒ ☒ ☒

COMPOSITION
52%CO 48%PL

USE
Light & decoration

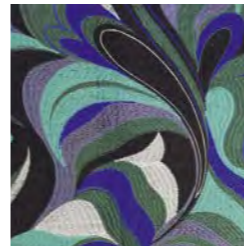

ER063
VIRIDIAN/STEEL BLUE/
INDIGO

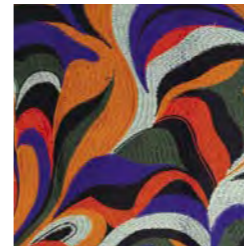

ER064
COPPER/RED/VIRIDIAN

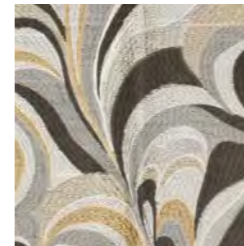

ER065
PALE GOLD/PLATINUM/
GREY



FULL WIDTH

SAO PAULO

CAT. C - TC113
A bold all-over embroidered fabric featuring a Surrealist design. The inspiration for the pattern comes from tropical elements (palm leaves, flowers, parrot feathers) and Carnival folklore interpreted with an abstract approach. The striking combinations show vivid touches of colour. Sao Paulo presents polyester embroideries on a cotton/viscose ground; the embroidered area covers a width of 126 cm. The fabric is suitable for regular use (50'000 Martindale). Slight irregularities are a defining feature of the product.

DIMENSIONS
Width: 140 cm - Inch 55.1
Repeat: 39 cm - Inch 15.3

CARE
☒ ☒ ☒ ☒ ☒

COMPOSITION
47%CO 35%VI 18%SPUN POLY

USE
Regular

SIVIGLIA

CAT. C - TC111

The geometric design of Siviglia takes inspiration from a reinterpreted aerial view of the palace and the gardens of the Alcázar, located in the eponymous city. The maze-looking design on this three-dimensional jacquard is obtained thanks to the use of sustainable fibers: in particular, the warp comes from regenerated nylon, while the wefts come from the upcycling of selvages leftovers.

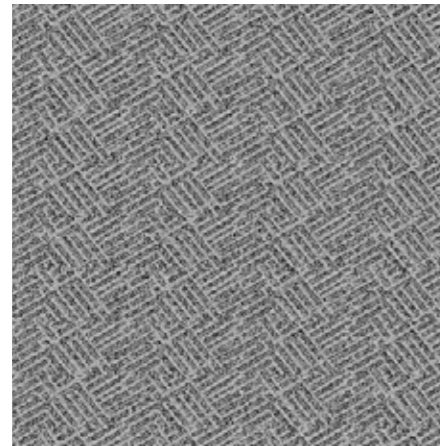

FULL WIDTH

DIMENSIONS

Width: 135 cm - Inch 53.1
Repeat: 17 cm - Inch 6.7

CARE

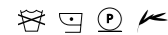

COMPOSITION

33%CO 25%PA 14%VI 12%AC
10%PL 6%AF

USE

Heavy



TX183
PLATINUM



TX184
IVORY

STOCKHOLM

CAT. C - TC110

Stockholm presents a classic Armani design: a shiny/matt checkered motif weaved with a matelassé technique. This three-dimensional jacquard is obtained thanks to the use of sustainable fibers: in particular, the warp comes from regenerated nylon, while the wefts come from the upcycling of selvages leftovers.

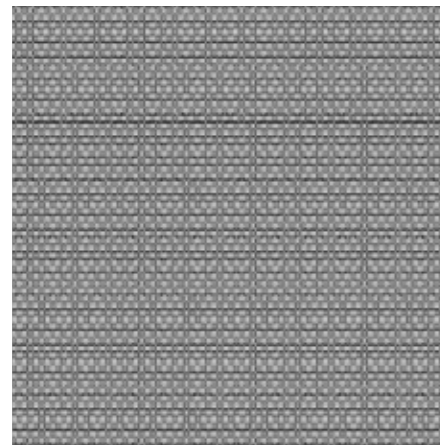

FULL WIDTH

DIMENSIONS

Width: 135 cm - Inch 53.1
Repeat: 4 cm - Inch 1.57

CARE



COMPOSITION

34%CO 23%PA 15%VI 12%AC
10%PL 6%AF

USE

Heavy



TX179
IVORY



TX180
PLATINUM



TX182
STEEL BLUE



STOCKHOLM Detail

FARNESE

CAT. D - TD049
Farnese presents a fris  texture, with a highly sophisticated glossy and matt effect.



TR584
PEARL

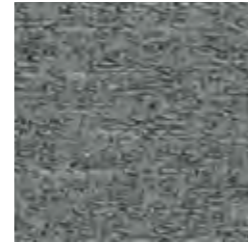

TR587
PLATINUM

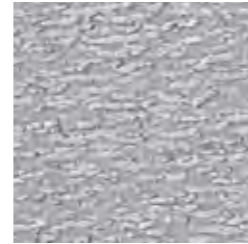

TR609
ICE

DIMENSIONS
Width: 140 cm - Inch 55.1
Repeat: -

CARE

COMPOSITION
55%VI 35%CO 10%PA

USE
Heavy

GRUMELLO

CAT. D - TD056
Cotton velvet printed with shagreen pattern. The print creates a layer giving the illusion of a three-dimensional look similar to leather.

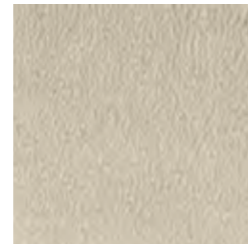

TR675
PEARL



TR677
GREY

DIMENSIONS
Width: 140 cm - Inch 55.1
Repeat: -

CARE

COMPOSITION
[100%CO] 95%CO 5%PL

USE
Heavy

JACKSON

CAT. D - TD065
Jackson is a *cannet * reinterpreted in a modern luxurious way: the stripes are wider than usual thanks to the use of thick wool yarns, and are covered with metal laminate.



TR795
PALE GOLD



TR797
NICKEL

DIMENSIONS
Width: 130 cm - Inch 51
Repeat: -

CARE

COMPOSITION
53%CO 47%WO

USE
Regular

JAIPUR

CAT. D - TD064
Irregular silk *cannet * with a shiny finish.

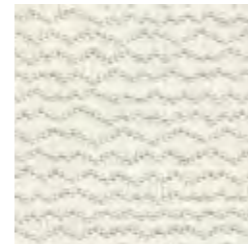

TR784
WHITE

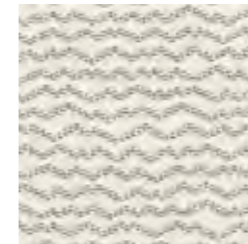

TR785
SAND

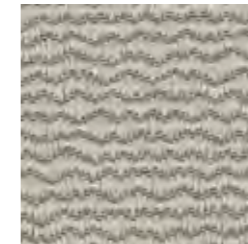

TR786
PLATINUM



TR787
ICE



TR788
PALE GOLD



TR789
TERRACOTTA



TR791
JADE GREEN

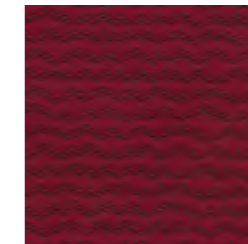

TR792
RUBY RED

DIMENSIONS
Width: 140 cm - Inch 55.1
Repeat: -

CARE

COMPOSITION
85%CO 15%SE

USE
Light & decoration

JUSO

CAT. D - TD061
The geometric micro and macro pattern of Juso takes inspiration from the *tsubas*, the rich hand guards of the Japanese swords (*katanas*). The same design is featured on the Towada wallcovering.

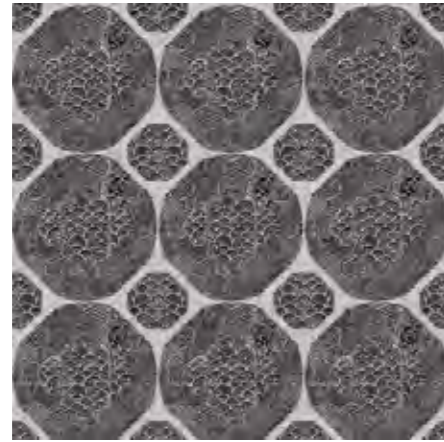

HALF WIDTH

DIMENSIONS
Width: 135 cm - Inch 53
Repeat: 24 cm - Inch 9

CARE
🧺 🧼 🚫

COMPOSITION
43%AC 30%CO 27%SE

USE
Light & decoration



TR747
IVORY



TR749
PALE GOLD



TR750
SILVER/BRONZE



TR832
WHITE



TR833
GOLD



TR834
SABBIA



TR837
NICKEL

LANGSA

CAT. D - TD067
Langsa presents a micro geometric pattern taken from a Detail of Japanese *tsubas* (guards of *katana* swords).

DIMENSIONS
Width: 140 cm - Inch 55.1
Repeat: -

CARE
🧺 🧼 🚫

COMPOSITION
68%LI 18%SE 14%CO

USE
Light & decoration

NOLA

CAT. D - TD077
All over embroideries create a gradient colored pattern which recalls a cloudy landscape with hills and treetops. The neutral colored yarns create a vertical zig-zag texture on the fabric surface.

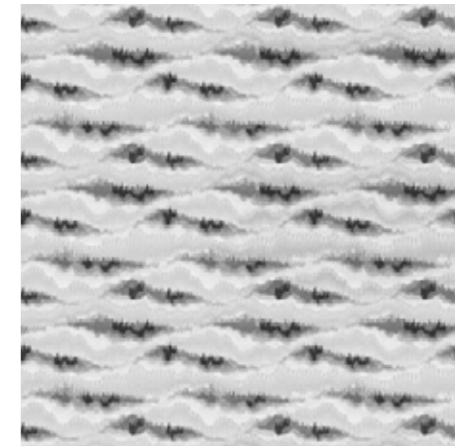

HALF WIDTH

DIMENSIONS
Width: 130 cm - Inch 51
Repeat: 38 cm - Inch 15

CARE
🧺 🧼 🚫

COMPOSITION
60%CO 40%VI

USE
Light & decoration



TX005
GOLD/NICKEL



TX006
NICKEL/AZURE



JUSO Detail

NORFOLK

CAT. D - TD078
This classic *canneté* weave is interrupted with a diagonal linear design. The silk fabric is available in bright hues and classic neutrals.



TX007
IVORY



TX008
PLATINUM



TX009
PALE GOLD

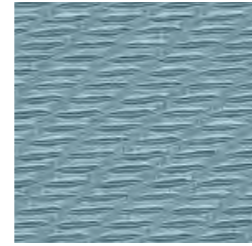

TX010
AZURE

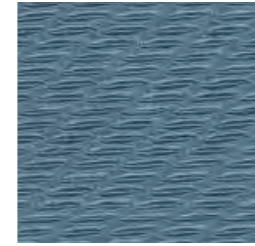

TX011
PETROLEUM

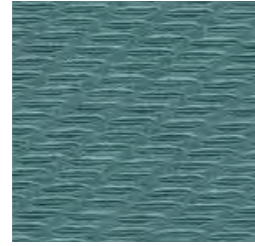

TX012
VIRIDIAN



TX013
FOREST GREEN

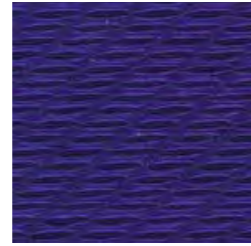

TX014
INDIGO



TX015
BLACK

DIMENSIONS
Width: 140 cm - Inch 55.1
Repeat: -

CARE

COMPOSITION
83%CO 17%SE

USE
Light & decoration

NOTO

CAT. D - TD079
A laminated fabric finished with a *moiré* treatment. *Moiré* is a finishing technique that modifies the surface structure of the fabric by pressing it with metal cylinders, whose purpose is to change the reflection of light on the fibers. The fabric takes on the characteristic look that can be compared to the veins of wood or a watered appearance. This irregular design is developed on "campo unico", which means that the pattern is sized on the whole width of the fabric.

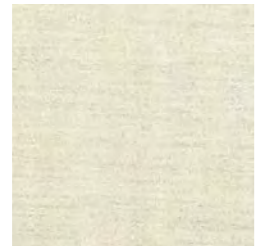

TX037
PEARL



TX038
PALE GOLD

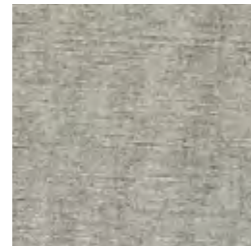

TX039
SILVER

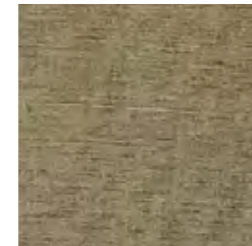

TX041
BRONZE

DIMENSIONS
145 cm - Inch 57
Repeat: -

CARE

COMPOSITION
45%CO 39%VI 16%LI

USE
Light & decoration

OKINAWA

CAT. D - TD082
A jacquard fabric featuring a dreamy Japanese landscape, with trees and hills shading into clouds to create a sort of "infinite" effect. All color variants - from bolder to more neutral ones - are particularly rich in hues, depicting the pattern with almost a watercolor appearance. Some Details clearly show a twill weaving in micro scale.

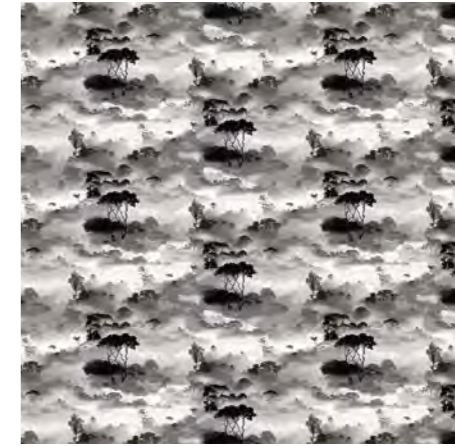

HALF WIDTH

DIMENSIONS
Width: 140 cm - Inch 55.1
Repeat: 43 cm - Inch 22

CARE

COMPOSITION
37%AC 34%CO 29%SE

USE
Light & decoration

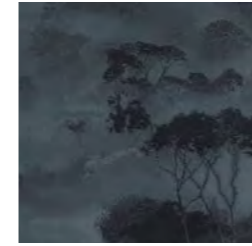

TX075
VIRIDIAN/BLUE NIGHT



TX076
VIRIDIAN/INDIGO

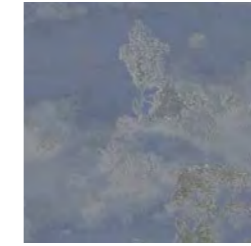

TX077
PETROLEUM/PEARL



TX078
GOLD/APPLE GREEN



TX079
ROSE/GOLD

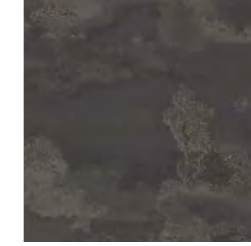

TX080
ANTHRACITE/BRONZE



TX081
ICE



TX082
PALE GOLD



TX083
IVORY

PECHINO

CAT. D - TD084

Pechino (Italian for Beijing) is a tribute to the capital of China, merging the creativity of Art Déco with Oriental elements. A solid background is enriched by the addition of squared/rectangular shapes in contrast, coupled with the stylized silhouettes of Chinese umbrellas seen from the above. This joyful fabric plays with colors and geometry, both in terms of aesthetics and technique: the union of silk warp and cotton wefts creates a sophisticated alternance of reflections, made precious by the use of a dotted yarn to design the umbrellas.

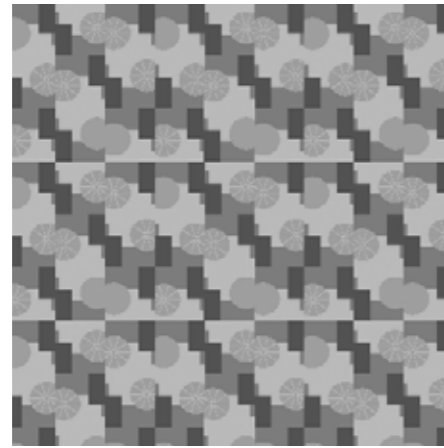

HALF WIDTH

DIMENSIONS

Width: 145 cm - Inch 57
Repeat: 57 cm - Inch 22

CARE

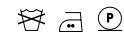

COMPOSITION

50%CO 40%SE 10%VI

USE

Regular



TX151
PALE ROSE/AZURE/GOLD



TX152
ROSE/AZURE/IVORY



TX153
RED/BLUE/IVORY



TX159
ICE



TX160
IVORY

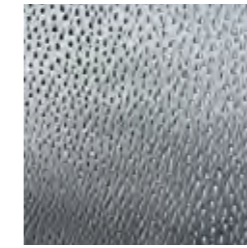

TX161
SILVER/AZURE

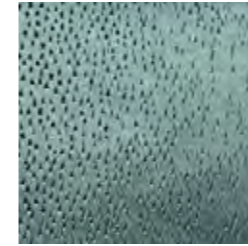

TX162
CEDAR/PETROLEUM

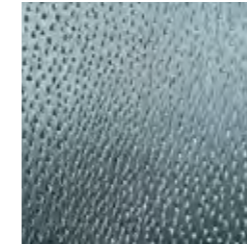

TX163
AZURE/IVORY

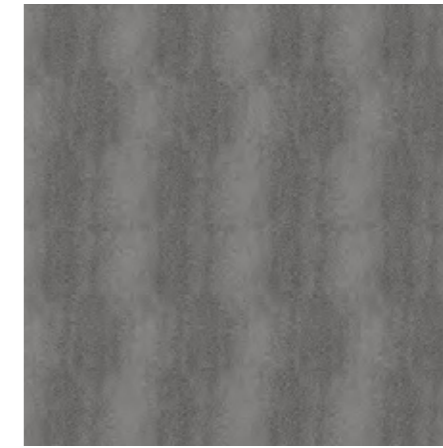

HALF WIDTH

RIVOLI

CAT. D - TD085

The iconic shagreen texture, a classic of the Giorgio Armani aesthetics, is reproduced on this fabric thanks to the careful combination of different yarns: cotton dots are weaved in relief on a silk/acetate ground, imitating the typical scales of this refined rawhide. The surface is enriched by luminous reflections to give the fabric an even more luxurious look.

DIMENSIONS

Width: 140 cm - Inch 55.1
Repeat: 43 cm - Inch 22

CARE

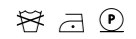

COMPOSITION

26%SE 44%CO 30%AC

USE

Light & decoration



RIVOLI Detail

ROSTOV

CAT. D - TD086

This precious jacquard stands out for its design inspired by agate slabs in macro-scale. The typical geometry of this stone is emphasized by the use of visually strong combinations of colors, ranging from watery tones to earthly hues, from forest green to melon orange. The name recalls antique Russian cities and their imperial palaces, whose rooms often had decorative Details - or even entire walls - clad in hardstones. This fabric is an exclusive developed for the Armani/Casa stores only.



HALF WIDTH

DIMENSIONS

Width: 148 cm - Inch 58.26
Repeat: -

CARE



COMPOSITION

49%PL 38%CO 13%SE

USE

Light & decoration



ER018
GREEN/BRONZE

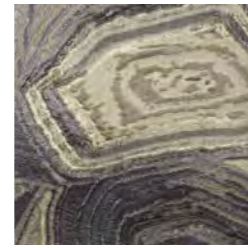

ER019
SILVER/GOLD

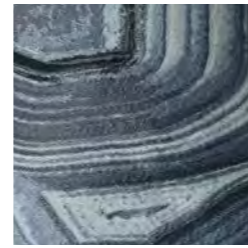

ER020
AZURE/FOREST GREEN



ER040
AZURE/MELON

SAINT MORITZ

CAT. D - TD088

Saint Moritz introduces, for the first time, a bouclé fabric into the Armani Casa collection. The rich weaving - featuring a remarkable thread count and irregularities typical of this kind of fabric - states an immediate link to the world of fashion.

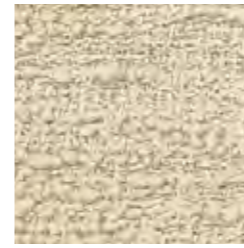

ER045
IVORY



ER046
DOVE GREY



ER047
GREY/BLUE

DIMENSIONS

Width: 140 cm - Inch 55.1
Repeat: -

CARE



COMPOSITION

50%WV 30%LI 12%VI 6%CO 2%PA

USE

Heavy



SAINT MORITZ Detail



SURABAYA Detail

SURABAYA

CAT. D - TD087

Surabaya takes inspiration from the aerial view of an Asian landscape with water canals and rice fields. The spectacular three-dimensional pattern is obtained thanks to the use of a jacquard weaving with embossed Details. The wefts of this fabric are made with regenerated fibers, coupled with a precious silk warp.

DIMENSIONS

Width: 135 cm - Inch 53.1
Repeat: 90 cm - Inch 5.4

CARE



COMPOSITION

63%CO 18%SE 10%PL 6%AF 3%VI

USE

Light & decoration

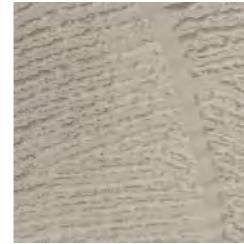

TX170
IVORY



TX171
ICE



TX172
PALE GOLD

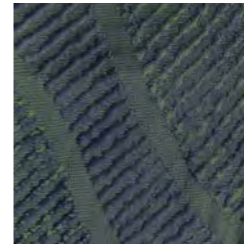

TX173
VIRIDIAN

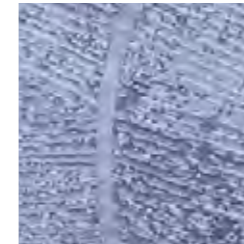

TX174
STEEL BLUE

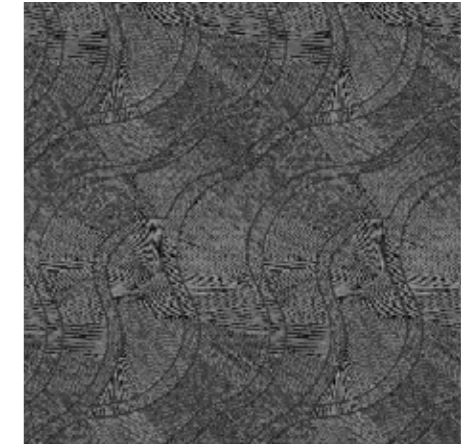

FULL WIDTH

NAGANO

CAT. E - TE024

A Japanese kimono is the source of inspiration of this jacquard fabric's flower décor. A geometric grid design gives a more contemporary look, where the brilliant colors on silk satin and shiny viscose wefts add a splash of light to the fabric.

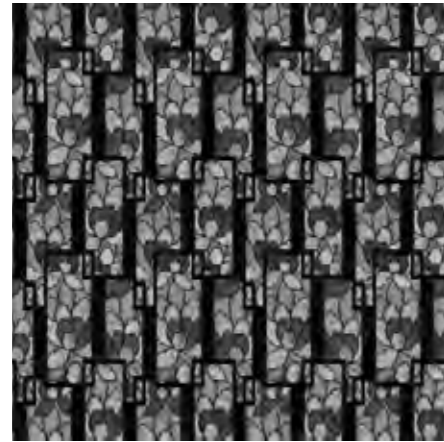

HALF WIDTH

DIMENSIONS

Width: 140 cm - Inch 55.1
Repeat: 65 cm - Inch 25.5

CARE

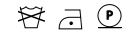

COMPOSITION

44%AC 21%VI 19%SE 16%LI

USE

Light & decoration



TX016
SAND



TX017
ICE/ANTHRACITE

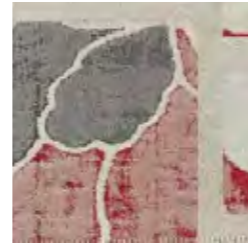

TX018
SAND/RED/BLACK



TX019
VIRIDIAN/GOLD

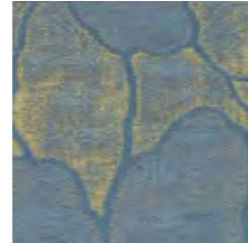

TX020
PETROLEUM/GOLD

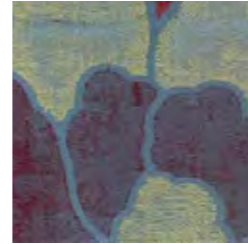

TX023
PETROLEUM/RED/GOLD

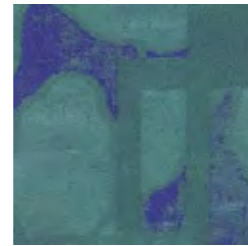

TX024
VIRIDIAN/BLUE/BLACK

NANJING

CAT. E - TE025

Dragonflies and bamboo leaves are drawn on a *canneté* background. The décor of the jacquard silk fabric is created with woven effects that simulate embroideries. The colorful variants and subtle neutral tones are all enlivened by bright touches of color on intricate Details. Since this fabric is not suitable for piping, a range of decorative cushions with the same name can be found in our collection.



HALF WIDTH

DIMENSIONS

Width: 140 cm - Inch 55.1
Repeat: 26 cm - Inch 10

CARE

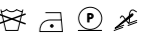

COMPOSITION

56%AC 22%LI 19%SE 3%VI

USE

Light & decoration

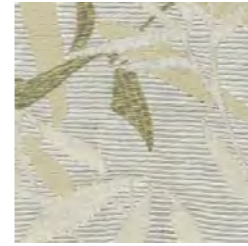

TX026
SAND/PLATINUM/COPPER



TX028
SAND/LIME/PEACH



TX029
ICE/BLACK/GOLD

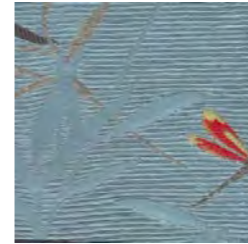

TX031
AZURE/GREY/PEACH

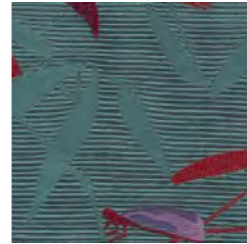

TX032
VIRIDIAN/RED/LILAC

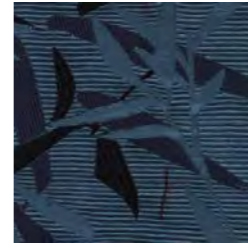

TX033
PETROLEUM/YELLOW



TX148
RED/SILVER



TX149
BLUE/GREEN/ROSE



TX150
GREEN/BLUE

PORTLAND

CAT. E - TE028

Fabric dedicated to the landscapes of Oregon, where Portland is located. The infinite sky, the quiet rivers, the snowy mountains, the deep forests and the waves of the sea offer an exceptional color palette which inspired this fabric, where all the hues merge and blur one into the other: to achieve this result, this fabric is entirely embroidered and recreates a sort of ikat effect.

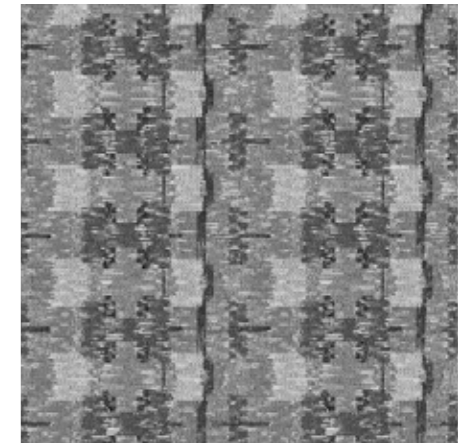

HALF WIDTH

DIMENSIONS

Width: 135 cm - Inch 57
Repeat: 29 cm - Inch 11

CARE



COMPOSITION

65%LI 35%VI

USE

Light & decoration



PORTO Detail

PORTO

CAT. E - TE027

With its name, this fabric echoes the colorful atmospheres of Portugal: the design is inspired by *azulejos*, the ceramic tiles of the Portuguese tradition, featuring enamel-painted decorative motifs. Armani/Casa reinterprets this concept by adding a rigorous geometry, mixing the shimmering mood of *azulejos* to a deconstructed *chevron*. All figures of Porto are embroidered: the final result is a very rich kaleidoscope effect, combining a contemporary inspiration - the enamelled tiles - with a textile icon - the *chevron* - typical of the Armani DNA.



TX145
GOLD/WHITE



TX146
RED/WHITE



TX147
GREEN/WHITE

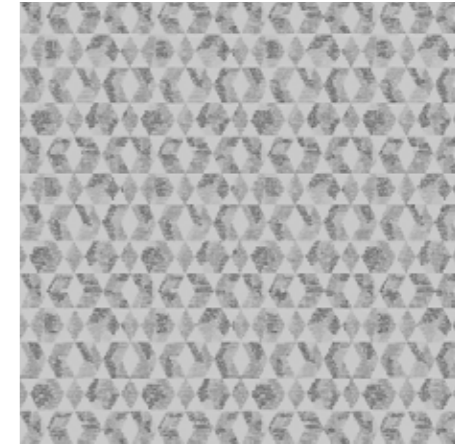

HALF WIDTH

DIMENSIONS

Width: 130 cm - Inch 53
Repeat: 39 cm - Inch 15

CARE

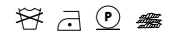

COMPOSITION

63%PL 13%LI 12%CO 12%VI

USE

Light & decoration

RAVENNA

CAT. E - TE029

Ravenna takes inspiration from the layers of mother of pearl inside shells. The typical design of this precious material is recreated through a jacquard technique using shiny yarns – silk, acetate, viscose – alternated to matt linen ones. The large wavy design adds movement to this fabric named after the Italian city of Ravenna, famous for the mosaics of the Byzantine period which often featured mother of pearl tiles.



HALF WIDTH

DIMENSIONS

Width: 140 cm - Inch 55.1
Repeat: 26 cm - Inch 10

CARE

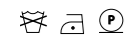

COMPOSITION

42%AC 22%SE 20%VI 16%LI

USE

Light & decoration



TX164
ICE



TX165
SILVER/GOLD



TX166
AZURE

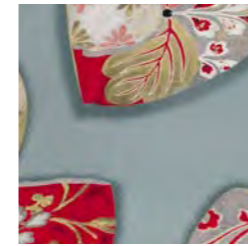

ER062
SAGE/RED/GOLD

SINGAPORE

CAT. E - TE032

Singapore features a design with Eastern-inspired fans depicted with realism on a light jacquard. Floral motifs are represented with vivid touches of red and gold, and refined by black and silver. Details in contrast with the even sage hue of the background. The three-dimensional effect is emphasized by the addition of a shade effect around the edges of the fans. Singapore is presented in a single colour variant.



FULL WIDTH

DIMENSIONS

Width: 146 cm - Inch 57.5
Repeat: 136,8 cm - Inch 53.9

CARE



COMPOSITION

100%PL

USE

Light & decoration

RECANATI

CAT. E - TE030

A striking composition of calla lilies alternates with a macro alligator scales design, almost giving the illusion of flowers growing on a stone wall. The volume of calla lilies is given by a special weaving process that makes the flowers three-dimensional compared to the flat background, where lines defining the animalier texture are entirely embroidered. The repeat refers to the flowers only.



HALF WIDTH



TX167
SILVER/GOLD



TX168
IVORY/ICE



TX169
AZURE/MELON



SINGAPORE Detail



SUVA Detail

SUVA

CAT. E - TE031

Suva presents the same inspiration of Surabaya, but with a shinier and more defined design: an aerial view of an Asian landscape, with water canals and rice fields. The plain satin inserts add a refined touch to this elegant fabric. The colour palette includes a neutral tone as well as bright green and blue options.

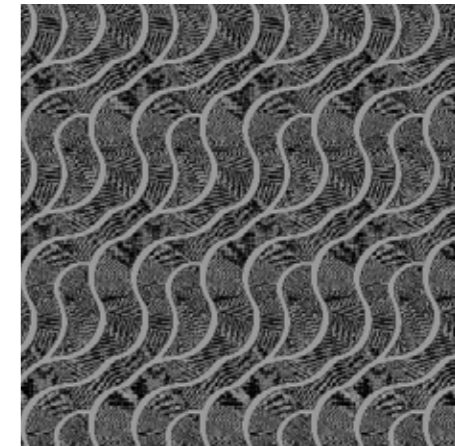

FULL WIDTH

DIMENSIONS

Width: 140 cm - Inch 55.1
Repeat: 45 cm - Inch 17.7

CARE

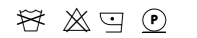

COMPOSITION

42%VI 22%SE 21%AC 15%LI

USE

Light & decoration



TX175
PALE GOLD

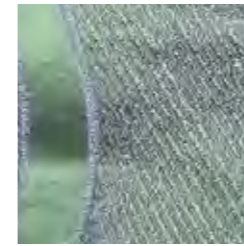

TX176
VIRIDIAN

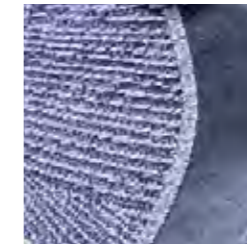

TX177
INDIGO

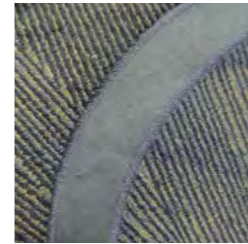

TX178
STEEL BLUE

LAFAYETTE

CAT. S - TS076

Jacquard fabric with decorative landscape motif, woven on silk with precious chenille weft. The design is created on the basis of a Rubelli's archive document, a Japanese hand painted velvet dating back to the early XX century. The Smoked Grey colour is an Armani/Casa stores exclusive and is available on the Dalia chair and decorative cushions only.



HALF WIDTH

DIMENSIONS

Width: 135 cm - Inch 53
Repeat: 105 cm - Inch 41

CARE



COMPOSITION

51%P 27%CO 14%SE 8%PC

USE

Light & decoration



TR853
PALE GOLD/ICE



TR854
NICKEL/BEIGE

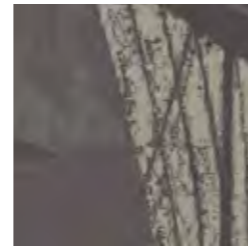

TR855
SMOKED GREY



CANNES

CAT. T - TT002
Fabric for curtains.

DIMENSIONS
Width: 160 cm - Inch 62
Repeat: -

CARE
   

COMPOSITION
100%PL Trevira CS

USE
Sheers and drapery



TR209
IVORY

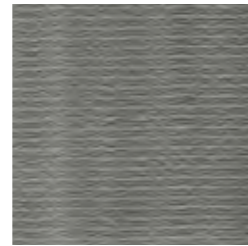

TR210
LIGHT GREY

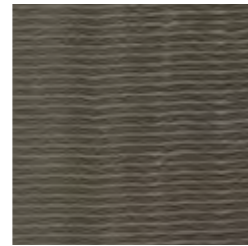

TR211
DOVE GREY







TR212
TOBACCO

CANTERBURY

CAT. T - TT004
Fabric for curtains.

DIMENSIONS
Width: 300 cm - Inch 118
Repeat: -

CARE
    

COMPOSITION
100%PL Trevira CS

USE
Sheers and drapery



TR215
IVORY

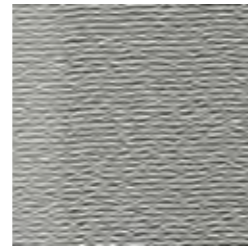

TR216
DOVE GREY

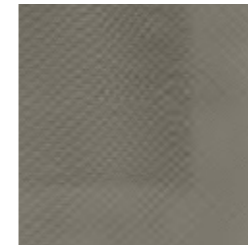

TR206
SAND



TR207
TOBACCO

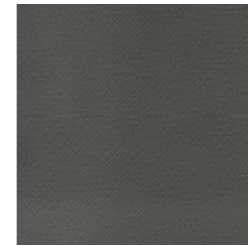





TR208
ANTHRACITE
GREY

CHELSEA

CAT. T - TT001
Fabric for curtains.

DIMENSIONS
Width: 165 cm - Inch 64
Repeat: -

CARE
   





COMPOSITION
100%PL Trevira CS

USE
Sheers and drapery

DUISBURG

CAT. T - TT006
Fabric for curtains, whose high percentage of linen ensures a natural look.

DIMENSIONS
Width: 330 cm - Inch 129
Repeat: -

CARE
   

COMPOSITION
83%LI 17%PL

USE
Sheers and drapery



TR378
IVORY



TR379
SAND



TR380
DOVE GREY

FRISCO

CAT. T - TE017

The pattern is based on the hexagonal shape and takes inspiration from the fashion world, more precisely from neckties.



TR578
ICE



TR579
PEARL

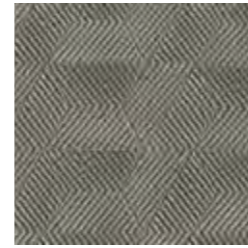

TR580
SILVER

DIMENSIONS

Width: 140 cm - Inch 55.1
Repeat: 6 cm - Inch 2

CARE

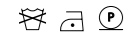

COMPOSITION

100%SE

USE

Sheers and drapery

HONG KONG

CAT. T - TT022

Fabric for curtains. Transparent tone-on-tone layers of silk create a shimmering look and the sophisticated damier pattern.



TR743
IVORY



TR744
BRONZE



TR745
BLUE SHADOW

DIMENSIONS

Width: 140 cm - Inch 55.1
Repeat: 34 cm - Inch 13

CARE



COMPOSITION

100%SE

USE

Sheers and drapery

HANOVER

CAT. T - TT019

Fabric for curtains. Since the fabric is presented in double height, it can be used rotated of 90° depending on need/ personal taste.



TR734
PEARL



TR736
COPPER

DIMENSIONS

Width: 325 cm - Inch 327
Repeat: -

CARE

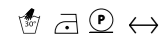

COMPOSITION

51%PL 31%PC 14%CO 4%LI

USE

Sheers and drapery



TR925
ICE



TR926
PALE GOLD



TR927
SMOKED GOLD

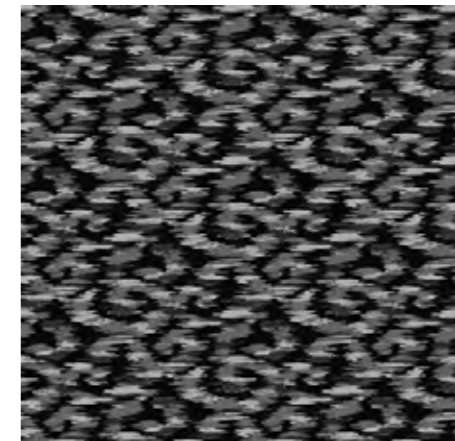

HALF WIDTH

MAJORCA

CAT. T - TT024

Fabric for curtains. The intertwined effect is created on this sheer fabric by augmenting and reducing transparency.

DIMENSIONS

Width: 320 cm - Inch 126
Repeat: 7 cm - Inch 3

CARE

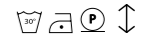

COMPOSITION

50%LI 50%PL

USE

Sheers and drapery

MARSEILLE

CAT. T - TT025

Fabric for curtains. The blurred and faded effect of this curtain fabric is created with linen yarns and different weaving patterns. Since the fabric is presented in double height, it can be used rotated of 90° depending on need/personal taste.

DIMENSIONS

Width: 320 cm - Inch 126
Repeat: 63 cm - Inch 25

CARE

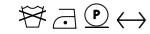

COMPOSITION

57%LI 43%VI

USE

Sheers and drapery



TR929
WHITE



TR930
PEARL

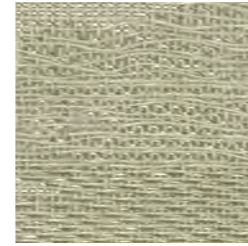

TR931
PALE GOLD

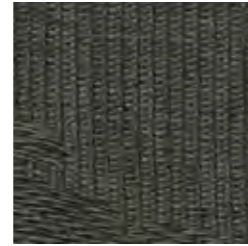

TR932
SEPIA

MONTE CARLO

CAT. T - TT023

Fabric for curtains. Vertical and horizontal basket weave was the source of inspiration for this three-dimensional structure created with a matelassé technique. Flame retardant.

DIMENSIONS

Width: 300 cm - Inch 118
Repeat: 2 cm - Inch 1

CARE

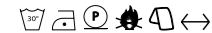

COMPOSITION

70%PL flame retardant 30%PL

USE

Sheers and drapery

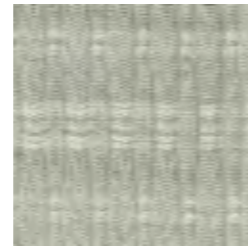

TR922
ICE



TR923
GOLD/IVORY

OHIO

CAT. T - TT028

Fabric for curtains, featuring a texture with interrupted lines in relief. The fabric is presented in double height, so it can be used rotated of 90° depending on need/ personal taste.

DIMENSIONS

Width: 290 cm - Inch 114
Repeat: 68 cm - Inch 27

CARE



COMPOSITION

100%PL Trevira CS

USE

Sheers and drapery

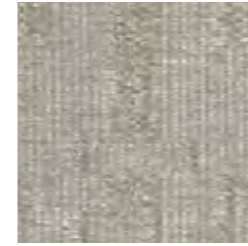

TX109
PEARL

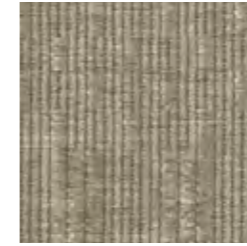

TX110
GOLD

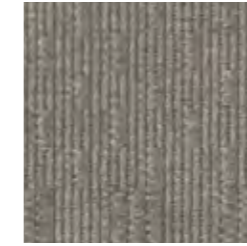

TX111
BRONZE

OSTRA

CAT. T - TT029

Fabric for curtains, featuring a tatami-inspired texture developed with shiny and matt wefts. The fabric is presented in double height, so it can be used rotated of 90° depending on need/personal taste.

DIMENSIONS

Width: 300 cm - Inch 118
Repeat: -

CARE



COMPOSITION

100%PL Trevira CS

USE

Sheers and drapery



TX112
IVORY



TX114
PEARL



TX115
ANTHRACITE/BRONZE

PHILADELPHIA

CAT. T - TT031

The design of Philadelphia comes from the large windows of skyscrapers: regular rectangles are embroidered to create a light grid, a discrete checkerboard that recalls the façade of those buildings. The concept of lightness is emphasized by the use of different colors for the embroidery of the grid, used in order to create irregularities in the hue and the width of the lines. This fabric is entirely hand-woven.

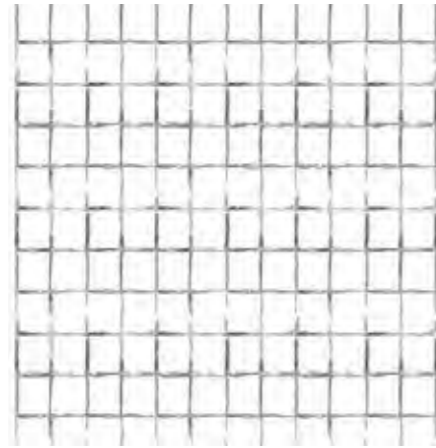

HALF WIDTH

DIMENSIONS

Width: 130 cm - Inch 51.2
Repeat: 40 cm - Inch 16

CARE

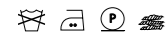

COMPOSITION

85%VI 15%SE

USE

Sheers and drapery

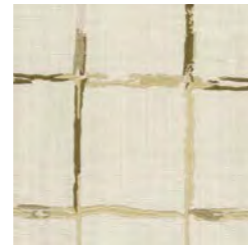

TX141
IVORY/GOLD

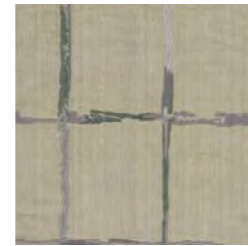

TX142
GOLD/WATER

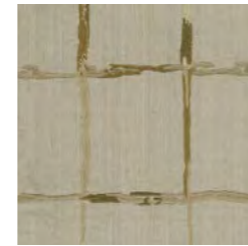

TX143
GOLD/RUST

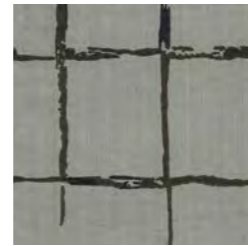

TX144
AZURE/EARTH

PIACENZA

CAT. T - TT030

Piacenza is a tribute to Giorgio Armani's home town. The antique city - rich in palaces, churches and typical Italian squares - is surrounded by a beautiful countryside, whose colors inspired this fabric: the palette recalls all seasons of the landscape, depicting the changing colors of fields, trees, sky and views filtered by the fog.

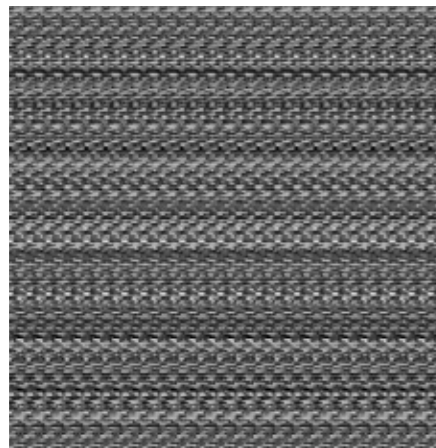

HALF WIDTH

DIMENSIONS

Width: 140 cm - Inch 55.1
Repeat: 6 cm - Inch 2

CARE

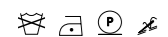

COMPOSITION

68%AC 32%PA

USE

Sheers and drapery

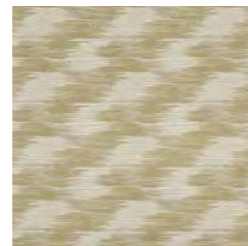

TX121
IVORY/GOLD



TX122
GREY/SILVER/GOLD



TX123
ROSE/SILVER/GOLD

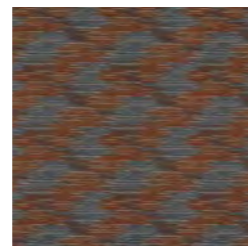

TX124
PETROLEUM/PEACH

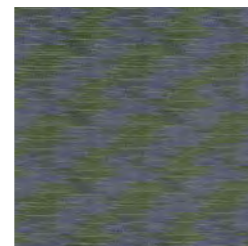

TX125
GREEN/BLUE



SALINA

CAT. T - TT032

Salina is a fabric suitable only for curtains. This light fabric introduces a novelty into the Armani/Casa collection, since it is bourette silk coloured only by using vegetable hues. Salina is characterized by a very soft touch and is particularly crease-resistant. The two colour variants are easy to match with other fabrics from the Armani/Casa collection.

DIMENSIONS

Width: 140 cm - Inch 55.1
Repeat: -

CARE



COMPOSITION

100%SE

USE

Sheers and drapery



ER066
SAGE



ER067
MINT

LIGHT & DECORATION		
ITEM	DESCRIPTION	PAGE
TC053	CANBERRA	315
TC052	COLVILLE	314
TC065	EDMONTON	316
TC090	HAVANA	317
TC096	LYON	318
TC101	NÎMES	319
TC102	NICE	319
TC107	PORTOFINO	323
TC112	SANTIAGO	325
TD061	JUSO	330
TD064	JAIPUR	329
TD077	NOLA	331
TD078	NORFOLK	332
TD079	NOTO	332
TD082	OKINAWA	333
TD085	RIVOLI	335
TD086	ROSTOV	336
TD087	SURABAYA	339
TD097	LANGSA	331
TE024	NAGANO	340
TE025	NANJING	341
TE027	PORTO	343
TE028	PORTLAND	341
TE029	RAVENNA	344
TE030	RECANATI	344
TE031	SUVA	347
TE032	SINGAPORE	345
TS076	LAFAYETTE	348

REGULAR		
ITEM	DESCRIPTION	PAGE
TB048	DENVER	310
TB061	PERUGIA	311
TB062	REIMS	312
TC054	DECATUR	315
TC103	ORLANDO	320
TC113	SAO PAULO	325
TD065	JACKSON	329
TD084	PECHINO	324

HEAVY		
ITEM	DESCRIPTION	PAGE
TA038	PARMA	304
TA039	RIGA	305
TA040	RAVENSBURG	305
TA041	ROUEN	306
TA043	SIRACUSA	309
TA044	SALISBURGO	309
TB056	GENT	311
TB058	GABY	310
TB060	PISA	312
TB063	SIENA	313
TC060	DORCHESTER	316
TC074	ENGLAND	317
TC094	LUXEMBOURG	318
TC104	OSLO	321
TC105	OLBIA	320
TC106	OULU	321
TC108	PALERMO	322
TC109	PANAMA	322
TC110	STOCKHOLM	326
TC111	SIVIGLIA	326
TD049	FARNESE	328
TD056	GRUMELLO	328
TD088	SAINT MORITZ	327

FURNITURE
FINISHING

WOODS
STONES
METALS
SHELLS AND NATURE-INSPIRED
FINISHES
STRAW AND INTERTWINED
PATTERNS
DECORATIONS AND LACQUERS
LEATHERS
TECHNICAL MATERIALS



MAPLE

Our maple features veneer coming from plants belonging to the Acer genus. On the black version, the typical narrow streaks of this wood are emphasized by the glossy finish. Area of origin: Europe.



BLACK MAPLE



HONEY MAPLE

OAK

Oak (*Quercus petraea*) is probably the most popular essence for furniture. The Armani/Casa collection features different versions of this wood, from the classic brushed ones to the most particular finishes. Antique Brown Oak - used as solid wood only - has an irregular surface, colored thanks to an advanced high-pressure technique that injects the pigments directly into the wood mass, so that they can permeate all fibers even inside. All oak versions in our collection are matt and covered by a layer of transparent protective paint. Area of origin: Europe.



ANTIQUÉ BROWN OAK



BRUSHED BROWN OAK

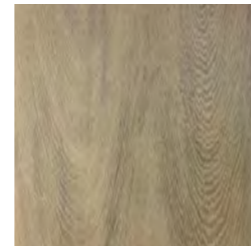

BRUSHED GREIGE OAK



HAZELNUT OAK

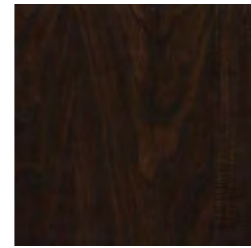

VINTAGE BROWN OAK

ASHWOOD

Ashwood (*Fraxinus spp.*) is marked by clearly visible streaks, which create an exceptional visual impact. Shiny Beige Ashwood is made precious by a layer of glossy lacquer to emphasize the light and shade effect of the neutral hue. The other versions - Brushed Black / Brown / Honey Ashwood - play around strong three-dimensional effects: a heavy brushing phase gives the surface a typical irregular appearance that highlights the natural veins of the material. The wood is finally covered with a protective layer of transparent matt dye. Area of origin: Europe.



BRUSHED BLACK ASHWOOD

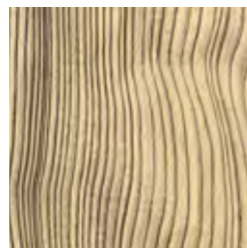

BRUSHED HONEY ASHWOOD



BRUSHED BROWN ASHWOOD

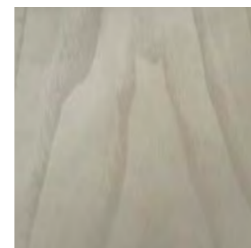

SHINY BEIGE ASHWOOD

WALNUT

Walnut is present within our collection in its American version (*Juglans nigra*): the name 'canaletto' comes from Italian and it is due to the tiny canals visible into the wooden texture, which transport sap inside the plant. Area of origin: North America.



CANALETTO WALNUT

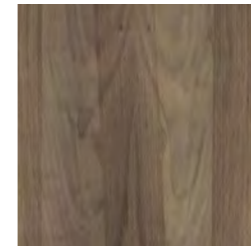

CARVED WALNUT

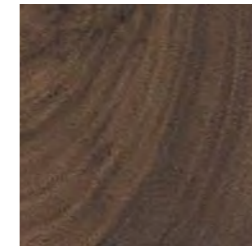

NATURAL CANALETTO WALNUT

CLASSIC AND EXOTIC ESSENCES

The Armani/Casa collection is rich in many woods varying in color, texture and origin. Among the classic ones, Brown Elm features a glossy surface; Black Larch presents beautiful contrasted veins with a luxurious shiny finishing; Olive - an uncommon essence in home environments - underlines the deep bond of our brand to the Mediterranean.

Exotic essences count well-known precious woods like African mahogany (*Entandophragma utile*), macassar ebony (*Diospyros celebica*), shiny rosewood from South America (*Machaerium scleroxylon*), palm (*Iriarte deltoidea*). All those essences do not need any CITES documentation, since they do not come from endangered species: this is an ethic choice that Armani/Casa pursues in order to fulfill the Corporate Social Responsibility of the Armani Group.



BLACK LARCH

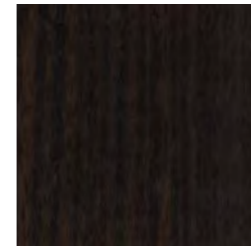

BROWN ELM



BROWN MAHOGANY

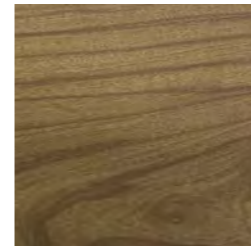

OLIVE



PALM

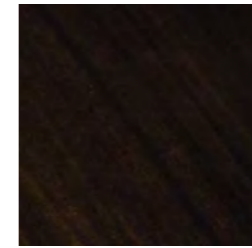

SHINY SANTOS ROSEWOOD

TAMO

Tamo (*Fraxinus mandshurica*), also known as Japanese ashwood, has become an iconic material for Armani/Casa thanks to its Oriental appeal. Native of Manchuria, it was later transplanted in the mountainous regions of Japan, where the rare «peanut-shell figured» grain variety is now exclusively cultivated. Available in three different colors, the unmistakable texture of this wood perfectly matches with the pure lines of our furniture. Area of origin: Japan.

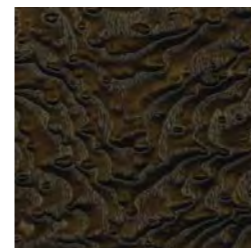

BROWN TAMO

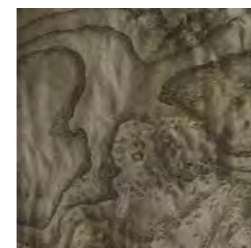

DOVE GREY TAMO

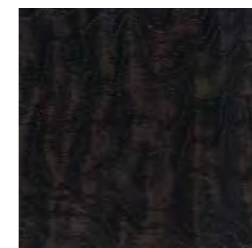

GREY TAMO

SPECIAL WOODS

Black-Ocre Carving is marked by a beautiful three-dimensional appearance. The design is obtained by an irregular carving at multiple levels, in order to create different thicknesses of the wood. This effect is emphasized by the use of two contrasting tones: the whole black surface is carved and the resulting lines in relief are then lacquered in ocre.

Paulownia (*Paulownia tomentosa*) is a particular specimen commonly known as royal paulownia or empress / princess tree, due to its majestic appearance and its fragrant flowers. Paulownia wood is particularly appreciated for being flexible and elastic, which - together with an even structure and a high resistance to humidity - makes this lumber extremely suitable for furniture and high-precision works. Thermo-treated Paulownia owes its name to the heating process applied on the raw veneer, which enhances the beautiful contrast of the streaks. Carved Paulownia, instead, is characterised by a three-dimensional surface recalling the iconic *canneté* texture typical of the Armani aesthetics, emphasized by its natural warm color. Area of origin: Italy.

Grey Arboreo suggests a deep link to the world of Nature: the Italian 'arboreo', in fact, indicates something related to trees. Thanks to an advanced high-pressure technique, the color is injected directly into the wood mass, so that it can permeate all fibers even inside. The surface is then covered with a shellac finishing. This environment-friendly material can vary a lot depending on the essence undergoing this special coloring process. Area of origin: Italy.



BLACK-OCRE CARVING



CARVED PAULOWNIA

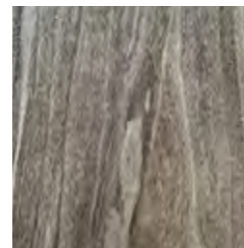

GREY ARBOREO



THERMO-TREATED PAULOWNIA

STONES

Stones are a very important element in the Armani aesthetic philosophy, since they are they are the ultimate expression of Nature's beauty and eternity. Armani/Casa uses the most astonishing stones in the world for its collections, selecting every slab individually to find the best possible hue and design. Examples of this research are Emerald Quartzite from Brazil, Grey Marble from Colombia, Selenite from Morocco and Sodalite from Bolivia.

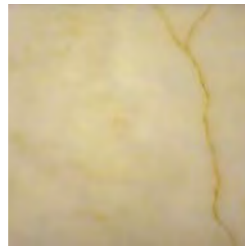

ALABASTER

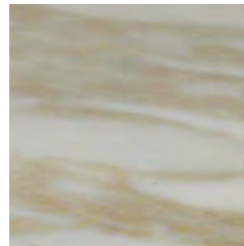

CALACATTA ORO MARBLE

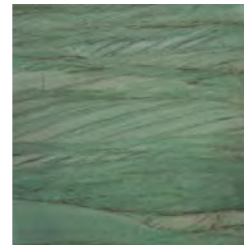

EMERALD QUARTZITE

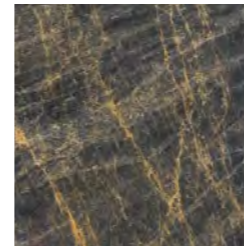

GREY COLOMBIAN MARBLE



LIMESTONE



SELENITE

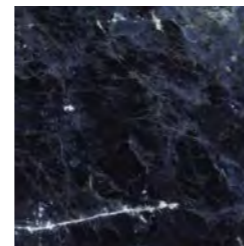

SODALITE

METALS

Always aiming to create the best chromatic harmony, Armani/Casa offers several colors of metals to perfectly match all other finishes in collection. Golden tones, in particular, are typical within the Armani/Casa palette. Each metal is characterized by a different treatment of the surface (satin or glossy) and shows a modern or a vintage look. Satin Light Brass is entirely hand polished to obtain its typical appearance.

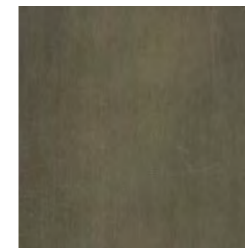

BRONZED BRASS



GLOSSY NATURAL BRASS



SATIN LIGHT BRASS

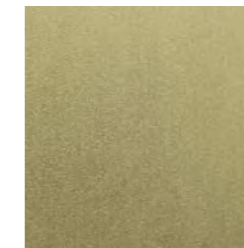

SATIN NATURAL BRASS



BLACK PAINTED STEEL



SATIN BLACK NICKEL

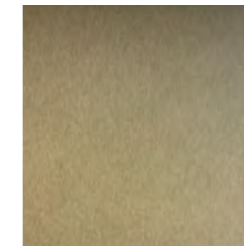

SMOKED GOLD

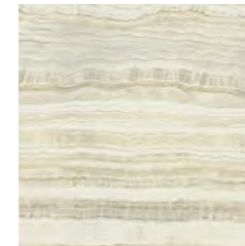

ONYX-TEXTURED METAL

SPECIAL METALS

The use of metal - and other exclusive finishes imitating this material - is a signature element of Armani/Casa. Onyx-Textured Metal combines metal with another element typical of our brand, onyx, Giorgio Armani's favorite stone because of its tone-on-tone striped design. An advanced ink printing technology is used to replicate the onyx pattern: in this way, the design "penetrates" the metallic surface so that it can become more vivid and resistant.

SHELLS

Shells are the perfect example of how Armani/Casa can transform the beauty of Nature into astonishing finishes. Black Opal Shell features a rich texture given by the pearlescent surface of shells, assembled together to create a mosaic playing on a dark shiny base: touches of scarlet red, metallic green and cobalt blue merge in an infinite kaleidoscope, recalling the typical effect of a precious black opal. Green Spotted Shell, on the other hand, plays on a solid turquoise ground with shades of green and ivory, where the small irregular spots recall an animalier texture evoking almost an exotic inspiration. Marine Pen Shell is made in Indonesia, where skillful artisans treat pen shells to obtain an alternating black/grey striped design. Finally, Shell Mosaic features mother-of-pearl tiles.

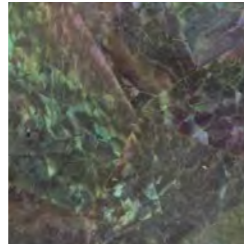

BLACK OPAL SHELL

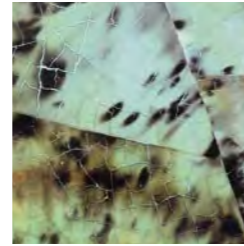

GREEN SPOTTED SHELL



MARINE PEN SHELL



SHELL MOSAIC

LINEN

The Armani/Casa collection features several decorative finishes inspired by the naturalness of linen.

Kyoto Texture is made with real linen fabric in natural color featuring dark red lacquered inserts.

Lacquered Red Linen features linen fabric coupled with gold leaf and then painted in red, where a layer of transparent lacquer adds the final shiny touch leaving the textured surface visible.

Patinated Linen is obtained by glueing natural linen fabric on a wooden support: after that, silver leaf is carefully applied before spraying the patina. This patina causes silver and linen to blend: the final result is an exclusive finish that acquires a textured golden tone, evoking the worlds of textiles and jewelry at the same time. A final layer of transparent protective resins is sprayed on the surface.

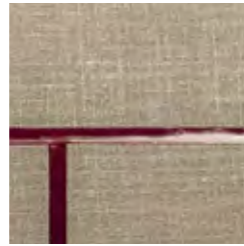

KYOTO TEXTURE



LACQUERED RED LINEN



PATINATED LINEN





STRAW MARQUETRY

This unmistakable finish has become an Armani/ Casa signature through the years. The origins of this technique are very ancient: first traces of straw marquetry can be found in Far East countries and date back to the Middle Age. Only after the late XVII century this decoration motif spread in central Europe, becoming very popular especially in France. During the Art Déco period, it was used for the first time to decorate luxury furniture.

The process to obtain this finish is entirely hand made and requires several steps in which the skill of the artisan is crucial: from the cutting of rye straws to their flattening, from their glueing to the final polishing, everything must be carefully done to obtain the breath-taking look typical of this precious material. Available in different colors and designs, straw marquetry is also proposed in a lacquered version (Shiny Bronze Straw Marquetry) to make it suitable for the top of the Nelson dining table; on this product, the marquetry creates an all-over design.



BLACK STRAW MARQUETRY

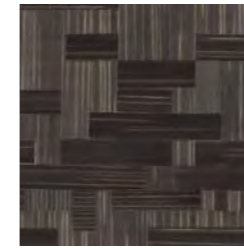

BRONZE STRAW MARQUETRY

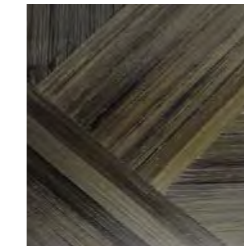

SHINY BRONZE STRAW MARQUETRY



CRISSCROSS NATURAL STRAW

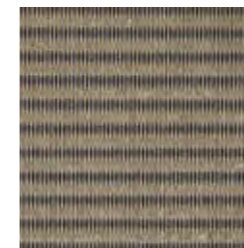

NATURAL-BLACK TATAMI



HAZELNUT MIDOLLINO

INTERTWINED PATTERNS

Crisscross Natural Straw is obtained using a base panel covered by vertical rye straws, contrasting with the horizontal ones glued to leave the background visible. The alternance of vertical and horizontal stripes affects the way light hits the surface, giving back several tones of gold and brown that change depending on the angle of view. The finish is covered by a layer of matt transparent paint to make the surface smooth and more resistant. Like marquetry, this finish requires many hours to be completed: the straws are carefully glued one by one to create the intricate pattern.

Natural-Black Tatami is a textured material obtained by weaving paper yarns around a core of resistant cotton strings. The tatami-inspired surface is marked by a three-dimensional motif, recalling a *canneté* effect thanks to the two contrasting colors: these features create a strong link to the world of fashion and Japanese culture at the same time.

Hazelnut Midollino, with its woven detailing, features a three-dimensional texture obtained through the traditional artisanal technique of wicker.

HAND MADE / HAND PAINTED LACQUERS

These lacquers represent the highest level of artisanship and are deeply linked to art.

Caribbean Lacquer is obtained by applying three layers of different colors on the same surface: the paint is later removed in specific areas in order to show the contrasting hues underneath, creating irregular stripes with blurred borders. The whole process is hand made.

Golden Sea Waves Lacquer, instead, presents golden hand painted streaks on a shellac ground, recreating a play of reflections on water half way between the softness of Impressionism and the luster of Art Déco.

Sky Lacquer is entirely hand painted and reinterprets the hues of the *Cloud Studies* that the English painter J. Constable (1776-1837) painted as a tribute to his homeland.

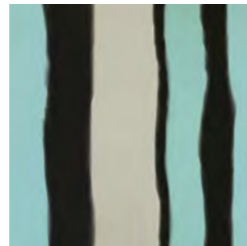

CARRIBEAN LACQUER



GOLDEN SEA WAVES LACQUER



SKY LACQUER

DECORATIVE RESINS

Ivory and black, two sides of the same elegance envisaged by Giorgio Armani. The neutral tones of the first blend in the velvety essence of the second, creating a stunning three-dimensional finish for Armani/Casa. Inspired by the delicate brightness of the moon and its reflections on water and clouds, the Moonlight Decoration enchants with its dégradé effect, as well as with the uneven appearance: circles, carved in the resin to imitate the concentric ripples created by drops, add movement to the surface resembling water mirroring the night sky.

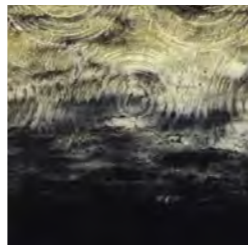

MOONLIGHT DECORATION





BLACK DRAFTED STUCCO



MUD DRAFTED STUCCO



RED DRAFTED STUCCO



WHITE GOLD DRAFTED STUCCO



WHITE GOLD STRIPED STUCCO

STUCCO

This typical wall decoration technique has been reinterpreted by Armani/Casa with the creation of these precious finishes. The drafted versions, available in four colors, are obtained by creating an irregular grid on wet stucco; once dry, the surface is finished with a protective layer of glossy lacquer.

White Gold Striped Stucco, instead, is the result of the combination of three different elements: a carved wood panel featuring a striped design reminding the *cannetè* texture of fabrics, a layer of natural stucco and a final application of silver leaf.



ANTIQUE GOLD LEAF



WHITE GOLD LEAF



ROSE SILVER LEAF

GOLD AND SILVER LEAF

The art of gilding is very ancient: Egyptians used to gild wood and metals, and also Greeks knew a similar technique. The extensive use of gilding spread especially during the Roman Republic period and continued for all the following centuries, becoming a typical decoration for jewelry, statues, picture frames, paper art, small objects, architectural details and luxury furniture. The gilding of Armani/Casa furniture is a completely hand made process, which is carried out thanks to the skill of artisans applying the thin metal sheets (0,2 micron thickness) on wood with the aid of a brush and a wet sponge only.

Gold leaves are made with real 12-karat gold and are available in two tones, from a very pale and delicate white gold to a more vintage tone; silver leaf, is presented in a romantic rosé version enriched by a touch of copper.

LIQUID METAL

Liquid metals are a new generation of lacquers featuring real metal pigments, which give the finishes a distinctive look: in fact, all these materials present a typical reflectance and a cold touch resembling the one of real metal. Depending on the support – carved, brushed or perfectly even – and the desired hue, it is possible to obtain different effects. On ash, for example, it is possible to appreciate the natural veins of wood below the silver lacquer, while the carved versions create the illusion of vintage metal rods.



BRASS CARVED LIQUID METAL

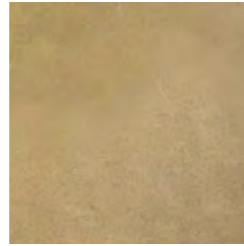

GOLD LIQUID METAL



LIQUID METAL ASHWOOD

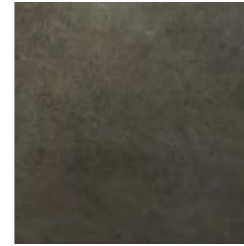

PATINATED LIQUID METAL

SHELLAC

These lacquers are available in vivid colors, highlighted by the homogeneous surface covered with a shellac finishing.



DARK BLUE LACQUER



FOREST GREEN LACQUER



JAPAN RED LACQUER



RED LACQUER

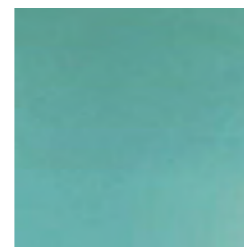

VERONESE GREEN LACQUER

TEXTURED AND METALLIC LACQUERS

Many of the lacquers by Armani/Casa show a distinctive look, given by the texture or the metallic shine of the surface. Egypt Lacquer is a perfect example, since it is the result of the combination of three different techniques: after being painted to recreate a laminated look, a technical fabric is crumpled, glued on the supporting panel and lacquered. Among others, we can mention crackled lacquers – reproducing the crackled surface of precious vintage objects – and lacquers inspired by metals.

Black Striped Lacquer adds a carving to the surface of our usual black lacquer to recreate a three-dimensional *canneté* look. The carved lines do not continue on the whole wideness of the lacquer, hence giving the illusion of a fading design. The width and the length of the lines can vary from piece to piece, since they are obtained thanks to an artisanal production process.

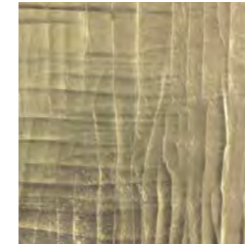

EGYPT LACQUER

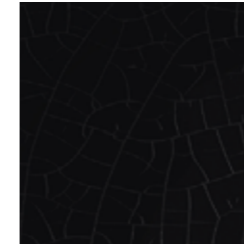

BLACK CRACKLED LACQUER



IVORY CRACKLED LACQUER



GREIGE STRIPED LACQUER



METAL LACQUER



METALLIZED DARK GREEN LACQUER

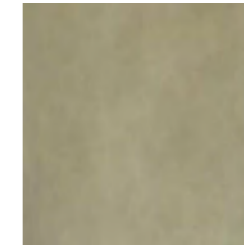

PLATINUM LACQUER



STRIPED BLACK LACQUER



LEATHERS (CUOIO)

'Cuio' is the thick leather of the Italian tradition, typical of central regions such as Tuscany. Due to its thickness, this cow leather is available only on some products like some chairs and desks. The surface of cuio is quite smooth and homogeneous.



BLACK LEATHER
(CUOIO)



COGNAC LEATHER
(CUOIO)



CORTECCIA BROWN
LEATHER (CUOIO)



DARK BLUE LEATHER
(CUOIO)

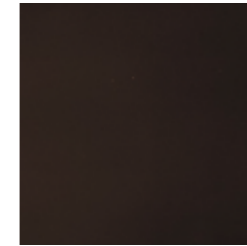

DARK BROWN LEATHER
(CUOIO)



DARK GREEN LEATHER
(CUOIO)



DOVE GREY LEATHER
(CUOIO)

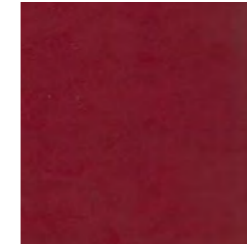

RED LEATHER
(CUOIO)

SOFT TOUCH LEATHERS

Soft Touch Leathers are tumbled cow leathers, showing a distinctive texture. Available in neutral colors, this kind of leather is suitable for upholstered products. Area of origin: Italy.

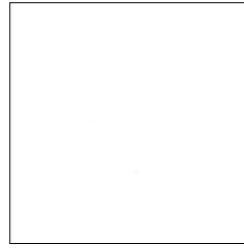

P0401 - ICE

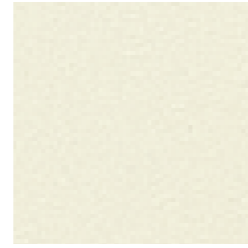

P0402 - IVORY

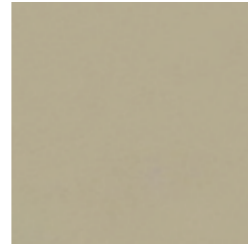

P0404 - SAND

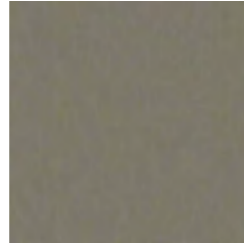

P0405 - LIGHT BROWN



P0406 - DOVE

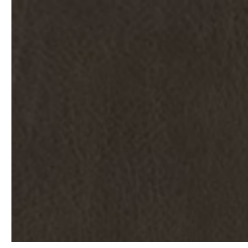

P0407 - BROWN

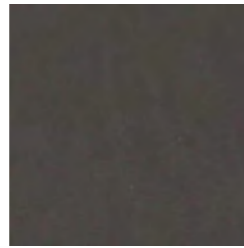

P0408 - GREEN



P0409 - BLACK



P0410 - CHARCOAL



C0014 - NATURAL



C0020 - BLACK

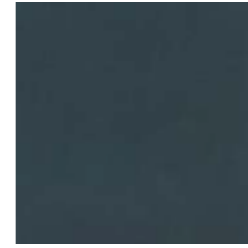

C0034 - BLUE

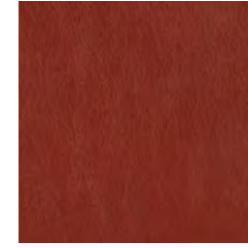

C0062 - ORANGE

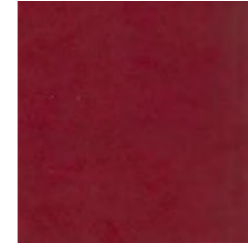

C0074 - RED



C0086 - DARK GREEN



C0151 - COGNAC



C0554 - DOVE GREY



C5286 - WATER GREEN

THIN LEATHERS

Thin Leathers present a reduced thickness compared to Soft Touch Leathers. They are treated cow leathers featuring a smooth surface, where irregular streaks can be visible: this distinctive feature is typical of the natural raw material and highlights its quality. Thin Leathers are available on a selection of products only. Area of origin: Italy.

SHAGREEN-INSPIRED LEATHERS

Shagreen-inspired leathers present a particularly visible texture, added through printing or coating techniques. Among those, we can mention Jade Shagreen Textured Leather: the texture is reproduced through a printing process followed by a hand-brushing which lightens the color in relief. Color and shade can vary from one leather to another.

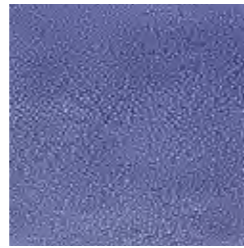

BLUE SHAGREEN EFFECT LEATHER

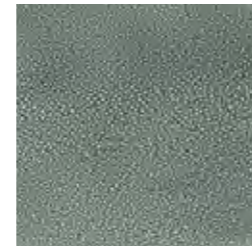

GREEN SHAGREEN EFFECT LEATHER



GREIGE SHAGREEN EFFECT LEATHER



JADE SHAGREEN TEXTURED LEATHER



RED SHAGREEN EFFECT LEATHER

OTHER LEATHERS

Some leathers are developed as exclusive materials for specific products. Vintage Beige and Vintage Brown Leather are respectively available on the Paul and Pascal ranges only, and both are marked by irregularities on the surface due to the preciosity of the material. Red Soft Leather is a top quality leather showing a natural grained surface; it is available on the Margot range only.

Natural Parchment is made by treating goatskin, in the same way required to create parchment paper: irregularities on the surface – like scars or remarkable variations of color and texture – must be considered a defining feature of this finish, since the raw material does not undergo any chemical colouring process.



BEIGE VINTAGE LEATHER



BROWN VINTAGE LEATHER

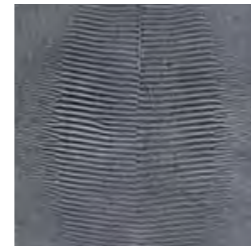

GREY LIZARD EFFECT LEATHER



JAPAN RED SOFT TOUCH LEATHER

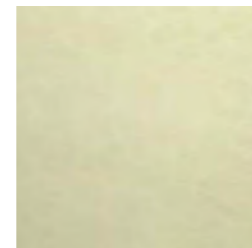

NATURAL PARCHMENT

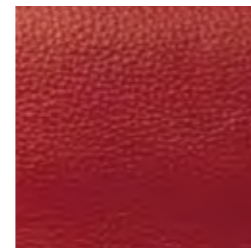

RED SOFT LEATHER

METHACRYLATE

Methacrylate is a high-performing material with unique characteristics: more transparent than glass and very resistant, it can be used to obtain particular effects. The Armani/Casa collection features different versions of this material coupled with metal mesh, where the final color depends both on the hue of the metal itself and the color of methacrylate layers enclosing the mesh. Bronze Mirror Methacrylate features a reflective panel on the back, creating a dark-textured mirroring surface.



BRONZE METHACRYLATE



BRONZE MIRROR METHACRYLATE



GOLDEN METHACRYLATE



TRANSPARENT METHACRYLATE

TECHNICAL FABRICS

Technical fabrics by Armani/Casa are developed on microfiber, which makes them soft and pliable. These materials are stronger than leather on a strength-to-weight ratio but, similarly to leather, their surface features invisible micro pores that can dissipate heat and humidity. Differently from usual fabrics of this kind, they do not contain any PVC: for this reason, they do not release any harmful compounds, thus being safe for use in any environment. Those fabrics are also very resistant to abrasion and provide excellent durability; they even passed the flame retardant test (FR) without any additional treatment.

Depending on the desired effect, these fabrics can undergo different processes to obtain a specific look: Technical Shagreen Fabric, for example, has a custom printed multi-colored pattern created by a tri-axial matrix, conceived to remind the appearance of the precious rawhide typical of the Armani taste. The other versions of technical fabric reproduce the typical streaks on the fur of chinchilla (Technical Chinchilla Fabric) or a warm-toned leather with pearlescent reflections (Technical Pearl Gold Fabric).

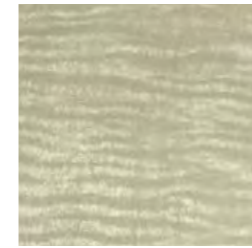

TECHNICAL CHINCHILLA FABRIC



TECHNICAL PEARL GOLD FABRIC

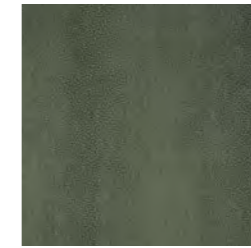

TECHNICAL SHAGREEN FABRIC

ACCESSORIES

- DECORATIVE ACCESSORIES
- GIFTS
- TABLEWARE
- TEXTILES



BATHROOM SETS



HIDALGO



HIDALGO



HIDALGO



VETIVER



SECRET

BOXES



NASTRO



NASTRO



RAFFAELLO



SIRENA



SIRIO



SIRIO



TEORIA



DECORATIVE LIGHTS



HACK



HACK



HOLA



HOLA



MERCI



PEGASO



PEGASO



PEGASO



ROCHA



ROCHA



SEA



SUNNY



SUNNY

HOME FRAGRANCES



HOLA



HOLA



ROLF



SKY



SKY



SKY

CHRISTMAS DECORATIONS

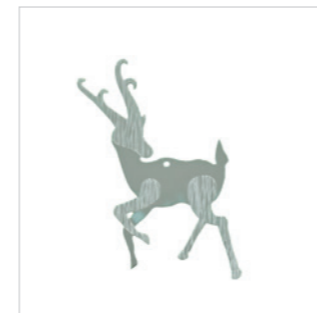

SOAVE

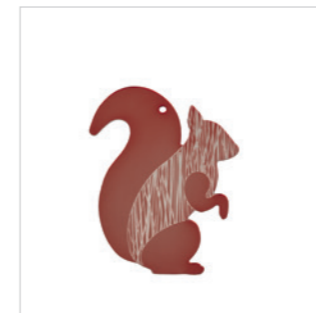

SOAVE

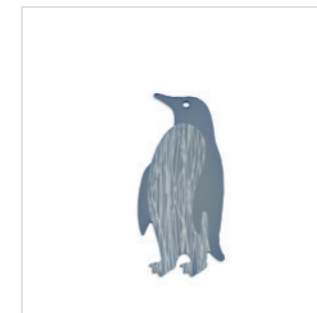

SOAVE



SOAVE

FRAMES

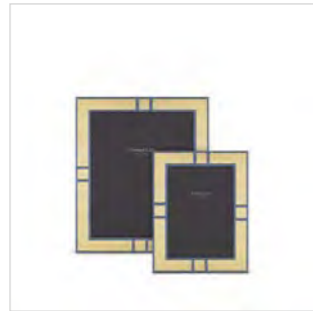

HOLLY

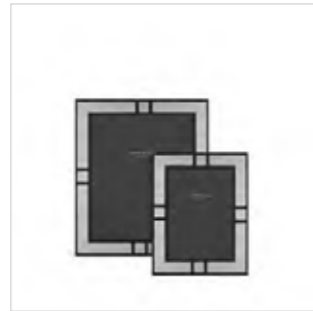

HOLLY



HOLLY



HOLLY



RAFFAELLO



RAFFAELLO



SFINGE



SFINGE



SFINGE



SFINGE



SELENE



SOMEONE

HOME BASKETS AND HOLDERS



CLEO



CLEO



FABBRO



FUMO



GOCCIA



MISTRAL



PEACOCK



PIUMA



SILVIA

SMOKERS' ACCESSORIES



OMAR



SIRENA

VASES



ACHILLE



ALCAZAR

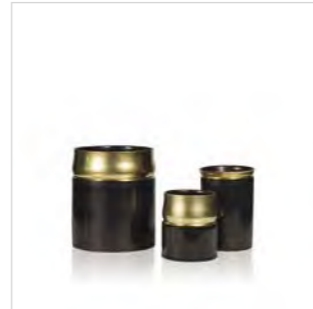

GENTIL

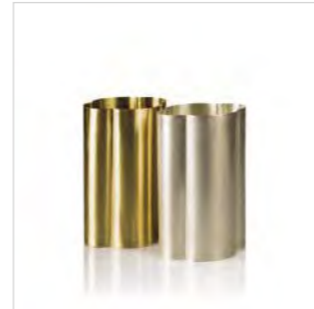

MOVE



ORIANA



ORIANA



PARSIFAL

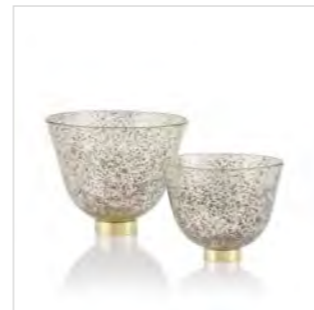

PARSIFAL

TRAYS AND CENTERPIECES



ELIZABETH



ERIKA

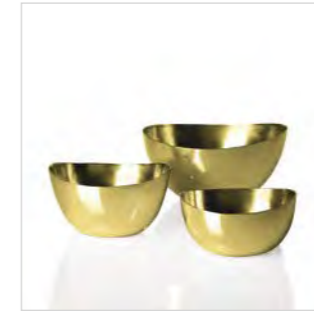

GINGER



GINGER



HIROMI



HIROMI



HIROMI



HIROMI

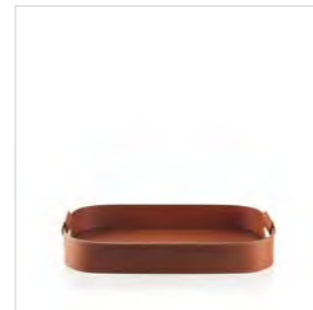

LAURO



LAURO



LAURO



ROMEO



RUFOUS



RUFOUS

GAMES



EUCHRE



FAIR



FAIR



FAIR



HERO



JOE



JOE

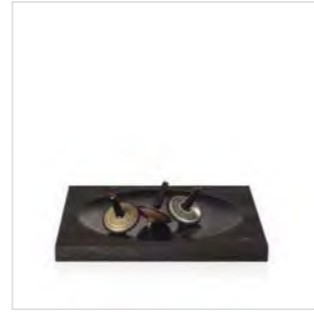

MOON



NARDO



ONEIROS



REGNI



SAETTA



SIR



SPIN



SAMSARA

TRAVEL ACCESSORIES



PIPER

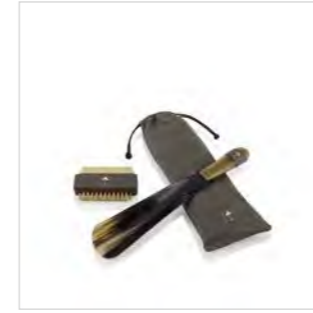

PIPER



REALE



REALE



SALLY



SALLY



SALLY



SCARLETT



SMERALDA

DESK
ACCESSORIES
AND
STATIONERY



EAGLE



HUNTER



JASPER



MALIN



ORWELL



SANZIO

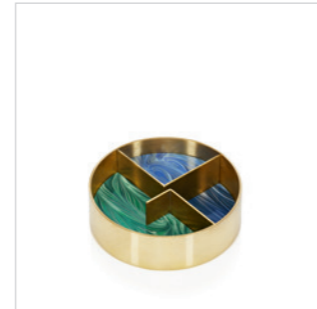

SIGNATURE



SPORT
AND HOME
FITNESS



PLAGE



PLAGE



PUMP



PUMP



PUMP



PUMP

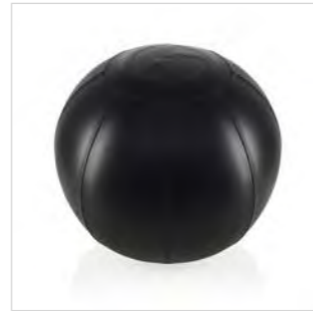

PUMP

OUTDOOR



ROBESPIERRE



ROBESPIERRE



ROBESPIERRE



ROVO



ROWAN



ROWAN



ROWAN



SKIN



SANZIO



SAMBUCO



SNOW



DURER



LOUIS



OCTOBER



ODE



ODE

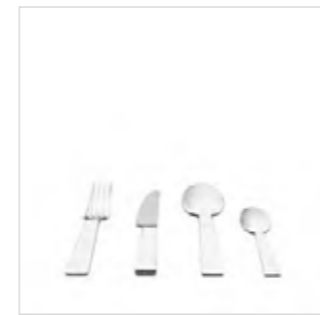

ARPA

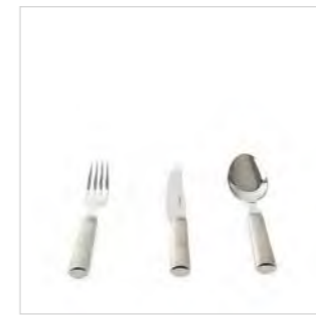

LAUREN



VENERE

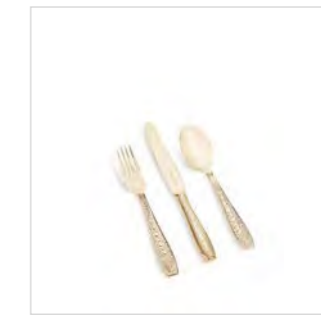

VENERE



PACIFIC



PACIFIC



PACIFIC



PACIFIC



CORELLI



CORELLI



CORELLI



DVORAK



GLORIA



GOMEZ



LORD

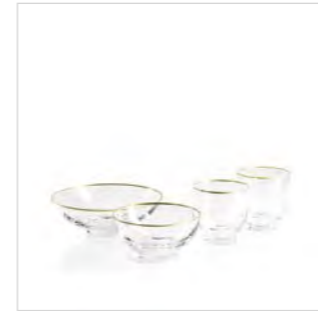

LORD

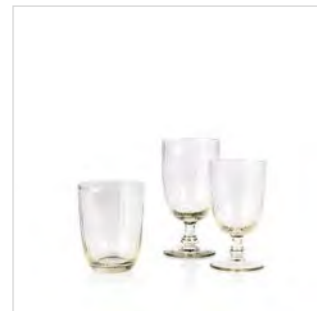

LOULOU



OLATZ



OLATZ



ORSINI



ONORIO



ONORIO



ONORIO



RIVIERE

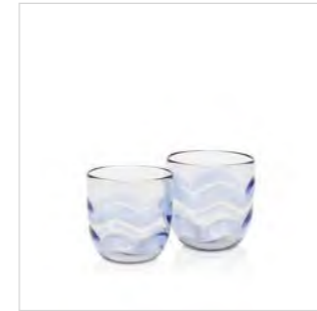

REMO

TEA AND
COFFEE SETS



LOUIS Tea/coffee set



DURER



LOUIS



BAINDOLES



OBELISC



REST

VARIOUS TABLEWARE

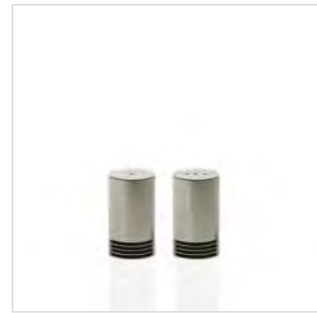

BERLIOZ



EFREM



FUSION



NAIKE



OKURA



OKURA



ORENGO



ORENGO



ORENGO



ORENGO



RUGIADA



RUGIADA

VARIOUS TABLEWARE



ROGER



ROGER



ROGER



RUDOLPH

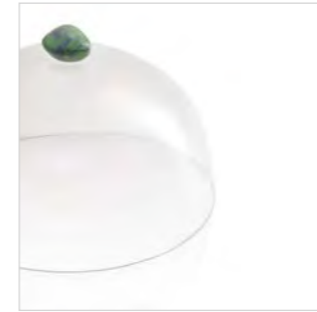

SHOW



SHOW



SHOW



SHOW



SPRING



SWEET

TABLE
TEXTILES



COOL



COOL



ORTENSIA



SARA

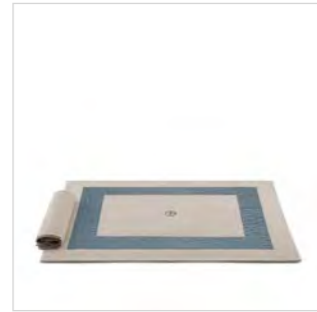

PROTEA

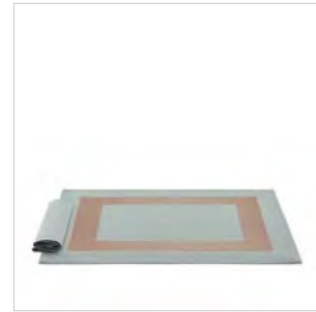

PROTEA



RASPBERRY

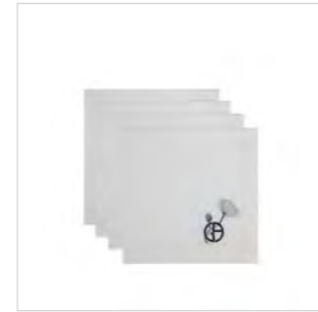

REBECCA

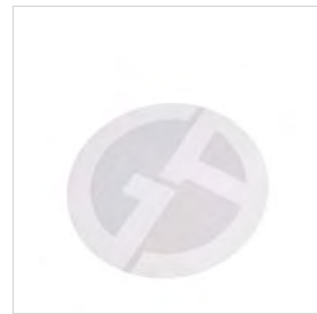

ROBERTA



ROSEMARY



DECORATIVE CUSHIONS



JANETTE



JANETTE



JANETTE



JANETTE



JANETTE



JAPAN



JAPAN



JAPAN



JAPAN

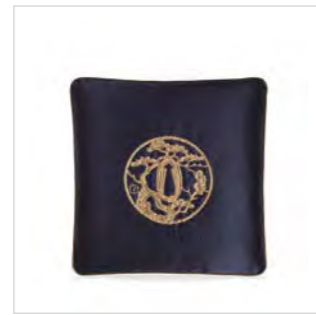

JAPAN



SEOUL

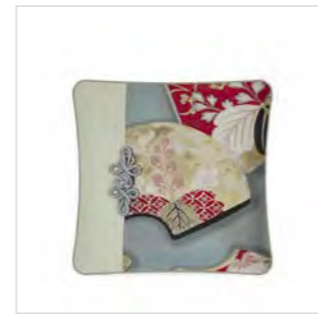

SHANGHAI



NANJING

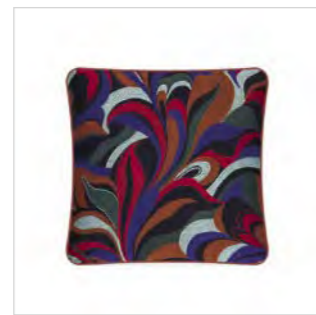

SAO PAULO

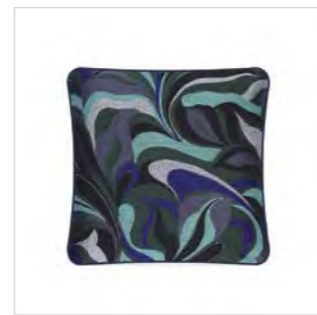

SAO PAULO

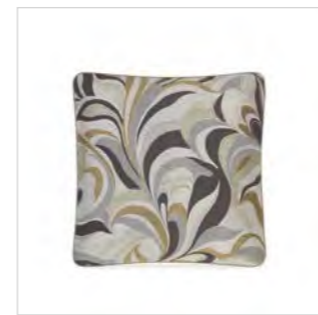

SAO PAULO

DECORATIVE CUSHIONS

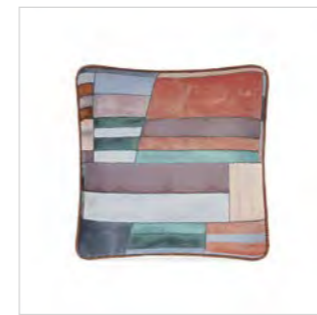

SANTIAGO



SANTIAGO

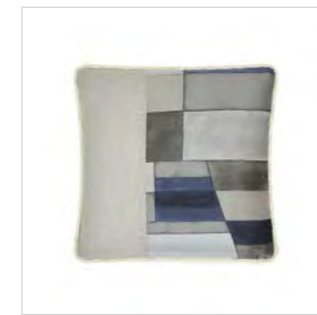

SALOME



SAPPORO



SARAGOZA



SIRMIONE



STRESA



SUVA



SVEVA



SVEVA



SATURNIA



SELMA



SHIRLEY



SIENNA

PLAIDS



EDITORE



OZZY



PENNY

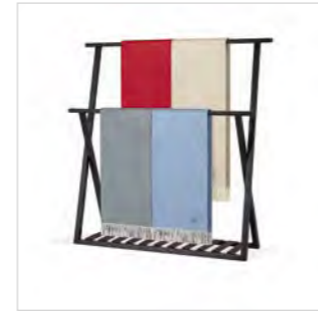

PHOEBE



RAIN



SACHIKO



SELMA



SHIRLEY



SIENNA



SORAYA

BATH



DOROTEA

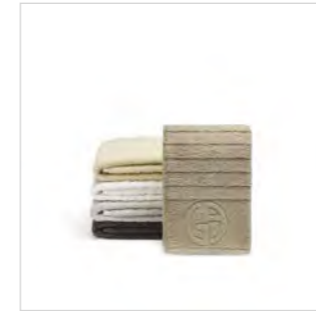

DOROTEA



ROSSELLA



ROSSELLA



PETTY



VIRGINIA

BED LINEN
AND
ACCESSORIES

MADE TO MEASURE HOME TEXTILES

Armani/Casa textiles have always been able to evoke strong tactile and visual impact, expressing the unique aesthetic codes of Giorgio Armani. The result is a home with living areas and bedrooms enriched by precious items that dress different spaces with glamour and elegance.

DOMIZIA

The range of bed sheets and pillowcases Domizia is available in two different fabrics. Both can be customized by adding embroidered initials.

The percale cotton (500 thread count) is available in 6 colors, as well as satin cotton (600 thread count). The sheets can be customized also by choosing among three different borders, all expressing Giorgio Armani's sensibility for fabrics: plissé, contrasting double band and plain à-jour hems. To attain a harmonious and consistent look, the color palette offers suggestions for the best color combinations.

MADE IN ITALY.



RANGE	CATEGORY	PAGE
ACHILLE	Vases	390
AIDA	Wallcovering	256
ALABASTER	Table lamp	208
ALADINO	Floor lamp	194
ALCAZAR	Vases	390
AM AHL	Wallcovering	266
ANDROMEDA	Tub chair	73
ANTOINETTE	Coiffeuse in limited edition	14
ANTOINETTE	Coiffeuse	180
ARMSTRONG	Rug	230
ARPA	Cutlery	399
AURORA	Floor lamp	196
BAINDOLES	Tea/Coffee set	403
BALOO	Armchair and footrest	36
BAR	Tall stool	75
BARBICAN	Armchair and footrest	36
BAX	Rug	230
BAYADÈRE	Wallcovering	264
BELGRAVIA	Wallcovering	280
BERLIOZ	Salt and pepper dispensers	404
BLOOM	Table lamp	208
BOCCHERINI	Small table	100
BOHÈME	Wallcovering	262
BORROMINI	Chaise-longue	44
BRERA	Wallcovering	276
BURT	Rug	231
CADRE	Rug	231
CAMILLA	Desk	146
CANALETTO	Sofa	20
CANALETTO	Modular system	28
CANALETTO	Armchair and footrest	37
CANBERRA	Fabric	315
CANNES	Fabric	350
CANTERBURY	Fabric	350
CAPRI	Wallcovering	294
CARMEN	Wallcovering	266
CASTILLA	Chest of drawers	166
CELEBRITY	Floor lamp	196
CELEBRITY	Table lamp	209
CHAPLIN	Rug	232
CHELSEA	Fabric	351
CHERIE	Table lamp	209
CIMAROSA	Bedside table	118
CIRCLE	Bar cabinet	158

RANGE	CATEGORY	PAGE
CLASSIC	Tub chair	74
CLEO	Umbrellas holder	389
CLUB	Bar cabinet	160
CLUB Black straw marquetry	Bar cabinet in limited edition	10
COLVILLE	Fabric	314
COOL	Placemat and napkins	406
COPPÉLIA	Wallcovering	268
CORELLI	Glassware	400
CRONOS	Rug	232
CROQUIS	Rug	233
DAKAR	Stool	49
DALIA	Chair without armrests	67
DALLAS	Chair with armrests	58
DAMASIO	Bedside table	119
DAMOCLE	Chest of drawers	167
DANDY	Bed	130
DANZICA	Coffee tables	101
DAVID	Chest of drawers	168
DAVID 3	Bedside table	119
DECATUR	Fabric	315
DENVER	Fabric	310
DIOGENE	Table lamp	210
DIVA	Mirror	185
DOMIZIA	Made to measure bed linen	412
DONNA	Table lamp	210
DORCHESTER	Fabric	316
DOROTEA	Bath towels	411
DORY	Table lamp	211
DREAM	Bed	131
DUISBURG	Fabric	351
DURER	Dinnerware	399
DURER	Tea/Coffee set	403
DUSTIN	Director's chair	66
DVORAK	Glassware	400
EAGLE	Vase and paperweight	394
EAST	Bedside table	120
ECCELSO	Rug	233
EDITORE	Plaid	410
EDMONTON	Fabric	316
EFREM	Coasters	404
ELBA	Wallcovering	290
ELIZABETH	Centerpieces	391
EMME	Floor lamp	197
ENGADIN	Modular system	30

RANGE	CATEGORY	PAGE
ENGADIN	Daybed	44
ENGLAND	Fabric	317
ENYA	Console	92
ERIKA	Centerpiece	391
ESAGONO	Small table/Stool	102
ESSEX	Armchair	37
EUCHRE	Cards	392
EUCLIDE	Desk	147
EVANS	Console	93
EXCELSIOR	Multifunctional cabinet	171
EXCELSIOR	Wallcovering	264
FABBRO	Fireplace accessories	389
FAIR	Chessboard	392
FALSTAFF	Wallcovering	262
FARNESE	Fabric	328
FAUST	Wallcovering	257
FIGARO	Stool	49
FIGARO	Chair with armrests	59
FRISCO	Fabric	352
FUJI	Wallcovering	284
FUMO	Home basket	389
FUSION	Small bowls	404
GABRIEL	Multifunctional cabinet	172
GABY	Fabric	310
GALASSIA	Set of small tables	104
GARCIA	Mattress	140
GARDENIA	Bench	50
GARLAND	Mattress	141
GEM	Rug	234
GENT	Fabric	311
GENTIL	Vases	390
GIAVA	Mattress	140
GILDA	Table lamp	211
GINGER	Bowls	391
GINNY	Rug	234
GINZA	Wallcovering	278
GIO	Bedside table	120
GION	Wallcovering	279
GIOTTO	Chair without armrests	68
GLAM	Stool	50
GLAM	Coiffeuse	180
GLORIA	Glassware	400
GLOW	Table lamp	212
GOCCIA	Containers	389

RANGE	CATEGORY	PAGE
GOMEZ	Glassware	400
GRUMELLO	Fabric	328
HACK	Table lamp	212
HACK	Small lantern	386
HANOVER	Fabric	352
HAVANA	Fabric	317
HERO	Domino	392
HIDALGO	Bathroom set	384
HIMALAYA METALLIZED	Wallcovering	282
HIMALAYA RAFFIA	Wallcovering	286
HIROMI	Trays and accessories	391
HOLA	Candle	386
HOLA	Home fragrances	387
HOLLY	Frames	388
HONG KONG	Fabric	353
HOPE	Wall light	222
HUNTER	Globe	394
HYADES	Table lamp	213
IOLANTA	Wallcovering	260
JACKSON	Fabric	329
JAEN	Rug	235
JAIPUR	Fabric	329
JANETTE	Decorative cushion	408
JAPAN	Decorative cushion	408
JASPER	Desk set	394
JAVA	Wallcovering	284
JINGO	Round dining table	87
JINGO	Coffee table	103
JOE	Games	392
JOLANDA	Floor lamp	198
JOLANDA	Table lamp	213
JOLIE	Desk	147
JULIE	Armchair	38
JUSO	Fabric	330
JYLIA	Chair with armrests	61
KENSINGTON	Wallcovering	281
LAFAYETTE	Fabric	348
LANGSA	Fabric	331
LARRY	Small table	106
LARRY	Bedside table	121
LAUREN	Cutlery	399
LAURO	Service trays	391
LAWRENCE	Footrests	51
LEA	Chair with armrests	62

RANGE	CATEGORY	PAGE
LINK	Coffee tables	105
LIPARI	Wallcovering	291
LOGO	Table lamp in limited edition	16
LOGO	Table lamp	214
LOGO MINI	Lanterns	220
LOHENGRIN	Wallcovering	260
LONDON	Sofa	21
LONDON	Armchair and footrest	38
LORD	Glassware	400
LORELEY	Wallcovering	267
LOUIS	Dinnerware	399
LOUIS	Tea/Coffee set	403
LOULOU	Glassware	400
LOUVRE	Wallcovering	272
LUXEMBOURG	Fabric	318
LYON	Fabric	318
MACBETH	Wallcovering	255
MADDALENA	Chair with armrests	63
MADELEINE	Wallcovering	272
MAJORCA	Fabric	353
MALIN	Desk set	394
MANHATTAN	Console	94
MARAIS	Wallcovering	276
MARGOT	Armchair and footrest	39
MARSEILLE	Fabric	354
MARTIN	Bed	132
MASON	Rug	235
MATRIX	Set of consoles	95
MAX	Rug	236
MELROSE	Round dining table	88
MELROSE	Set of coffee table	107
MENEO	Bedside table	121
MERCI	Candles	386
MILES	Rug	236
MILTON	Bedside table	122
MIRÒ	Multifunctional cabinet	173
MISTRAL	Home baskets	389
MIYA	Floor lamp	198
MIYA	Table lamp and lantern	215
MONTE CARLO	Fabric	354
MONTMARTRE	Wallcovering	273
MOON	Spinning tops	392
MORFEO	Bed	134
MORGAN	Rug	237

RANGE	CATEGORY	PAGE
MOVE	Vases	390
MURANO	Wallcovering	292
MUSA	Bookcase	164
NABUCCO	Wallcovering (vertical)	254
NABUCCO	Wallcovering (horizontal)	259
NAGANO	Fabric	340
NAIKE	Chopsticks	404
NANJING	Fabric	341
NANJING	Decorative cushions	408
NARDO	Puzzle	392
NASTRO	Boxes	384
NATHALIE	Chair with armrests	63
NATHAN	Rectangular dining table	80
NED	Round dining table	89
NELLY	Lanterns	220
NELSON	Rectangular dining table	78
NEMA	Floor lamp	199
NEMO	Rack	182
NET	Small table	107
NEXT	Floor lamp	199
NEXT	Table lamp	214
NIAGARA	Wallcovering	288
NICE	Fabric	319
NIGHT	Floor lamp	201
NIGHT	Table lamp	216
NÎMES	Fabric	319
NINFEA	Coffee tables	108
NOIR	Rug	237
NOLA	Fabric	331
NOONA	Rug	238
NORBERT	Rack	182
NORFOLK	Fabric	332
NORIGAMI	Coffee tables	109
NORIKO	Table lamp	216
NOTO	Fabric	332
NOVA	Rug	238
OBELISC	Tea/Coffee set	403
OBERON	Wallcovering	258
OBI	Rug	240
OCTOBER	Dinnerware	399
ODE	Dinnerware	399
OFFSET	Set of consoles	99
OHIO	Fabric	355
OKINAWA	Fabric	333

RANGE	CATEGORY	PAGE
OKURA	Sushi set	404
OLATZ	Glassware	400
OLBIA	Fabric	320
OLIMPIA	Bookcase	165
OLIVIA	Desk	148
OMAGE	Chair without armrests	69
OMAR	Ashtray	390
OMBRA	Screen	186
ONDA	Chaise-longue	47
ONEIROS	Memory card game	392
ONORIO	Glassware	401
ONYX	Bookcases	164
OPEN	Modular system	32
OPERA	Wall light	223
OPÉRA	Wallcovering	273
ORCHESTRA	Rug	240
OREGON	Table lamp	217
ORENGO	Coasters	404
ORESTE	Small table	110
ORIANA	Vases	390
ORIENTE	Rug	241
ORIS	Bed	133
ORIZZONTE	Console	96
ORLANDO	Fabric	320
ORNELLA	Table lamp	217
ORSINI	Glassware	400
ORSON	Modular system	34
ORTENSIA	Placemat and napkins	406
ORWELL	Desk set	394
OSIMO	Sofa	22
OSLO	Fabric	321
OSTRA	Fabric	355
OTTAWA	Small table	108
OTTO	Chair without armrests	68
OULU	Fabric	321
OZ	Lanterns	221
OZZY	Plaid	410
PABLO	Rug	241
PACIFIC	Knives and other accessories	399
PAGE	Rectangular dining table	81
PALADINO	Table lamp	218
PALERMO	Fabric	322
PAMELA	Floor lamp	201
PAMELA	Table lamp	218

RANGE	CATEGORY	PAGE
PANAMA	Fabric	322
PANAREA	Wallcovering	292
PANTELLERIA	Wallcovering	293
PANTELLERIA	Wallcovering	395
PANTHEON	Wallcovering	274
PARADE	Rug	242
PARIS	Small table	111
PARMA	Fabric	304
PARSIFAL	Vases	390
PASCAL	Armchair	39
PASSION	Coiffeuse and stool	181
PAUL	Armchair	40
PEACOAT	Home baskets	389
PECHINO	Fabric	334
PEGASO	Scented candles	386
PEGGY	Chair with armrests	64
PENNY	Plaid	410
PERUGIA	Fabric	311
PETTY	Bath towels	411
PHILADELPHIA	Fabric	356
PHILOSOPHER	Rug	245
PHOEBE	Plaid	410
PIACENZA	Fabric	356
PICNIC	Lanterns	221
PILLAR	Rectangular dining table	82
PIPER	Shoes accessories	393
PISA	Fabric	312
PIUMA	Home baskets	389
PLAGE	Ping pong & Beach tennis	396
PLANET	Round dining table	90
PLANK	Coffee table	111
PLAY	Coffee/Side tables	112
PONZA	Wallcovering	294
PORTER	Bedside table	122
PORTER	Chest of drawers	169
PORTLAND	Fabric	341
PORTO	Fabric	343
PORTOFINO	Fabric	323
PRESTIGE	Multifunctional cabinet	174
PRETTY	Chaise-longue	48
PRISMA	Chair without armrests	70
PROTEA	Placemat	406
PUMP	Home fitness	396
PURFLE	Rug	242

RANGE	CATEGORY	PAGE
PURO	Side table	115
RAFFAELLO	Box	384
RAFFAELLO	Frame	388
RAIN	Plaid	410
RAMAGE	Floor lamp	202
RAPHAEL	Sofa	23
RAPHAEL	Armchair	40
RASHOMON	Mats	248
RASPBERRY	Placemat	406
RAVENNA	Fabric	344
RAVENSBURG	Fabric	305
REA	Floor lamp	204
REA	Wall Light	223
REALE	Fan	393
REAME	Rug	246
REBECCA	Set of napkins	406
REBEL	Rug	245
RECANATI	Fabric	344
REGNI	Chess / Plaid	392
REIMS	Fabric	312
REMBRANDT	Sofa	24
REMO	Glassware	401
REMY	Bench and stools/Side tables	52
RENOIR	Sofa	25
REST	Mug	403
RETTA	Floor lamp	205
RIDGE	Mats	248
RIESLING	Bar cabinet	162
RIGA	Fabric	305
RIGOLETTO	Wallcovering	270
RIMA	Chair with armrests	65
RIMA	Chair without armrests	71
RIVIERE	Bottle in Murano glass	401
RIVOLI	Fabric	335
ROBERTA	Placemat	406
ROBESPIERRE	Aprons	397
ROBESPIERRE	Barbecue set	397
ROBINSON	Sofa	26
ROCHA	Candle and tealight holders	386
RODEO	Footrests/Stools	53
ROGER	Kitchen accessories	405
ROLAND	Bed	136
ROLF	Glass snowball	387
ROMA	Bed	137

RANGE	CATEGORY	PAGE
ROMEO	Tray	391
RONDÒ	Armchair	41
RONIN	Screen	187
RONNIE	Table lamp	219
ROSANNA	Armchair in limited edition	15
ROSEMARY	Cocktail napkins and coasters	406
ROSEMUND	Rectangular dining table	83
ROSLIN	Chair without armrests	72
ROSSELLA	Towels	411
ROSTOV	Fabric	336
ROUEN	Fabric	306
ROUSSEAU	Desk	151
ROVO	Gardening set	397
ROWAN	Food and drink containers	397
ROXY	Stool	55
ROY	Mats	249
ROYAL	Cabinet bar in limited edition	13
RUBIK	Lanterns	219
RUDOLPH	Lap tray	405
RUFOUS	Tray	391
RUGIADA	Set for drinks/Cocktails	404
RUSSEL	Bedside table	124
RYO	Bedside table	123
RYOKO	Bed	138
SACHIKO	Plaid	410
SAETTA	Croquet set	392
SAGANO	Wallcovering	286
SAINT GERMAIN	Wallcovering	277
SAINT MORITZ	Fabric	337
SALINA	Fabric	358
SALISBURGO	Fabric	309
SALLY	Travel cushions	393
SALOME	Decorative cushion	409
SALOMÉ	Wallcovering	261
SAMBUCO	Mountain accessories	397
SAMSARA	Sea marbles	392
SAN FRANCISCO	Coffee tables	116
SANTIAGO	Fabric	325
SANTIAGO	Decorative cushion	409
SANZIO	Painter's tools	394
SANZIO	Painter's tools	397
SAO PAULO	Fabric	325
SAO PAULO	Decorative cushion	408
SAPPORO	Decorative cushion	409

RANGE	CATEGORY	PAGE
SARA	Placemat	406
SARAGOZZA	Decorative cushion	409
SATURNIA	Decorative cushion	409
SCARLETT	Blanket bag	393
SEA	Lantern	386
SECRET	Bathroom set	384
SEINE	Set of consoles	97
SELENE	Frame	388
SELMA	Decorative cushion	409
SELMA	Plaid	410
SEOUL	Decorative cushion	408
SESAMO	Screen	188
SEVEN	Magazine rack	183
SFINGE	Frames	388
SHANGHAI	Decorative cushion	408
SHARON	Armchair and footrest	43
SHIRLEY	Decorative cushion	409
SHIRLEY	Plaid	410
SHOW	Cloches	405
SIBILLA	Lanterns	222
SIDE	Screen	189
SIENA	Fabric	313
SIENNA	Decorative cushion	409
SIENNA	Plaid	410
SIGNATURE	Valet tray	394
SILVIA	Home baskets	389
SINGAPORE	Fabric	345
SIR	Backgammon	392
SIRACUSA	Fabric	309
SIRENA	Box	384
SIRENA	Ashtray	390
SIRIO	Box	384
SIRMIONE	Decorative cushion	409
SIVIGLIA	Fabric	326
SKIN	Fly-swatter and mosquito coil holder	397
SKY	Christmas decorations	387
SMART	Console	98
SMART	Chest of drawers	170
SMERALDA	Travel pouch	393
SNOW	Sledge	397
SOAVE	Christmas decorations	387
SOMEONE	Frames	388
SORAYA	Plaid	410
SPACE	Rectangular dining table	84

RANGE	CATEGORY	PAGE
SPIN	Yo-yo	392
SPRING	Spoons and cocktail sticks	405
STENDHAL	Desk	152
STOCKHOLM	Fabric	326
STRESA	Decorative cushion	409
STROMBOLI	Wallcovering	296
SUITE	Multifunctional cabinet	176
SUMATRA	Wallcovering	287
SUNNY	Lanterns	386
SURABAYA	Fabric	339
SUVA	Fabric	347
SUVA	Decorative cushion	409
SVEVA	Decorative cushion	409
SWEET	Side plate	405
TAO	Rack	184
TEORIA	Boxes	384
TERSILLA	Floor lamp	206
TOKYO	Armchair	41
TOMMY	Small tables	116
TOSCA	Wallcovering	254
TOWADA FIL	Wallcovering	288
TOWADA METALLIZED	Wallcovering	282
TROCADERO	Rectangular dining table	85
TROCADERO	Wallcovering	274
TURANDOT	Wallcovering	269
TUTANKHAMON	Rug	246
VENERE	Cutlery	399
VERSAILLES	Wallcovering	275
VETIVER	Bathroom set	384
VIRGINIA	Bed linen	411

This General Catalogue is for internal use only. Any reproduction of images and texts is forbidden without the explicit consent of Giorgio Armani.

All colors and textures visible in the pictures - including furniture, rugs, wallcoverings, fabrics and finishes - may not correspond to the real products. Woods and stones in particular could present some slight variations depending on the production lot. This feature must be considered a distinctive trait of the natural material used. Please always refer to our showrooms and official dealers for more information.

GIORGIO ARMANI
VIA BORGONUOVO 11
20121 MILANO ITALY
WWW.ARMANI.COM/CASA

© 2021 GIORGIO ARMANI

The background features a series of overlapping, wavy bands in various shades of brown and beige. Each band is filled with a fine, dense texture of small, repeating geometric patterns, creating a complex, layered visual effect. The bands curve and flow across the frame, creating a sense of movement and depth.

ARMANICASA.COM