

zerodue

2022

COLLECTION

Frigerio

\_02

**Frigerio**

Frigerio continua il racconto delle sue collezioni tramite scatti fotografici realizzati in contesti d'autore, luoghi non convenzionali ed evocativi in armonia con l'anima dell'azienda. Realizzato nel 1981 da Oscar Niemeyer, celebre firma dell'architettura contemporanea, l'edificio ex sede delle Cartiere Burgo (TO) si è reso riconoscibile nel tempo per lo stile innovativo e l'estetica futuristica. L'intera struttura dispone di una pianta di tipo anulare ed è costituita da un tamburo centrale collegato tramite quattro

percorsi radiali ad un complesso esterno circolare che lo circonda nella sua interezza. Caratterizzata da questa particolare forma a disco, l'ex sede delle Cartiere Burgo si snoda con libertà in spazi ampi e luminosi che esaltano il design dei prodotti Frigerio. Un'elegante scenografia dove gli arredi sono volutamente rappresentati sullo sfondo di un'atmosfera astratta che permette un esercizio di immaginazione tra reale e illusorio, spazio e tempo, passato e futuro.



Frigerio continues the story of its collection through photographs taken in artistic contexts, unconventional and evocative places in harmony with the soul of the company. Designed in 1981 by Oscar Niemeyer, a famous name in the contemporary architecture, the former headquarters of Cartiere Burgo, in province of Turin, has become recognizable over time for its innovative style and futuristic aesthetics. The whole structure has a ring-shaped floor plan and it is composed by a central drum connected

by four radial paths to an external circular compound that surrounds it in its entirety. Featuring this peculiar disk shape, the former headquarters of Cartiere Burgo winds freely through large and bright spaces which enhance the design of the Frigerio products. An elegant setting where the furniture is deliberately represented against a backdrop of an abstract atmosphere that allows an exercise in imagination between real and illusory, space and time, past and future.

## " THE FLOW " COLLECTION

Quando si parla di Flow, di flusso, si vuole sottolineare come ogni collezione racconti una propria storia: "il tempo narrativo può essere anche ritardante, o ciclico, o immobile. In ogni caso il racconto è un'operazione sulla durata, un incantesimo che agisce sullo scorrere del tempo, contraendolo e dilatandolo." (Lezioni Americane, Italo Calvino).

La nuova collezione Frigerio si caratterizza per lo stile senza tempo e la versatilità delle proposte. L'intuizione di collaborare con designer diversi specializzati nella lavorazione di materiali differenti e con molteplici visioni creative, ha infatti portato alla realizzazione di un'ampia collezione in cui ogni arredo entra in sinergia con gli altri dialogando in armonia. Il tempo inteso come un fluire di attimi, un continuo alternarsi di opposti che si contrastano senza contraddirsi, è il filo conduttore per descrivere la collezione Frigerio 2022.

"The Flow" Collection si presenta come un incontro, a prima vista inaspettato, di idee diverse ciascuna legata al proprio tempo e al proprio ritmo, in grado di raccontare una storia che si inserisce in un unico racconto sull'abitare contemporaneo all'insegna del colore e della leggerezza.

When we speak of "Flow", we want to highlight the fact that each collection tells its own story: "the narrative time can also be delaying, or cyclical, or immobile. In any case the story is an operation on duration, a spell performed on the flow of the time, contracting and dilating it." (Lezioni Americane, Italo Calvino).

The new Frigerio collection features a timeless style and a full versatility of the proposals. The intuition of collaborating with different designers specialized in working with different materials and with multiple creative visions, has in fact led to the creation of a large collection in which each piece of furniture enters into synergy with the others by dialoguing in harmony. Time understood as a flow of moments, a continuous alternation of opposites which contrast without contradicting each other, is the leitmotif to describe the Frigerio 2022 collection.

"The Flow" Collection is presented as an encounter, unexpected at first sight, of different ideas, each tied to its own time and rhythm, capable of telling a story, which fits into a single tale of contemporary living under the sign of colour and lightness.



FERRUCCIO LAVIANI



OSCAR  
E GABRIELE BURATTI



FEDERICA BIASI



FRONT



RICCARDO FRIGERIO

] INDEX



VIEW SOFA 09  
FERRUCCIO LAVIANI



ANDOREA SMALL TABLE 45  
RICCARDO FRIGERIO



HULI BENCH / STOOL 49  
FEDERICA BIASI



MAYU ARMCHAIR 31  
FRONT



HELIX POUF 35  
FRONT



CECILE ARMCHAIR 53  
FEDERICA BIASI



MOCKI SMALL TABLE 57  
FEDERICA BIASI



ELLY TABLE 37  
OSCAR E GABRIELE BURATTI



HUG CHAIR 43  
OSCAR E GABRIELE BURATTI



]**VIEW** SOFA  
DESIGN BY **FERRUCCIO LAVIANI**

Ferruccio Laviani collabora per la prima volta con Frigerio proponendo un divano modulare a terra, sintesi perfetta dell'estro creativo del designer e del know how decennale dell'azienda nel settore degli imbottiti. View rappresenta l'incontro tra estetica e funzionalità, un progetto ambizioso che trae nella complessità la sua forza distintiva. Emblema della capacità sartoriale di Frigerio, View si compone di moduli diversi combinabili tra loro con disinvoltura: la base del divano, in legno, laccata lucida o imbottita, dialoga con l'importante numero di elementi alcuni dall'animo classico altri dal design più originale che a loro volta si uniscono a schienali di diversa forma e dimensione e a braccioli anch'essi altamente personalizzabili.

Ferruccio Laviani collaborates for the first time with Frigerio by proposing a floor-standing modular sofa, a perfect synthesis of the designer's creative flair and the company's decades of know-how in the upholstered furniture branch. View represents the encounter between aesthetic and functionality, an ambitious project that draws its distinctive strength from its complexity. Emblem of the Frigerio's tailoring ability, View is composed by different modules which can be combined with ease: the base of the sofa, in wood, glossy lacquered or padded, dialogues with a large number of elements, some of which having a classical feel other with a more original design, which in turn are combined with backrests of different shapes and dimensions and armrests which are also highly customizable.

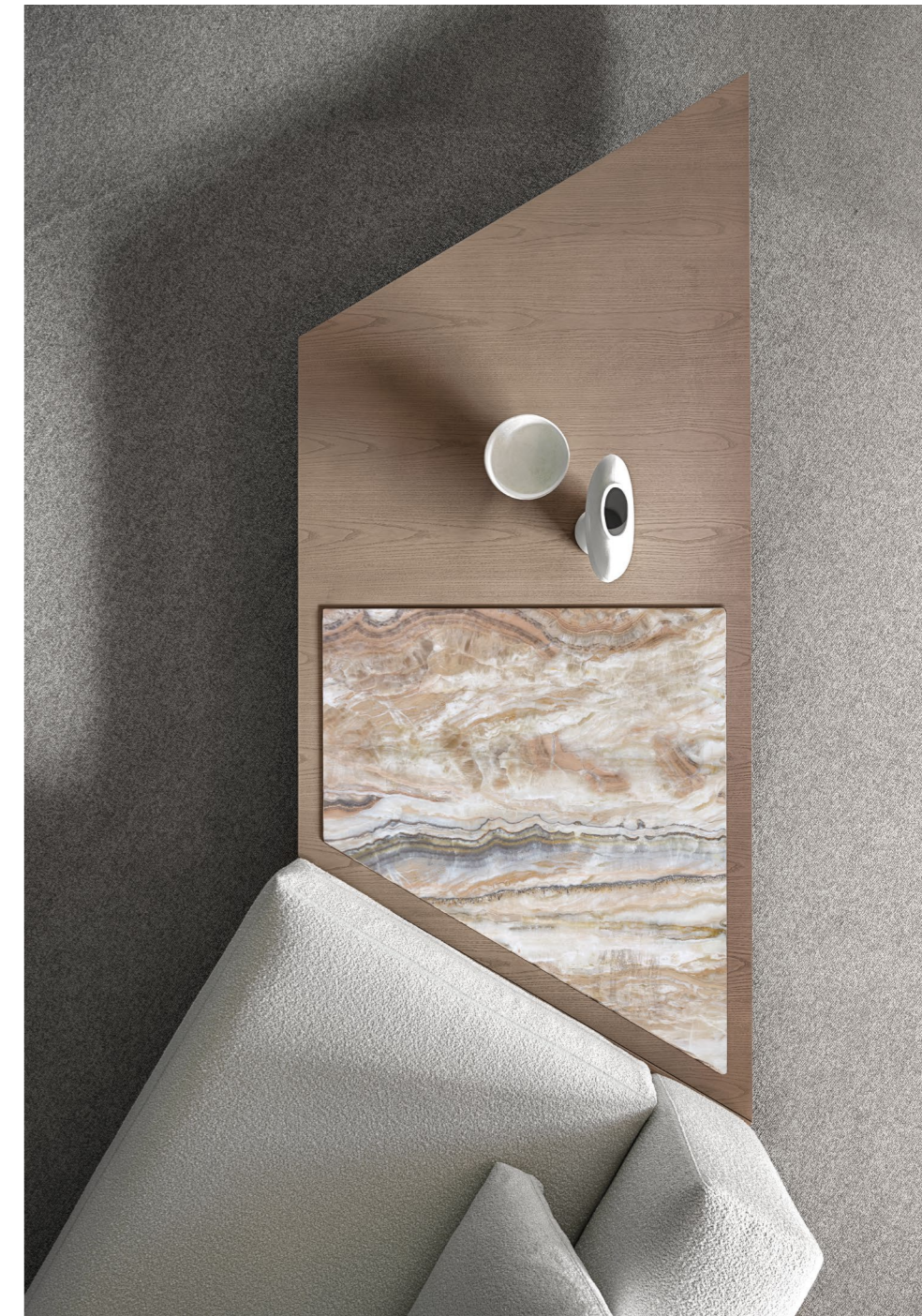



Come un astuto rompicapo, View svela il suo carattere di dettaglio in dettaglio, un vero e proprio gioco geometrico in grado di assumere diverse identità, dalla più convenzionale alla più estroversa, senza snaturarsi, facendo del cambiamento continuo l'essenza del suo arredare.

Like a clever riddle, View unveils its character from detail to detail, a true geometrical play capable of assuming different identities, from the most conventional to the most extrovert one, without misinterpretation, making the continuous change the essence of its furnishings.



2022 COLLECTION **VIEW** DESIGN BY FERRUCCIO LAVIANI







Con View il divano diventa spazio multifunzione.  
 Al comfort dei volumi imbottiti sono integrati  
 piani di appoggio, mensole, contenitori a giorno  
 per un sistema altamente personalizzabile.

With View the sofa becomes a multifunctional space.  
 Supporting shelves and open containers  
 are integrated in the comfort of the padded volumes  
 for a highly customizable system.



2022 COLLECTION **VIEW** DESIGN BY FERRUCCIO LAVIANI





2022 COLLECTION **VIEW** DESIGN BY FERRUCCIO LAVIANI

Lo spazio multifunzione del divano View si integra ad elementi laccati dalle forme geometriche per un risultato di carattere e distintivo.

The multifunctional space of the sofa View is integrated by lacquered elements with geometric shapes for a characterful and distinctive result.







Con View si possono abbinare liberamente i vari elementi, il divano assume così molteplici personalità, assecondando gli spazi che lo accolgono e il carattere di chi lo abiterà.

With View sofa there is the possibility of freely combining the various elements, the sofa so takes on multiple personalities, supporting the spaces that welcome it and the character of those who will inhabit it.







Il divano View, qui in una forma esagonale, introduce un clima di libertà e indipendenza in ogni interno.

The View sofa, here in a hexagonal shape, introduces an atmosphere of freedom and independence to any interior.





] **MAYU** ARMCHAIR  
DESIGN BY FRONT

Lavorare la materia per trascenderne la forma.  
Il gusto contemporaneo di Front incontra  
per la prima volta l'abilità produttiva di Frigerio  
dando vita a due proposte dall'estetica sofisticata,  
costruite su un delicato equilibrio  
di volumi grazie a lavorazioni sartoriali:  
il pouf Helix e la bergère Mayu.  
La ricercatezza che contraddistingue il design  
di Sofia Lagerkvist e Anna Lindgren viene  
qui declinata sul piano dei materiali e sull'attenta  
confezione dei singoli elementi,  
curati in ogni dettaglio.

Working with material to transcend its form.  
The contemporary taste of Front meets  
for the first time the production capability of Frigerio  
giving life to two proposals with sophisticated  
aesthetics, built on a delicate balance of volumes  
thanks to the tailoring manufacturing:  
the Helix pouf and the Mayu bergère.  
The sophistication of Sofia Lagerkvist and Anna  
Lindgren's design is reflected here in terms  
of materials and the careful manufacturing  
of individual elements, which are carefully crafted  
to every single detail.

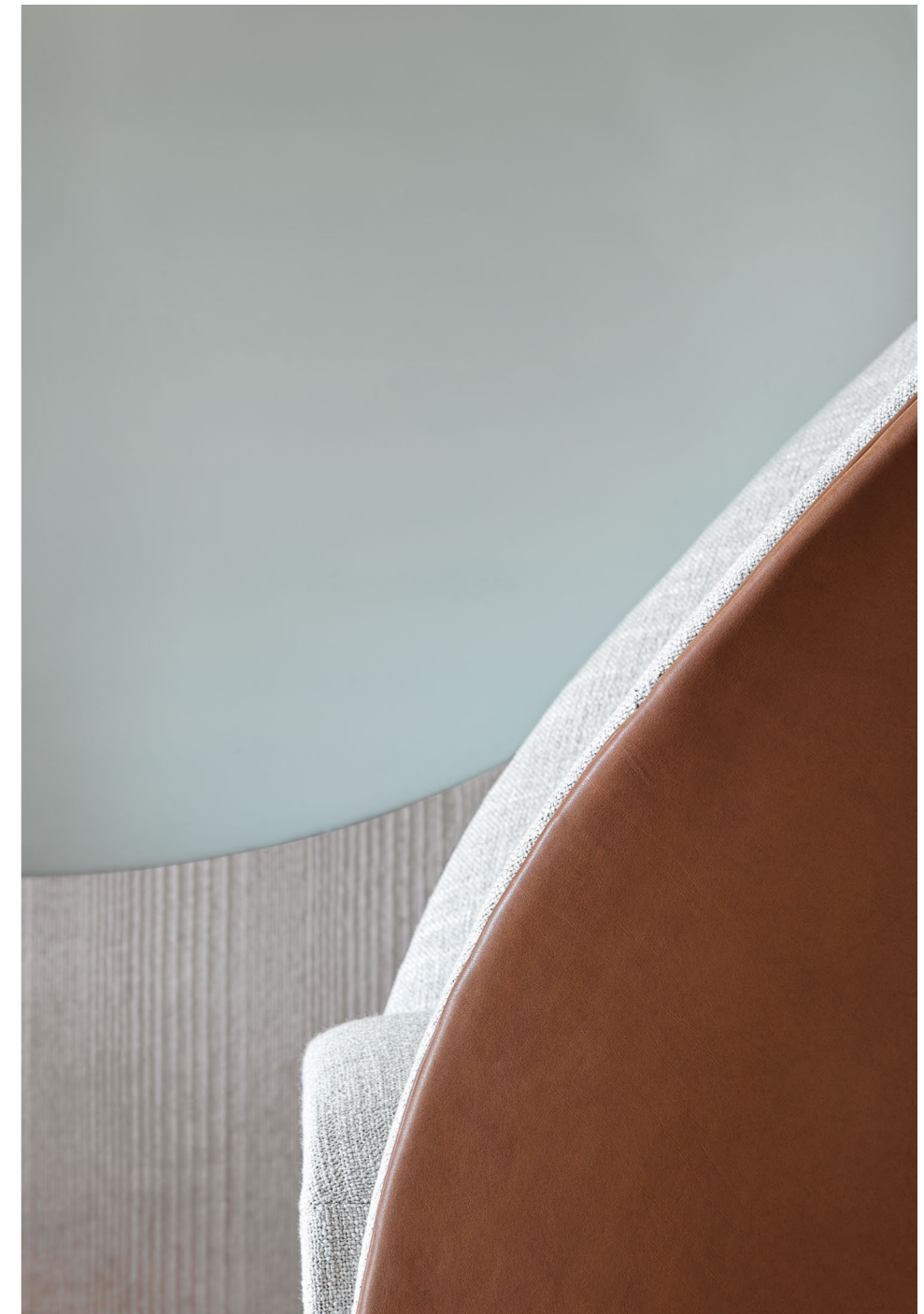

La bergère Mayu rappresenta il punto di arrivo di un lungo processo creativo e di produzione che ha portato alla realizzazione di uno stampo particolare che rispettasse l'idea creativa delle designer preservando la comodità e l'ergonomia della seduta.

The Mayu bergère represents the final point of a long creative and production process, which led to the creation of a peculiar mould which respects the creative idea of the designers, while preserving the comfort and the ergonomics of the armchair.





] **HELIX** POUF  
DESIGN BY FRONT

Helix è il risultato della maestria tecnica degli artigiani Frigerio che hanno tagliato e manipolato la pelle per darle la forma e l'aspetto di un foglio di carta, che si piega e incastra come in un origami.

Helix is the result of the technical mastery of the Frigerio artisans who cut and manipulated the leather to give it the shape and the appearance of a sheet of paper, which folds and fits like an origami.





ELLY TABLE  
DESIGN BY OSCAR E GABRIELE BURATTI

Il tavolo Elly si caratterizza per una struttura formata da colonne in legno fuse tra loro in un gioco di incastri che anima un progetto apparentemente semplice. L'ampia gamma di finiture disponibili sia per la versione rettangolare, che per quella tonda, permette al tavolo Elly di assumere estetiche diverse senza venir meno alla sua natura essenziale.

The table Elly features a structure formed by wooden columns fused together in a play of joints, which animates an apparently simple project. The wide range of available finishes for the rectangular and round versions, allows the Elly table to take on different aesthetics without sacrificing its essential nature.







2022 COLLECTION **ELLY** DESIGN BY OSCAR E GABRIELE BURATTI

L'essenza di questo tavolo risiede nella profonda ricerca sulla "complessa essenzialità" delle forme curvilinee e sul valore in termini di ricchezza volumetrica che ne scaturisce.

The essence of this table lies in the profound research on the "complex essentiality" of curvilinear forms and on the value in terms of volumetric richness that derives from it.



] **HUG** CHAIR  
DESIGN BY OSCAR E GABRIELE BURATTI

Ideale per l'ambiente domestico così come per gli spazi contract, Hug dialoga armoniosamente con il tavolo Elly con cui condivide l'estetica minimale ma incisiva: ironica e riconoscibile, la poltroncina abbraccia e avvolge grazie alla caratteristica struttura composta da schienale e bracciolo che incorniciano la seduta creando continuità tra ciascun elemento.

Ideal for residential environment as for contract spaces, Hug dialogues harmoniously with the Elly table, with which it shares the minimalist yet incisive aesthetic: ironic and recognizable, the small armchair embraces and envelops thanks to its peculiar structure composed of a backrest and armrest, which frame the seat by creating a continuity between each element.





] **ANDOREA** SMALL TABLE  
DESIGN BY RICCARDO FRIGERIO

Tratti orientali e dettagli distintivi.  
Riccardo Frigerio firma un tavolino in legno pensato per la zona giorno dalle forme geometriche e il design dinamico.  
Andorea si presenta come un elemento monolitico in legno che si caratterizza per la superficie irregolare che si erge in un punto creando una leggera curvatura che rivela la natura dinamica del prodotto.  
Proposta dal carattere contemporaneo, il tavolino Andorea racconta l'abilità dei maestri ebanisti di Frigerio, un arredo semplice che trova il suo tratto caratterizzante nei dettagli.

Oriental features and distinctive details.  
Riccardo Frigerio signs a wooden small table conceived for the day area with geometrical shapes and dynamic design. Andorea is featured as a monolithic wooden element characterized by an irregular surface that rises at one point by creating a slight curvature that reveals the dynamic nature of the product.  
A proposal with a contemporary character, the Andorea small table tells of the skill of the Frigerio's carpenters, a simple piece of furniture which finds its distinguishing feature in the details.





Con le sue linee armoniose, il tavolino Andorea si adatta ad ogni tipo di arredamento, donando un accento deciso e moderno allo spazio che lo circonda.

With its harmonious lines, the Andorea coffee table adapts to any type of furniture, giving a decisive and modern accent to the space that surrounds it.



2022 COLLECTION **ANDOREA** DESIGN BY RICCARDO FRIGERIO



] **HULI** BENCH / STOOL  
DESIGN BY **FEDERICA BIASI**

La forza del legno e l'utilizzo raffinato della corda. Federica Biasi consolida la collaborazione con Frigerio con nuove proposte e ampliamenti di gamma. A fronte del successo riscosso dalla lounge chair, si uniscono alla famiglia di complementi Huli lo sgabello e la panca che con le loro strutture curve si propongono come ampliamento di collezione, riprendendone l'intreccio caratteristico.

The strength of the wood and the refined use of the rope. Federica Biasi consolidates its collaboration with Frigerio with new proposals and by enlarging the range. Following the success obtained by the lounge chair, a stool and a bench are added to the Huli family, as an extension of the collection, with their curved structure by taking up the characteristic weave.







]**CECILE** SMALL ARMCHAIR  
DESIGN BY FEDERICA BIASI

La poltroncina Cecile è la nuova proposta firmata Biasi caratterizzata da una struttura in legno e una seduta intrecciata in corda di carta, o imbottita, che dona un tocco di eleganza disinvolta all'ambiente.

The Cecile small armchair is the new proposal signed by Biasi featuring a wooden structure and a woven paper cord seat, or upholstered seat, which gives a touch of casual elegance to the setting.



L'esile struttura a sezione tonda che sorregge seduta e schienale, rivela l'abile maestria nella lavorazione del legno.

The slender round section structure that supports the seat and back reveals the skillful mastery of processing wood.



] **MOCKI** SMALL TABLE  
DESIGN BY FEDERICA BIASI

Giochi materici e coincidenza di forme: il tavolino Mocki ha una struttura in legno su cui si appoggia il top, disponibile sia ovale che rotondo. Equilibrio di finiture e forma tondeggianti, il tavolino Mocki esprime l'idea di un living in grado di svelare la sua personalità in dettagli raffinati.

Game of materials and coincidence of shapes: the Mocki small table has a wooden structure on which the top rests, available both oval and round. Balance of finishes and rounded shape, the Mocki small table expresses the idea of a living room able to reveal its personality in refined details.





**VIEW SOFA** pag. 10

Ferruccio Laviani

Collezione di divani componibili con differenti basi combinabili fra loro, disponibili in versione imbottita, legno o laccata coordinate a differenti tipologie di braccioli. Completano la gamma volumi imbottiti integrati con piani in appoggio e mensole.

Collection of sectional sofas with different bases that be combined with each other, available with upholstered, wooden or lacquered version coordinate with different types of armrests. The collection is completed by padded volumes integrated with shelves and trays.



COMPOSITION 01 pag. 10

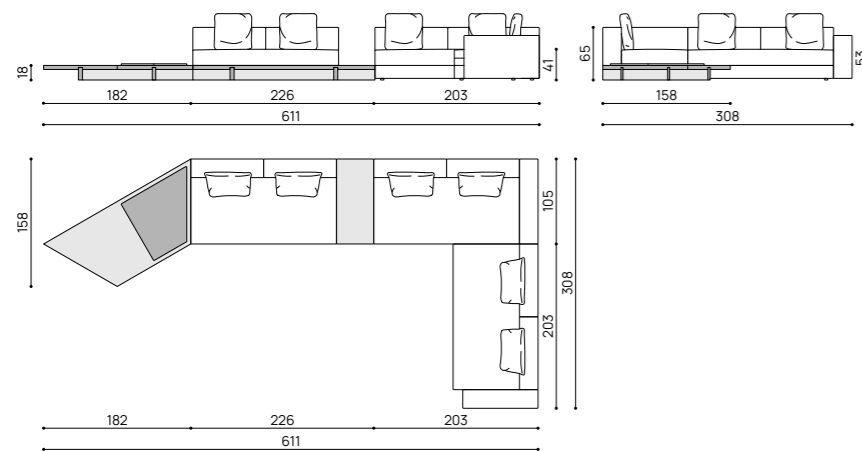

COMPOSITION 03 pag. 22

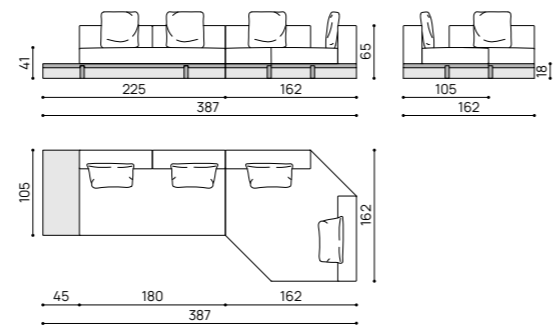

COMPOSITION 02 pag. 18

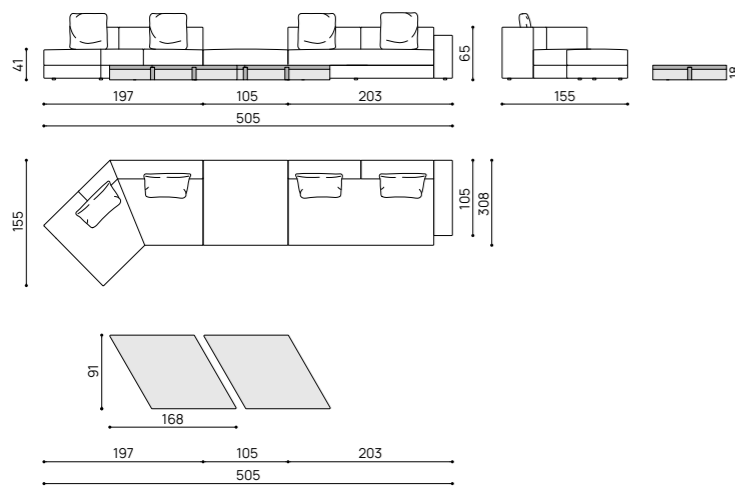

COMPOSITION 04 pag. 28

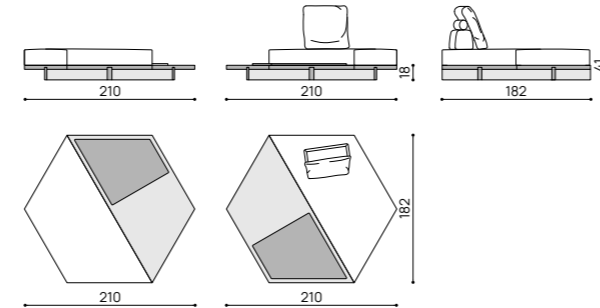

COMPOSITION 05 pag. 26

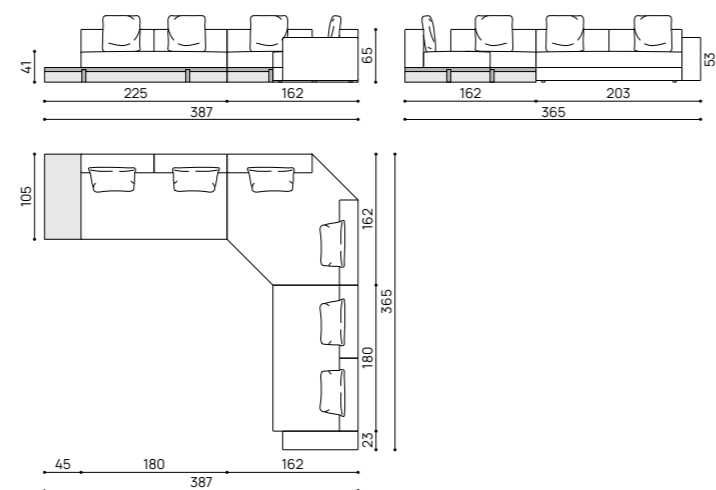

**MAYU ARMCHAIR** pag. 50

Front



Poltrona con struttura in monoscocca rivestita con poliuretano espanso in varie densità disponibile in tessuto o pelle o nella versione con schienale rivestito esternamente in pelle e internamente in tessuto.

Armchair with one-piece body covered with polyurethane foam in different densities available in fabric or leather or in the version with backrest covered externally in leather and internally in fabric.

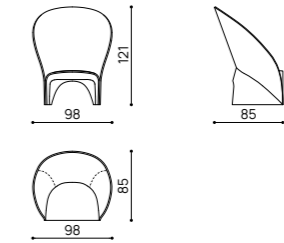

**HELIX POUF** pag. 38

Front



Pouf con basamento in noce canaletto o frassino nei colori Frigerio. Struttura rivestita in pelle con cuciture decorative e accoppiata a tessuto coordinato.

Pouf with base in Canaletto walnut or ashwood in the Frigerio colours. Structure covered in leather with decorative stitching and coupled with matching fabric.

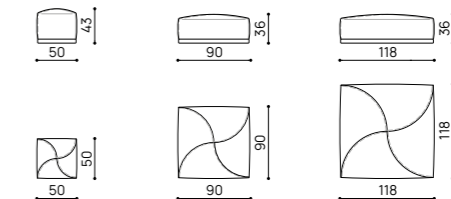

**ELLY TABLE** pag. 54

Oscar e Gabriele Buratti



Collezione di tavoli tondi o rettangolari disponibili nelle versioni completamente laccati nei nuovi colori della collezione Frigerio oppure con basamento in legno di frassino e top in marmo o legno.

Collection of round or rectangular tables available in a fully lacquered version in the colours of the Frigerio collection or with base in ashwood and top in wood coordinate with the base or marble.

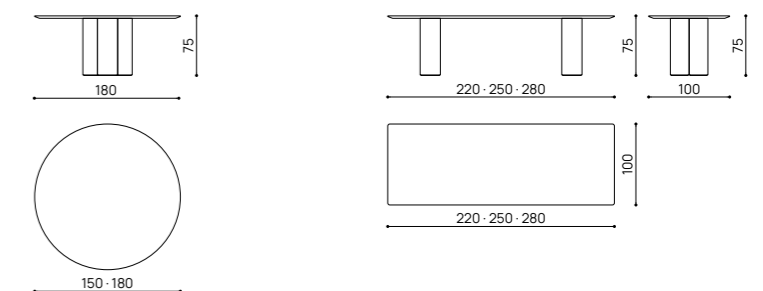



**HUG CHAIR pag. 32**

Oscar e Gabriele Buratti

Sedia con struttura in legno e poliuretano espanso rivestita in tessuto o pelle con gambe in metallo a sezione ovale.

Chair with wooden structure padded with polyurethane foam covered in fabric or leather with metal legs with oval section.

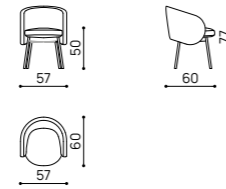

**CECILE SMALL ARMCHAIR pag. 46**

Federica Biasi

Poltroncina con struttura in legno massello di frassino con seduta disponibile in rattan o con seduta imbottita rivestita in tessuto o pelle.

Small armchair with solid ashwood structure with seat available in rattan or in padded version covered in fabric or leather.

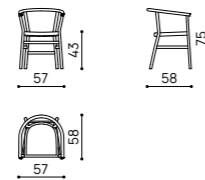

**HULI BENCH / STOOL pag. 42**

Federica Biasi

Panca e sgabello con struttura in legno massello e intreccio in corda.

Bench and stool with solid wood structure and braid rope.

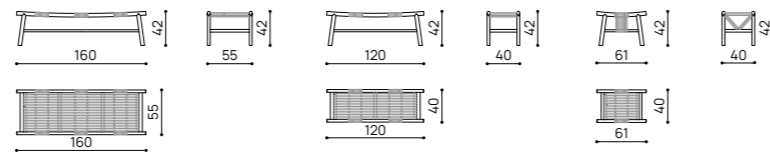

**MOCKI SMALL TABLE pag. 50**

Federica Biasi

Collezione di tavolini con basamento in legno in frassino con un top disponibile in ceramica, marmo o in legno coordinato alla struttura.

Collection of small tables with base in ashwood and top available in ceramic, marble or wood coordinated to the structure.

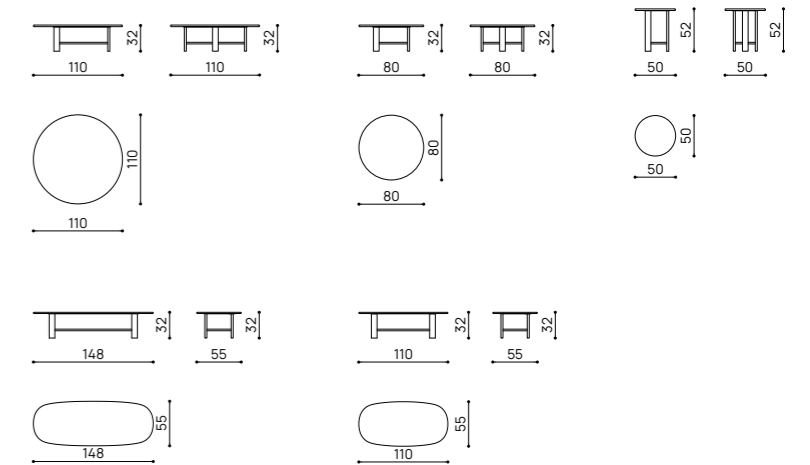

**ANDOREA SMALL TABLE pag. 38**

Riccardo Frigerio

Tavolini monoblocco quadrati o rettangolari in noce canaletto o frassino caratterizzati da una superficie irregolare con un'alzata dinamica ad uso poggialibri.

Monobloc small tables either square or rectangular in walnut Canaletto or ashwood featuring an irregular surface with a dynamic riser for use as bookrest.

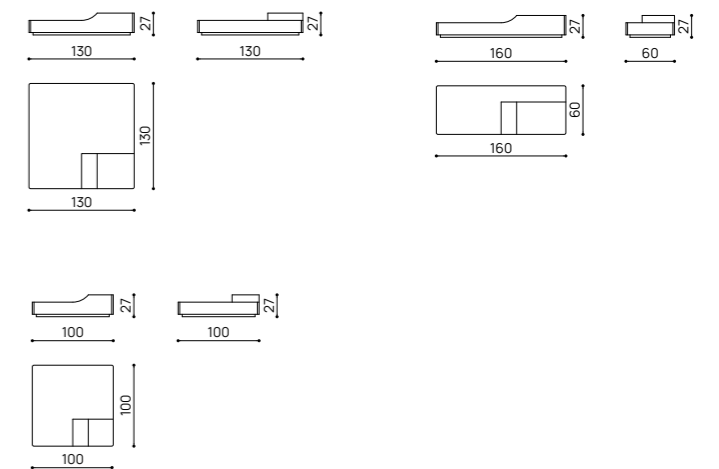

**Art Direction:**

R+W

**Graphic Project:**

Michela Boglietti

**Project Coordination:**

R&D Frigerio

**Photo:**

Location: Gionata Xerra Studio

Still-life: Studio Eleven

**Colour Separation :**

CD Cromo

**Photo Assistant location:**

Leonardo Duggento

**Postproduzione immagini location:**

Pierpaolo Mazzola

**Credits:**

Ex-Sede Cartiere Burgo

San Mauro Torinese

10099, Torino

# Frigerio

FRIGERIO POLTRONE E DIVANI

Via Sant'Agata, 63

Mariano Comense CO - Italy

T. +39 031 5481225

[www.frigeriosalotti.it](http://www.frigeriosalotti.it)

